

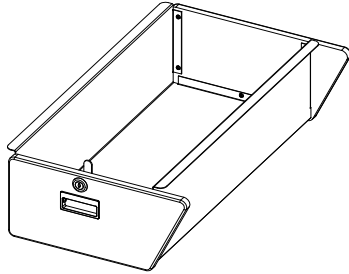

Your Performance Partner

Owner's and Assembly Manual teacherTAXI® Accessories



Drawer Accessory

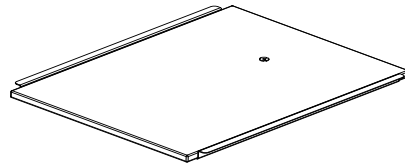

Worksurface Accessory

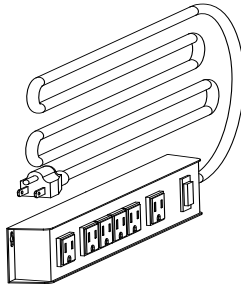

Power Strip Accessory

CONTENTS

Safety	2
Warranty	2
Important User Information	3
Installation	3
Intended Use	3
Parts List	4
Drawer Installation	5
Worksurface Installation	6
Power Strip Installation	7

Note: Please read and understand the teacherTAXI Accessory Owner's Manual before attempting installation, assembly, or use.

Note: Remove all items from the shipping containers and sort the components by type, size, etc. Refer to the illustrations on the following pages. If you need additional information about your teacherTAXI Accessory, contact the Wenger Corporation using the information listed below.

SAFETY

Throughout this manual you will find **Cautions** and **Warnings** which are defined as follows.

- **Warning** means that failure to follow the instruction may result in serious injury or death.
- **Caution** means that failure to follow the instruction may result in injury or damage to property.

Read and understand the following safety instructions before using or installing any teacherTAXI Accessory.

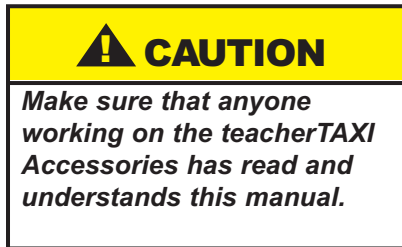

WARRANTY

The teacherTAXI Accessories is guaranteed free of defects in materials and workmanship for five full years.

Our guarantee assures you of either a full refund or repair or replacement of the defective materials or workmanship without charge, at the discretion of our Customer Service Department. Just call a Customer Service Representative at 1-800-887-7145 and state the reason you are dissatisfied. If a product return is necessary, your representative will issue a return authorization. This is your sole remedy for breach of this warranty.

Should you have a question or problem with any Wenger product, don't hesitate to call, even if the product is past warranty. It's important to us that all our customers be satisfied.

This is the sole warranty made by Wenger. Wenger disclaims all other warranties, including the warranties of merchantability and fitness for a particular purpose, as well as all liability for incidental, consequential, special, and indirect damage. Wenger liability for direct damages shall be limited to the amount you paid for the product involved. Wenger reserves the right to make product changes without obligation to incorporate such changes into products previously sold.

Some states do not allow the exclusion or limitation of damages or warranties, so the above may not apply to you. This warranty gives you specific legal rights. You may also have other rights which vary from state to state.

IMPORTANT USER INFORMATION

GENERAL

Copyright® 2009 by Wenger Corporation

All rights reserved. No part of the contents of this manual may be reproduced, copied, or transmitted in any form or by any means including graphic, electronic, or mechanical methods or photocopying, recording, or information storage and retrieval systems without the written permission of the publisher, unless it is for the purchaser's personal use.

Printed and bound in the United States of America.

The information in this manual is subject to change without notice and does not represent a commitment on the part of Wenger Corporation. Wenger Corporation does not assume any responsibility for any errors that may appear in this manual.

In no event will Wenger Corporation be liable for technical or editorial omissions made herein, nor for direct, indirect, special, incidental, or consequential damages resulting from the use or defect of this manual.

The information in this document is not intended to cover all possible conditions and situations that might occur. The end user must exercise caution and common sense when assembling or installing Wenger Corporation products. If any questions or problems arise, call Wenger Corporation at 1-800-733-0393.

MANUFACTURER

The teacherTAXI Accessories are manufactured by:

Wenger Corporation
555 Park Drive
Owatonna, MN 55060
1-507-455-4100 • 1-800-733-0393
www.wengercorp.com

INSTALLATION

- Personnel installing the teacherTAXI Accessories must comply with the Warnings and Cautions in the Safety Section.

INTENDED USE

- The teacherTAXI Accessories are intended for indoor use in normal ambient temperature and humidity conditions — it must not be exposed to prolonged outside weather conditions.

PARTS LIST

DRAWER ACCESSORY

<u>Item</u>	<u>Qty</u>	<u>Description</u>
1	1	Drawer
2	1	Drawer Mount Bracket
3	4	Self-tap Screws, #8 - 18 x 3/4

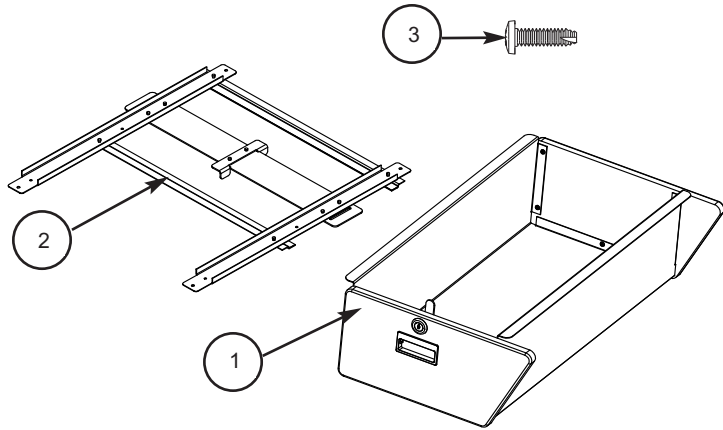

WORKSURFACE ACCESSORY

<u>Item</u>	<u>Qty</u>	<u>Description</u>
1	1	Worksurface
2	1	Worksurface Mount Bracket
3	4	Self-tap Screws, #8 - 18 x 3/4
4	1	Machine Screw, 1/4-20 x 1.25

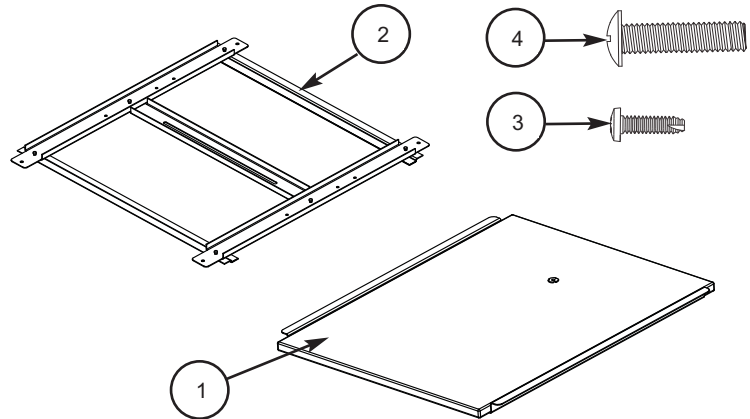

POWER STRIP ACCESSORY

<u>Item</u>	<u>Qty</u>	<u>Description</u>
1	1	Power Strip Accessory
2	1	Power Strip Mount

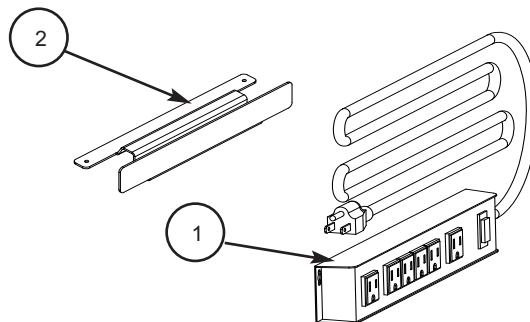

DRAWER INSTALLATION

1. Attach the Drawer Mount Bracket (#2) to the frame of the teacherTAXI

Note: Installing the Drawer Mount Bracket (#2) is easier if the teacherTAXI is placed upside down on a work table.

- a. Place the Drawer Mount Bracket (#2) under the top shelf of the teacherTAXI aligning the predrilled holes of the Drawer Mount Bracket (#2) and frame of the teacherTAXI.
- b. Attach the Drawer Mount Bracket using four self tap screws (#3). **(Detail A)**

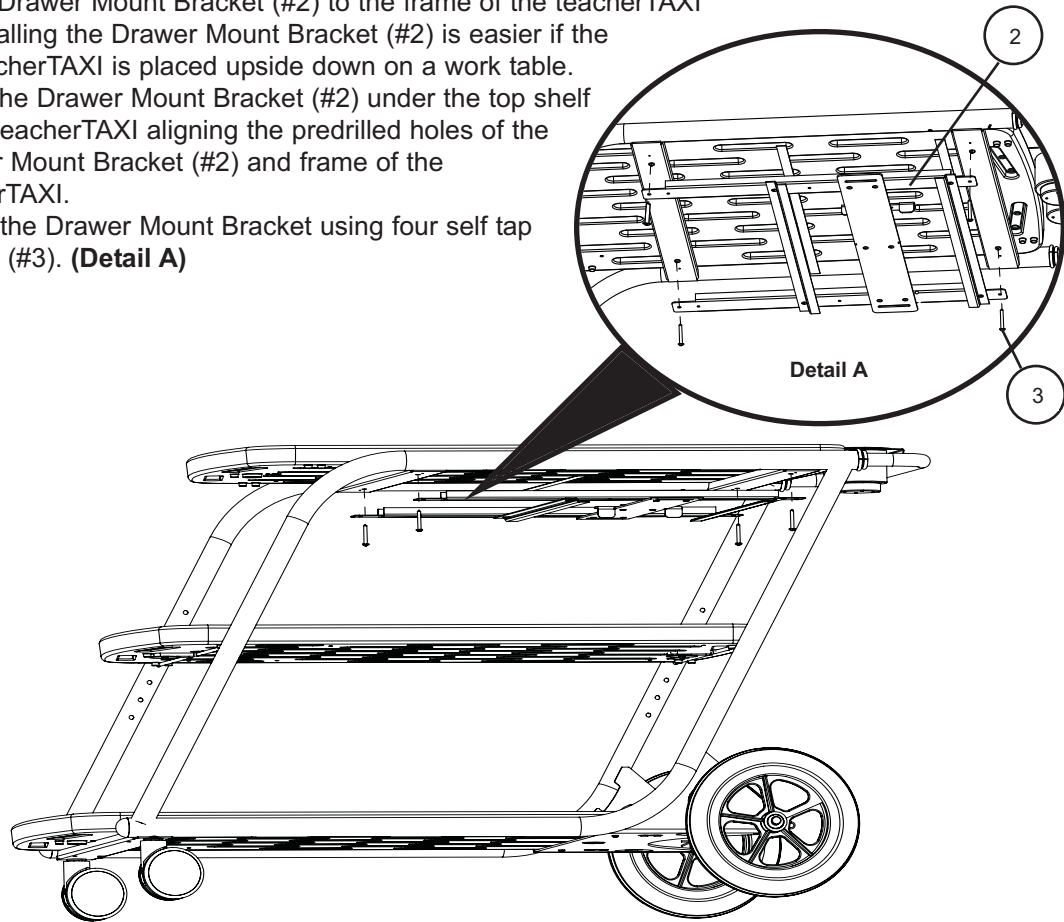

2. Slide the Drawer (#1) onto the Drawer Brackets (#2). Push up the Drawer Lock Bar to secure the drawer onto the Drawer Brackets. **(Detail B)**

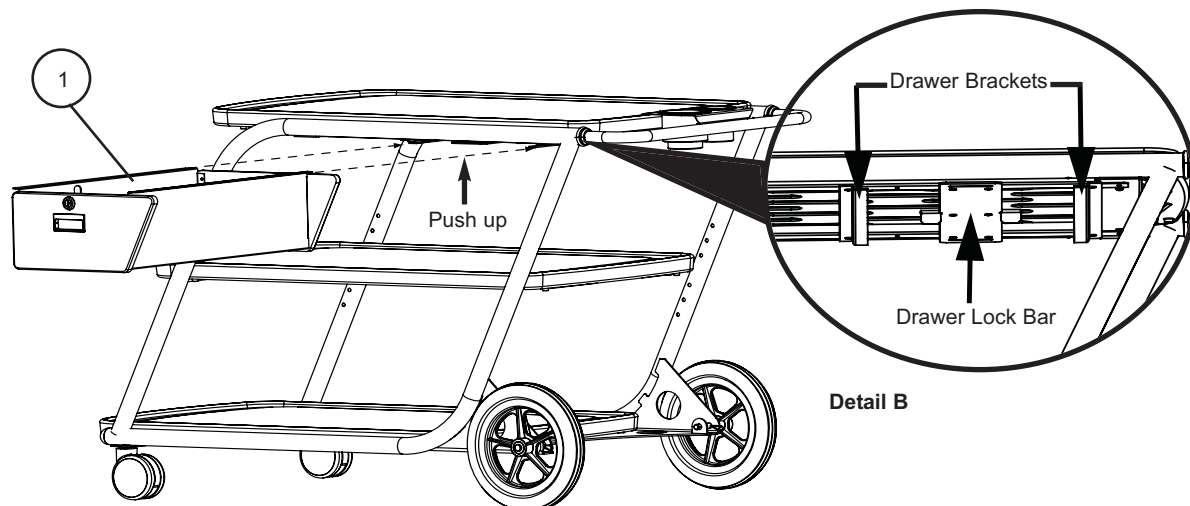

WORKSURFACE INSTALLATION

- 1 Attach the Worksurface Mount Bracket (#2) to the frame of the teacherTAXI.
Note: Installing the Worksurface Mount Bracket (#2) is easier if the teacherTAXI is placed upside down on a work table.
 - a. Place the Worksurface Mount Bracket (#2) under the top shelf of the teacherTAXI aligning the predrilled holes of the Worksurface Mount Bracket (#2) and frame of the teacherTAXI.
 - b. Attach the Worksurface Mount Bracket (#2) using four self tap screws (#3). **(Detail A)**

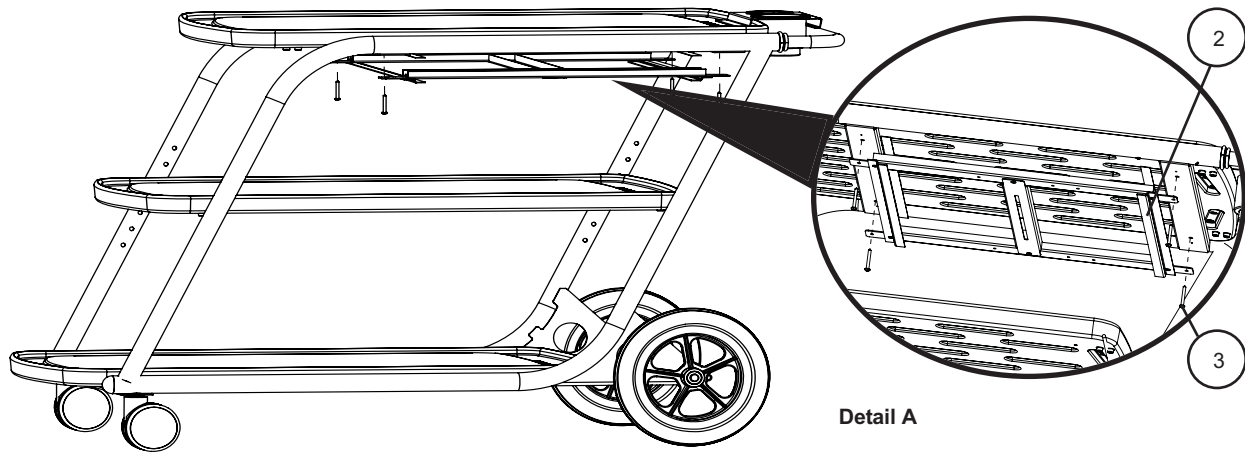

2. Slide the Worksurface (#1) onto the Worksurface Mount Bracket (#2) leaving 6" of the Worksurface sticking out of the bracket. **(Detail B)**
3. Secure the Worksurface (#1) to the Worksurface Mount Bracket (#2) using machine screw (#4). Make sure the screw is into the slot in the Mount Bracket. **(Detail C)**

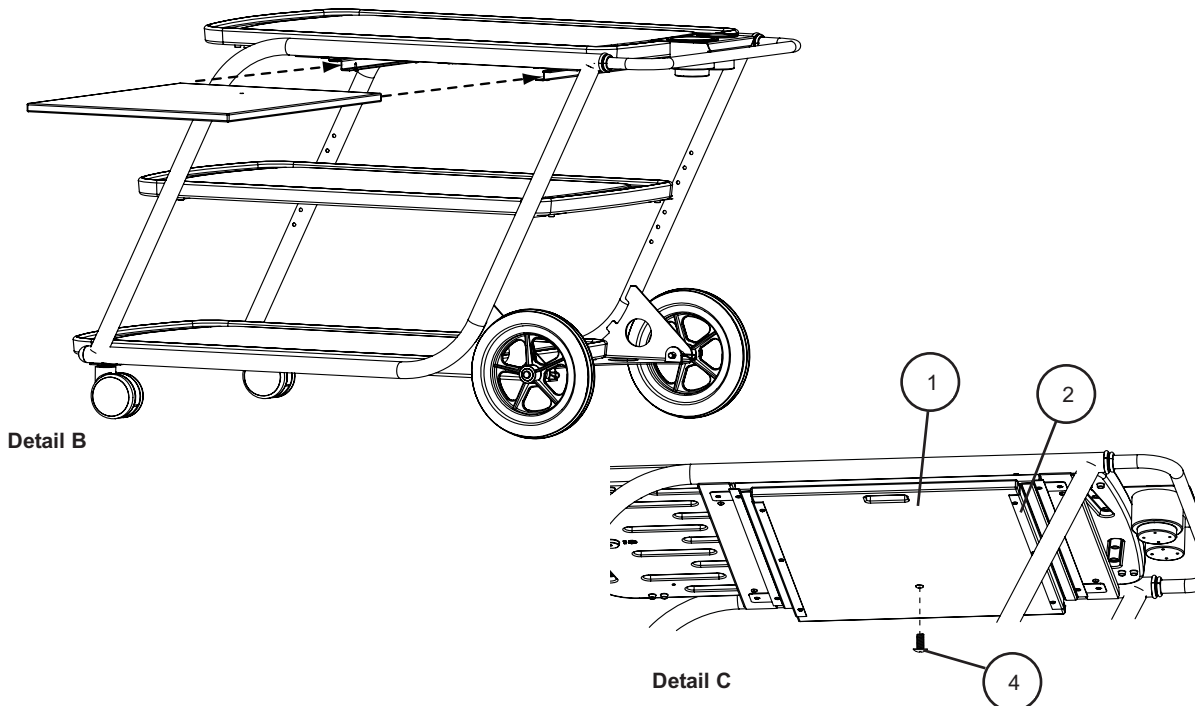

POWER STRIP INSTALLATION

1. Attach the Power Strip (#1) to the shelf of the teacherTAXI (**Detail A**)
 - a. Using the alcohol pad (provided), clean the surface.
 - b. Remove backing from foam tap on Power Strip Mount (#2) and place on shelf in desired location.
Note: Foam tape is difficult to remove once set. Be sure of location before pressing in place.
 - c. Clean Power Strip (#1) back.
 - d. Remove backing from foam tape and place Power Strip (#1) on Power Strip Mount (#2).

