



CONTENTS

Safety	2
General	2
Operation	2
Warranty	3
Important User Information	3
Operation	3
Intended Use	3
Hydrate Cart Usage	4
Maintenance	5
Cleaning and Sanitizing the Hydrate Cart	6
Replacement Parts List	7

NOTE: Please read and understand the Hydrate Cart Operating Instructions before attempting use.

SAFETY

Throughout this manual you will find **Cautions** and **Warnings** which are defined as follows.







- **Warning** means that failure to follow the instruction may result in serious injury or death.
- **Caution** means that failure to follow the instruction may result in injury or damage to property.

GENERAL

⚠ CAUTION	⚠ CAUTION	⚠ CAUTION
<p><i>Use of the Hydrate Cart must always comply with the information in the “Important End User Information, Intended Use” section on page 3 of this manual.</i></p>	<p><i>When using the Hydrate Cart, always observe and comply with Warnings and Cautions posted in this manual and on the Hydrate Cart.</i></p>	<p><i>Familiarize yourself with the manufacturers (Ascent™ and SHURflo®) data sheets attached to this manual.</i></p>

OPERATION

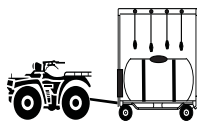
⚠ CAUTION

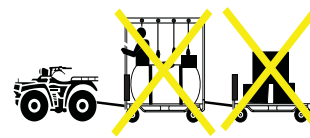
 <p>Read and understand the Operating Instructions before using this equipment.</p> <hr/> <p>Sanitation:</p>  <p>To ensure a sanitary system completely drain the Hydrate Cart after every use and maintain a sanitation schedule per the manual.</p> <hr/>  <p>When moving the Hydrate Cart up or down a hill it is recommended that a brakeable source (lawn tractor, Gator, etc.) be used.</p> <hr/>  <p>While the Hydrate Cart is intended for outdoor use, avoid long-term exposure to UV rays and extreme elements.</p>	 <p>Never move the Hydrate Cart at more than a normal walking speed.</p> <hr/>  <p>• Maximum speed of 10 mph when pulling Hydrate Cart with a motorized vehicle.</p> <ul style="list-style-type: none"> • It is recommended that the Hydrate Cart is towed by a utility type vehicle such as lawn tractor, Gator or 4-wheeler. • The Hydrate Cart is intended for towing over grass fields and pavement. <hr/>  <ul style="list-style-type: none"> • Always use at least two people to move the Hydrate Cart. • Fully loaded Hydrate Cart can exceed 650 lbs. Use caution when moving cart and ensure the cart is in control and stoppable. 	 <ul style="list-style-type: none"> • Never move or position the Hydrate Cart sideways on an incline over 10°. • Avoid sharp turns as the water in the Hydrate Cart is dynamic and creates a live load. <hr/>  <ul style="list-style-type: none"> • The Hydrate Cart is not intended for additional loads or passengers. • The Hydrate Cart is not intended to pull another vehicle.
---	--	--

WARRANTY

The limited warranty set forth below is given by Wenger Corporation with respect to the Hydrate Cart. Wenger Corp. warrants this product as defined below commencing on the date of original purchase.

- Full product warranty against defects in material and workmanship for a period of one (1) year.
- All aluminum welds are warranted for 5 years from purchase date.
- The tank is warranted for 3 years from purchase date.
- SHURflo® model 2088 pumps are covered by the manufacturer's warranty.
- Battery Tender battery charger is covered by the manufacturer, Deltran Corp. See manufacturer's warranty for details.

Wenger will, at its option, repair or replace, free of charge, any part found to be defective in material or workmanship.

This limited warranty shall only apply if this product has not been subject to misuse, abuse, neglect, accident, vandalism, theft, fire, water or damage because of peril or natural disaster. Damage resulting from the installation or use of any accessory or attachment not approved by Wenger for use with this product will void your warranty as to any resulting damage.

This limited warranty does not provide coverage in the following cases:

Wear items – Tires, wheel bearings, drain valves, shutoff valves, battery, electrical switches or tubing.

How to obtain service: Contact Wenger Corporation customer service at 800.887.7145

This is the sole warranty made by Wenger. Wenger disclaims all other warranties including the warranties of merchantability and fitness for a particular purpose, as well as liability for incidental, consequential, special and indirect damage. Wenger liability for direct damages shall be limited to the amount you paid for the product. Wenger Corp. reserves the right to change or improve the design of any product without assuming any obligation to modify any product previously manufactured.

IMPORTANT USER INFORMATION

OPERATION

- Personnel operating the Hydrate Cart must read and understand these instructions.
- Personnel operating the Hydrate Cart must comply with the Warnings and Cautions in these instructions.

INTENDED USE

- The Hydrate Cart is intended to deliver a large volume of water or hydrating fluid to athletes outdoors.
- The Hydrate Cart is intended to be able to be filled indoors and move through the facility and standard doorways.
- The Hydrate Cart is intended to be towed outside by a power source with a pin hitch not more than 10 mph.
- The Hydrate Cart is intended for towing over grass fields and pavement.

HYDRATE CART USAGE

1. Open the Hydrate Cart tank by unscrewing the top cover. Remove the battery charger and drinking tubes/nozzles located inside the tank (figure 1).
2. The battery is located on the front of the Hydrate Cart. Charge the battery by plugging the connector of the battery charger into the front of the battery (figure 2).
3. Attach the drinking tubes to the Hydrate Cart by firmly pushing the tubes into the couplers and tug down to make sure they are secure (figure 3).
4. Clean and sanitize the tank prior to use - see cleaning and sanitizing instructions on page 6 of this manual.
5. Verify that the drain valve is closed (figure 5).
6. Fill the Hydrate Cart with water or hydrating fluid (figure 6).
7. Turn on pump when in use. Be sure to turn off the pump when not in use (figure 7).
8. Before every use turn on pump, open and hold line for 5 seconds (figure 8).
9. Be sure to empty the Hydrate Cart after every use (figure 5).

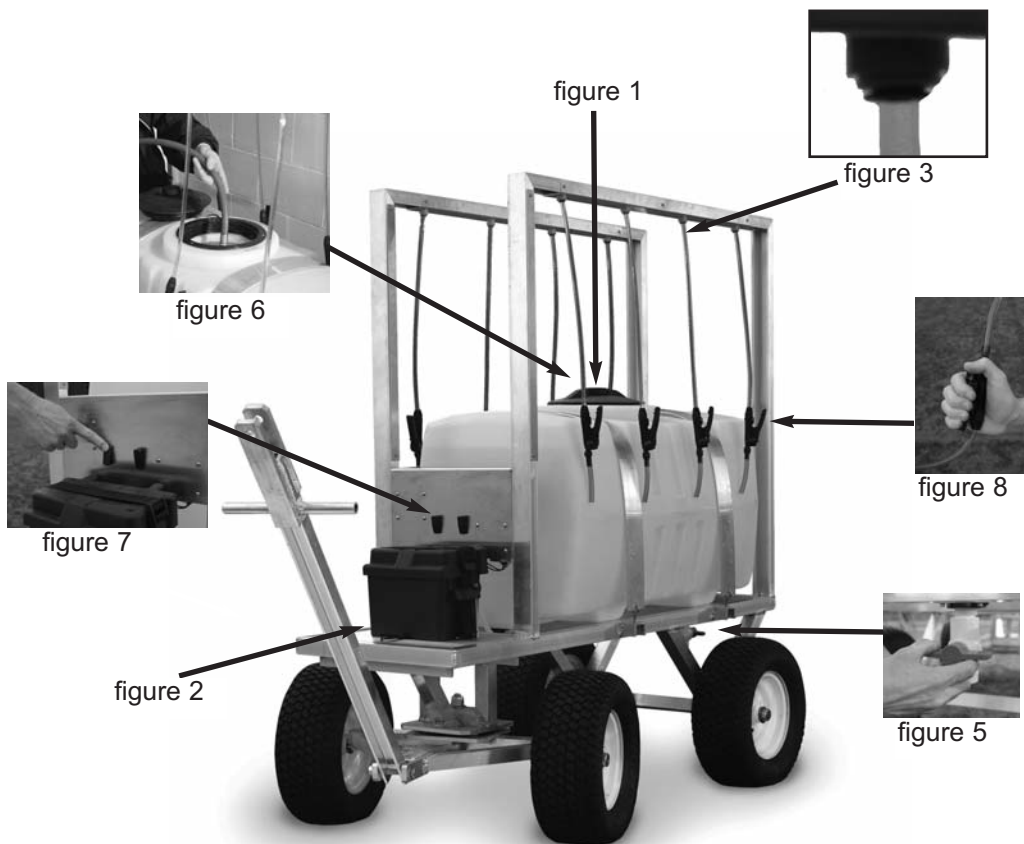

MAINTENANCE

- Keep tires inflated to maximum 28 psi.
- Every 30 days of use, check wheel collars for tightness.
- Once a year, check all fasteners for tightness.
- Once a year, apply grease to all grease zerks.
- When winterizing make sure the Hydrate Cart is fully drained of all liquids. A fully drained cart can be stored in freezing temperatures.
- Keep the battery charged. Lead-Acid type batteries do not have a memory, therefore they can be charged at any time. During storage, place on charger at least every 30 days to maintain battery life. Charge daily during heavy use periods. The charger is automatic and will shut off when battery is fully charged.
- Pumps are On-Demand type and will run constantly when tank is empty. Remember to turn off pumps when not in use or tank is drained.

Removal and replacement of drinking tubes/nozzles:

Connecting:

To make a connection, the tube is simply pushed in by hand. The unique patented John Guest collet locking system then holds the tube firmly in place without deforming it or restricting flow.

1. Push the tube into the fitting. The collet (gripper) has stainless steel teeth which hold the tube firmly in position while the 'O' ring provides a permanent leak proof seal.
2. Pull on the tube to check that it is secure. It is a good practice to test the system prior to leaving site and before use.

Disconnecting:

To disconnect, ensure the system is depressurized before removing the tube.

1. Push the collet squarely against face of fitting. With the collet held in this position, the tube can be removed.

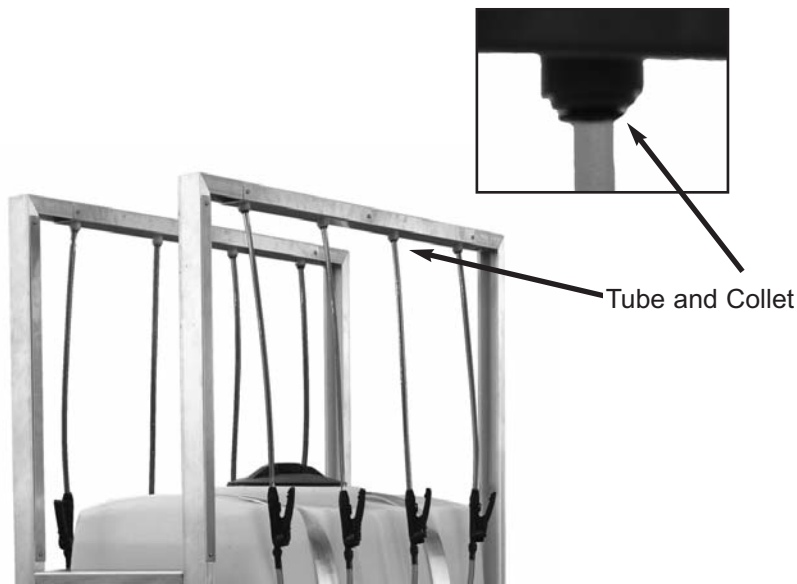

SANITIZING THE HYDRATE CART

After every use, fully drain Hydrate Cart .

1. Open the drain valve and drain the tank.
2. Turn on pumps and open every nozzle to expel water from the drinking tubes and pump.
3. Turn off the pumps.

Cleaning and sanitizing the Hydrate Cart

It is recommended that you clean the Hydrate Cart tank after every week's usage.

1. Fill the tank half-way with water.
2. Add 1¼ gallons of vinegar to the water in the tank.
3. With a clean disinfected brush, wash the inside surfaces of the tank.
4. Turn on the pumps and open each nozzle to rinse all the tubes.
5. Once the tank has been thoroughly cleaned and each tube has been flushed with the solution, drain the tank.
6. Thoroughly rinse the tank with fresh water and again open all the nozzles to rinse all the drinking tubes.
7. Drain the tank.
8. Turn off the pumps.

Note: Wenger recommends vinegar as a safe alternative to the bleach cleaning procedure recommended in the SHURflo® data sheet.

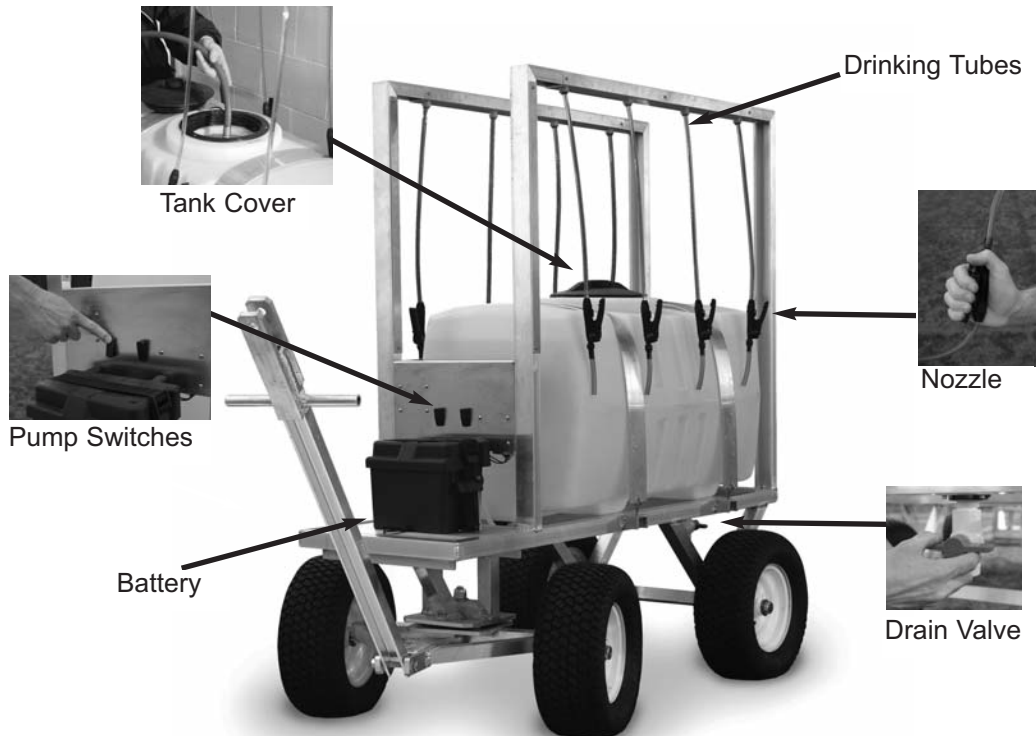

REPLACEMENT PARTS LIST

HYDRATE CART REPLACEMENT PARTS LIST

<u>Item</u>	<u>Qty</u>	<u>Description</u>
1	2	Pump
2	1	Battery
3	4	Tire
4	1	Handle / Hitch
5	8	Drinking Nozzle
6	2	Switch

