

GearBoss[®] Shelving

GearBoss Shelving is designed for needs all over the facility from athletics to fine arts to general storage areas. The unique design provides cantilevered shelves keeping areas underneath free from supports and available for carts and mobile storage. The system is easily installed and shelves and accessories can be adjusted quickly without tools. GearBoss shelving comes in standard bays that are 4'w x 8'h (1219 x 2438 mm) and can be mounted on block wall and wood or metal stud walls.

Intended Use

- The GearBoss shelving system is intended to maximize storage density in areas where there is storage need and space limitations
- The GearBoss shelving system is intended for indoor use in normal ambient temperature and humidity conditions - components must not be exposed to prolonged outside weather conditions
- The Gearboss shelving system is intended to be installed on floors with less than 1" (25 mm) of variation over the run of shelving

Specifications

- Galvanized 2" (51 mm) square 12-gauge steel uprights with galvanized 14-gauge shelf support bracket and 14-gauge tube support brackets
- Durable silver powder-coat paint finish
- Each bay section measures approximately 4'w x 8'h (1219 x 2438 mm)
- Each 4'w (1219 mm) bay is rated for 1000 lb (454 kg) evenly distributed
- Shipped ready-to-assemble with detailed instructions; Wenger assembly and installation is optional
- Patent and patents pending
- Ten-year warranty

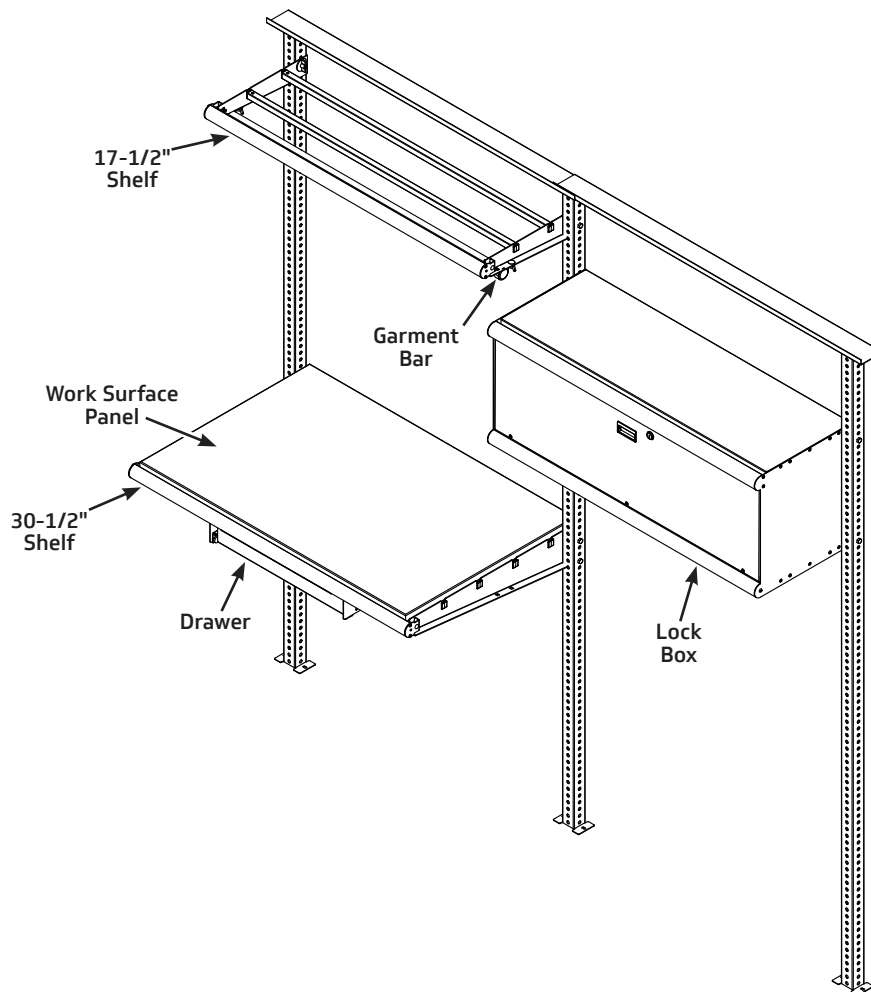

Accessories

Shelves, 30-1/2" and 17-1/2"

- 30-1/2" (775 mm) cantilevered shelf with 4 support tubes spaced 5-1/4" (133 mm)
- 17-1/2" (445 mm) cantilevered shelf with 2 support tubes spaced 5-1/4" (133 mm)
- Shelves can be mounted and adjusted in 1" (25 mm) increments without tools
- Both shelves fronted with a contoured aluminum extrusion with a 3/8" (9 mm) lip to retain a hardboard insert if necessary
- Each shelf is rated for 250 lb (113 kg) evenly distributed, not to exceed 1,000 lb (454 kg) per bay
- All steel parts have a durable silver powder-coat paint finish
- Shelf brackets are formed 12-gauge steel
- Shelf support are 14-gauge 7/8" (22 mm) steel tubes

Work Surface Panel

- 29-1/4" x 44-3/4" (743 x 1137 mm) panel lays directly inside a 30-1/2" shelf
- 1-1/8" (29 mm) graphite polyester laminated particle board with PVC edge banding - black only

Drawer

- Mounts to underside of a work surface panel accessory for a 30-1/2" shelf
- 14-gauge steel construction
- Durable black powder-coat paint finish
- Rated for 100 lb (45 kg) evenly distributed

Garment Bar/Hanging Bar

- 48" x 1-1/2" (1219 x 38 mm) x 14-gauge round steel tube
- All steel parts have a durable black powder-coat paint finish
- Durable black powder-coat paint finish
- Mounts to underside of shelves without tools
- Rated for 100 lb (45 kg) evenly distributed
- Interchangeable companion products: football helmet hanger, shoulder pad hanger - long, shoulder pad hanger - short

Lock Box

- Door is hinged at the bottom so it may drop and stay open for easy access
- Sides, top and bottom panels are 16-gauge steel
- Features upper and lower contoured aluminum extrusions, a key tab-lock and laminated wood door
- Door is 5/8" (16 mm) graphite pebble polyester laminated board with PVC edge banding - black only
- Rated for 100 lb (45 kg) evenly distributed
- Mounted and adjustable without tools
- Dimensions: 16" x 18" x 46" (406 x 457 x 1168 mm)

Peg Board Back

- Mounts directly onto existing shelf banks
- Rated for 40 lb (18 kg) evenly distributed
- The 1/4" (6 mm) thick peg board material is not supplied by Wenger and must be purchased separately



© 2024 Wenger Corporation
USA/2024-03

Minnesota Location

Wenger Phone 800.4WENGER (493-6437) Wenger Worldwide +1.507.455.4100 | Parts & Service 800.887.7145 | wengercorp.com
GearBoss Phone 800.493.6437 | gearboss.com
555 Park Drive, PO Box 448 | Owatonna | MN 55060

New York Location

J.R. Clancy Phone 800.836.1885 JR Clancy Worldwide +1.315.451.3440 | jrclancy.com | 7041 Interstate Island Road | Syracuse | NY 13209