

Mule Block Swivel & Stands

- Swivels may be added to mule blocks to allow swivel and pivot to meet site conditions
- Stands support mule blocks where other structural steel is not available
- Mule block stands must be welded in place after alignment – consult the factory for specific information
- Three-year warranty against defects in materials or workmanship is provided on all J.R. Clancy equipment, additional warranty information is available at jrclancy.com

Dimensions

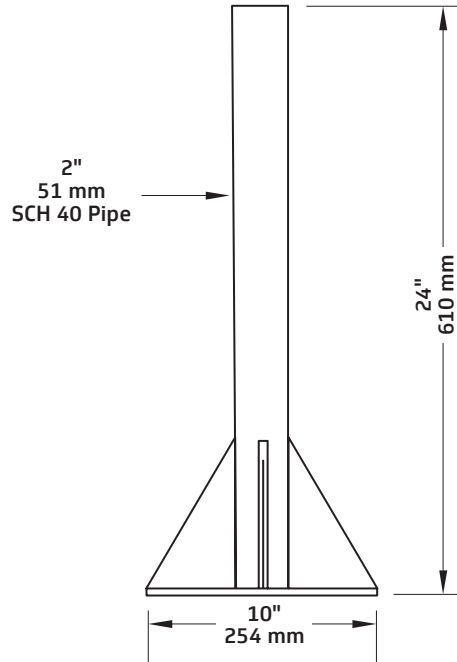

**Mule Block Swivel Stand
5C2-850S**

Order Information

Number	Description	Weight
5C2-SWIVEL	8" (203 mm) Mule Block Swivel	15 lb (6.8 kg)
5C2-850S	Mule Block Stand for 8" (203 mm), 1 & 2 line blocks	30 lb (13.6 kg)
5C2-850HS	Mule Block Stand for 8" (203 mm), 4 & 8 line blocks	50 lb (22.6 kg)

