

Quadratic Ceiling Diffuser Panel

- New diffuser designed to work very effectively over a frequency range of 750 to 3300 Hz.
- Diffuser designed based on the quadratic theory using a series of four different well depths with seven wells per sequence and three sequences per panel.
- Wells are 2.1" (5 cm) wide with a maximum depth of 5.2" (13 cm).
- Manufactures standard construction of Geon X1502 - 170 - 5001 thermo molded plastic, 1/8" (3 mm) material thickness.
- Made from PVC/acrylic plastic which meets Class A flame spread and smoke developed requirements according to NFPA 101 Life Safety Code Requirements.
- Surface is paintable by others using acrylic based paint only.
- Recyclable.
- 4' x 4' (122 x 122 cm) size made for ceiling lay in applications.
- Weight - 35 lbs (16 kg).
- Detailed polar plots of TEF measurements available on request.
- Five-year warranty.

Installation Notes:

- Tee-Grid System must meet or exceed intermediate duty A.S.T.M. specifications.
- A minimum of 12" (30 cm) is needed between Tee-Grid System and any obstructions above Tee-Grid System.

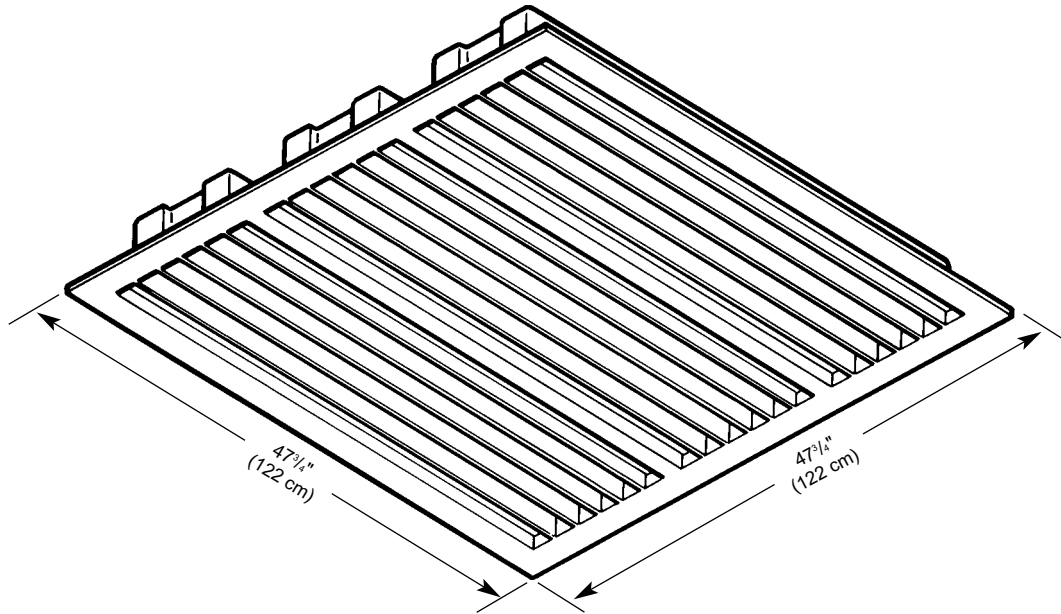

Absorption Coefficients

• Upper Design Frequency (f max.)	3300 Hz
• Lower Design Frequency (f min.)	750 Hz
• Number of wells (N)	7
• Largest Sequence (S max.)	4
• Maximum well depth (d max.)	5.2" (13 cm)
• Well width	2.1" (5 cm)
• Number of sequences per panel	3

	Octive Bands					
Frequency (Hz)	125	250	500	1000	2000	4000
Absorption Coefficient	0.36	0.54	0.59	0.43	0.24	0.19
(E-400 Mounting)						

WENGER CORPORATION
 555 Park Drive, PO Box 448
 Owatonna, MN 55060-0448
 Phone 800.4WENGER
 Fax 507.455.4258
 Customer Service 800.887.7145

CANADA
 (Dufferin Liberty Center)
 219 Dufferin, Suite 117C
 Toronto, Ontario M6K 3J1
 Phone 800.268.0148
 Fax 416.754.3996

EUROPE
 Tel +31 26 376 0500
 wenger-europe.com

BEIJING REPRESENTATIVE
OFFICE OF WENGER
 Tel 0086-10-84972502
 Fax 0086-10-84972575

WORLDWIDE
 Phone 507.455.4100
 Fax 507.444.0685

WEB SITE
 wengercorp.com