

Backstage® Makeup Station

The Backstage Makeup Station will provide performers with a correct and convenient tabletop environment for applying makeup and creating other visual effects. The Backstage Makeup Station includes a large mirror, shadow-free lighting, an electrical outlet, a carry handle, and a grounded power cord.

- 187A011 Backstage Makeup Station with 6 lights and white accent panels.

The Mirror

- Construction: High quality glass and silvering laminated to a steel backer to prevent separation of shards if broken.
- Size: 20³/₄" wide x 22³/₄" high (53 x 58 cm).

The Mirror Surround

- Construction: Extruded matte white aluminum with white accents. Rugged powder-coat paint finish. Base is shaped for compact storage front-to-back.
- Handle on top for transporting is part of mirror surround.

The Lighting

- 6 medium base sockets provided for 60W incandescents or 15W swirl fluorescents. Bulbs are protected by wire cages made from ³/₁₆" (5 mm) diameter steel wire. Cages are permanently mounted, but allow easy bulb replacement (bulbs not included).

The Electrics

- A rocker switch and grounded outlet are mounted on the lower right side of the mirror surround.
- Switch controls lights only.
- Attached power cord is 10' (3 m) long and stores itself.
- UL® listed. Meets NEC (National Electric Code) requirements.

The Options

- 187A021 Lightweight canvas padded Dust Cover protects the Backstage Makeup Station from damage and collection of dust.

Physical Dimensions

- Overall Width: 33" (84 cm) (bulb cage-to-bulb cage).
- Overall Height: 33¹/₄" (85 cm).
- Overall Depth: 9³/₈" (24 cm).
- Storage Depth: 9³/₈" (24 cm) first unit, 6¹/₂" (17 cm) each additional unit.
- Weight: 35 lbs (16 kg).
- Environmental attributes and LEED compliance for this product can be found at www.wengercorp.com/GREEN or by contacting your Wenger representative.

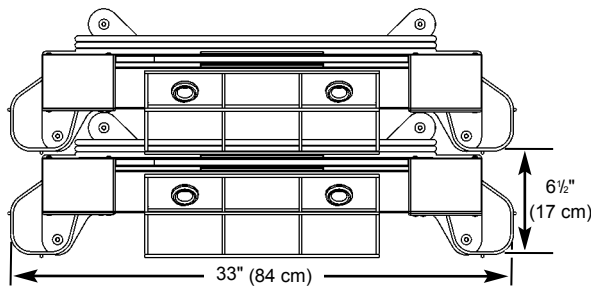
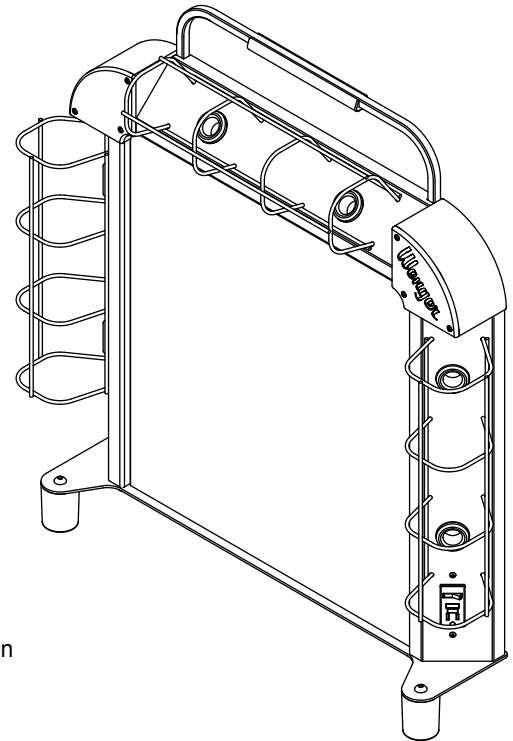

Nested View

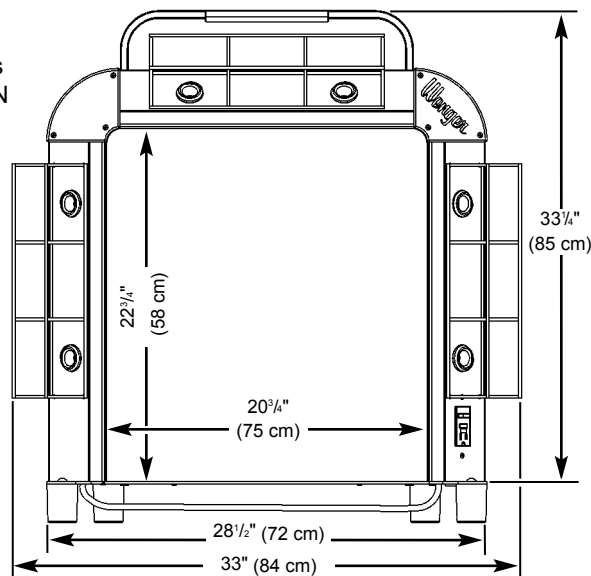

Front View

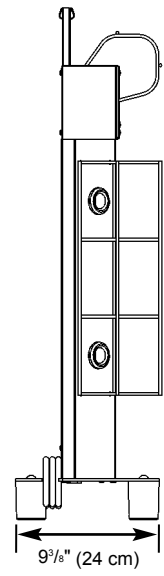

Side View

WENGER CORPORATION

555 Park Drive, PO Box 448
Owatonna, MN 55060-0448
Phone 800.4WENGER (493.6437)
Fax 507.455.4258
Customer Service 800.887.7145

WENGER CORPORATION

CANADIAN REPRESENTATIVE OFFICE
Phone 800.268.0148

WORLDWIDE

Phone 507.455.4100
Fax 507.774.8576

WEB SITE

wengercorp.com