

Bravo™ Stand

- 1020000 7 lbs (3.1 kg).
- Polycarbonate desk with accessory shelf available in five colors: Red, Green, Blue, Plum and Black. Chrome finish is also available.
- Base and tube available in Black or Grey powder-coat paint finish for maximum durability. Chrome finish is also available.
- 20³/₈" x 13¹/₂" (52 x 35 cm) desk with 19" x 2¹/₂" (49 x 6 cm) accessory shelf.
- Brass spring height adjustment mechanism adjusts height from 22¹/₂" to 46¹/₂" (57 to 118 cm) (desk lip to floor).
- GREENGUARD Indoor Air Quality Certified® and GREENGUARD Children & SchoolsSM Certified.
- Environmental attributes and LEED compliance for these products can be found at www.wengercorp.com/GREEN or by contacting your Wenger representative.
- Five-year warranty.

Accessories

The following music stand lights are available:

- Classic Electric Music Stand Light
- Duet LED Music Stand Light
- Duet II LED Music Stand Light
- Hammerhead LED Music Stand Light
- Encore LED Music Stand Light
- Orchestra LED Music Stand Light

See the Music Stand Lights Technical Sheet for details.

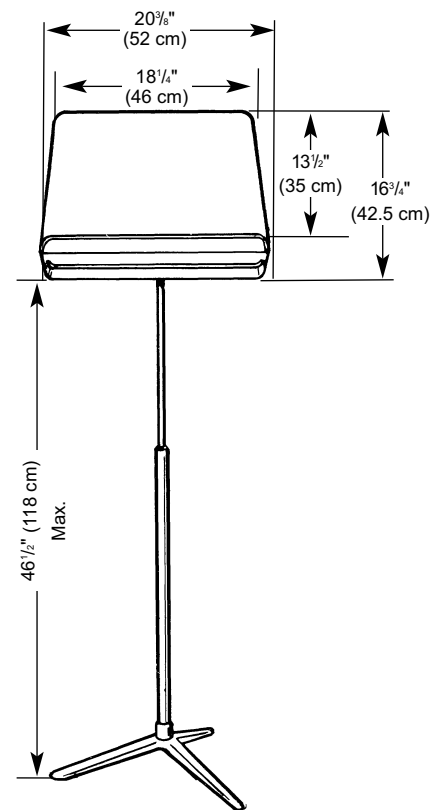
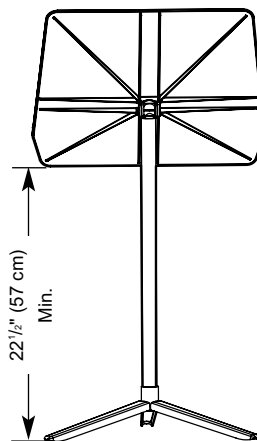
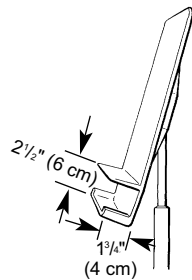

Accessories continued on next page.

Accessories (continued)

Large Stand Move and Store Cart

- 039C202 38 lbs (17 kg).
- Holds 18 Bravo™ Stands.
- Large center pivot wheels for maneuverability.
- Loads and unloads from both ends.
- 14-gauge 1" x 1½" (2.5 x 4 cm) and 16-gauge 7/8" (2 cm) steel tubing with 8" (20 cm) wheels and 5" (13 cm) heavy-duty casters.
- Stores compactly in 27½" x 68" (70 x 173 cm) floor space. Allow 60" (153 cm) for height.

Small Stand Move and Store Cart

- 039D201 21 lbs (9.5 kg).
- Holds 9 Bravo™ Stands.
- Two-wheel cart design allows transport up and down stairs.
- 14-gauge 1" x 1½" (2.5 x 4 cm) and 16-gauge 7/8" (2 cm) steel tubing with 8" (20 cm) heavy-duty wheels.
- Stores compactly in 27½" x 36" (70 x 91 cm) floor space. Allow 60" (153 cm) for height.

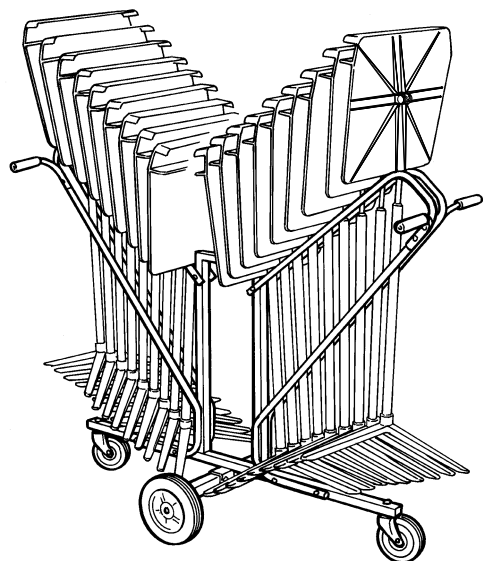

Large Move and Store Cart

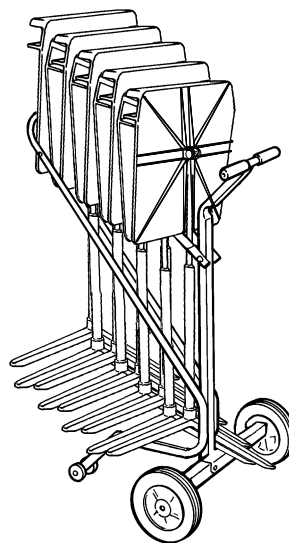

Small Move and Store Cart

WENGER CORPORATION

555 Park Drive, PO Box 448
Owatonna, MN 55060-0448
Phone 800.4WENGER (493.6437)
Fax 507.455.4258
Customer Service 800.887.7145

WENGER CORPORATION

CANADIAN REPRESENTATIVE OFFICE
Phone 800.268.0148

WORLDWIDE

Phone 507.455.4100
Fax 507.774.8576

WEB SITE

wengercorp.com