

Cellist Chair

- 0940000 18 lbs (8.2 kg).
- Seat is rugged ABS material with 2" (5 cm) polyfoam cushioning. Back has 1¾" (4.4 cm) polyfoam back cushioning over 5/16" (0.8 cm) wood.
- Seat and back are covered with 100% polypropylene fabric, available in six colors: Black, Green, Blue, Plum, Red, Grey.
- Seat is tilted forward 1.3° to provide the ideal lean and balance requirements of a cellist.
- Forward-positioned back stabilizes and supports the cellist posture.
- 16-gauge 7/8" (22 mm) square tube frame, designed and welded to give support around entire outer edge of both seat and back.
- Available in standard heights of 18½" (47 cm) and 19½" (50 cm).
- Black or Grey powder-coat paint finish for maximum durability. Chrome finish is also available.
- Stacks for compact storage, up to 10 chairs on a cart; 8 without a cart.
- Durable, specially designed floor glides provide stability when seated and ease of movement when arranging chairs.
- ANSI/BIFMA x 5.1-2002.
- California Technical Bulletin 117 compliant.
- Environmental attributes and LEED compliance for this product can be found at www.wengercorp.com/GREEN or by contacting your Wenger representative.
- Five-year warranty.

Move 'N Store Cart

- 127A261 30 lbs (14 kg).
- Stack, move and store up to 10 Cellist chairs.
- 16-gauge steel construction with easy-roll casters.

Dust Cover

- 054D500.
- Vinyl Coated Polypropylene.
- For use with chairs stacked on cart.

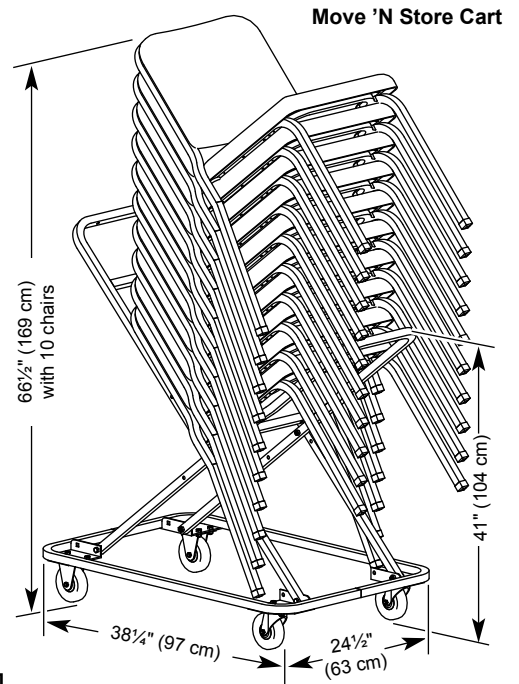

| Chair Height | A | B | C | D |
|--------------|--------------|--|---|---|
| 18½" (47 cm) | 19¼" (49 cm) | 19¼" (49 cm) | 19¼" (49 cm) | 35 ⁹ / ₃₂ " (90 cm) |
| 19½" (50 cm) | 20¼" (51 cm) | 19 ⁵ / ₈ " (50 cm) | 17 ⁷ / ₁₆ " (49 cm) | 36 ⁹ / ₃₂ " (92 cm) |

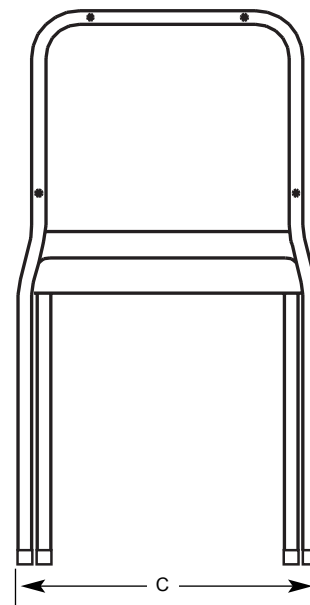
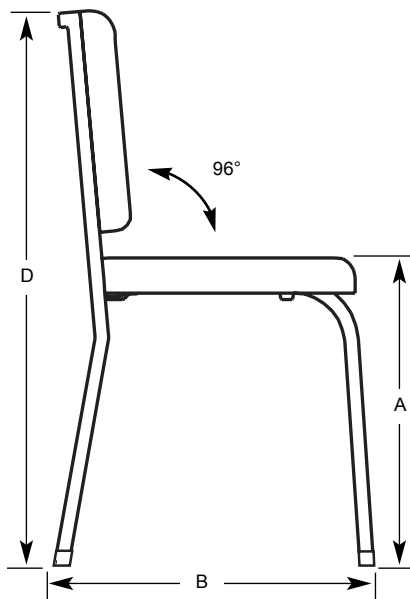

WENGER CORPORATION

555 Park Drive, PO Box 448
Owatonna, MN 55060-0448
Phone 800.4WENGER (493.6437)
Fax 507.455.4258
Customer Service 800.887.7145

WENGER CORPORATION

CANADIAN REPRESENTATIVE OFFICE
Phone 800.268.0148

WORLDWIDE

Phone 507.455.4100
Fax 507.774.8576

WEB SITE

wengercorp.com