

Expanded Music Lab Workstation

- 225C103._ 280 lbs (127 kg).
- Lower pull-out tray for computer keyboard, 29" wide x 14" deep (74 cm x 36 cm).
- Holds 88-key music keyboards/synthesizers up to 16" deep (91 cm).
- Desk is 1¹/₈" (3 cm) thick industrial grade particleboard core with polyester laminate, music keyboard space is 48" wide x 16" deep (122 x 41 cm).
- Sides and upper shelf panel constructed of 3/4" (19 mm) thick industrial grade particleboard with polyester laminate finish.
- Back panels constructed of 3/4" (19 mm) thick plywood core with polyester laminate finish.
- Low profile monitor space designed for monitors up to 20" wide (51 cm).
- Edging is 1/8" 3mm radiused PVC.
- Eight single spaces of rack mounting provided.
- 8-outlet power strip with remote master switch, 15 amp, 120VAC, UL listed, 12' (366 cm) long power cord, surge suppression, accommodates up to 4 transformer type plugs, lifetime warranty.
- Four swivel 4" (10 cm) diameter rubber casters, two locking.
- Two lockable rear services doors for easy access to wiring.
- Lower level shelf holds external hard drives, 18" high x 18" deep (46 x 46 cm).
- Pull-out tablet arm, 10" wide x 15" deep (25 x 38 cm).
- Self mounting or free-standing 20" wide x 12" high (51 x 30 cm) acrylic music holder included.
- Brass headphone hook included.
- Six wire management clips included.
- Rolls through 36" (91 cm) standard doorway.
- Base frame constructed of 16 gauge, 2¹/₄" (5.7 cm) square tube, with telescoping adjustable leg in zinc plated finish.
- Adjustable leg adjusts in one inch increments from 28¹/₂" to 35¹/₂" high (72 x 90 cm), meets ADA requirements for handicap access.
- GREENGUARD Indoor Air Quality Certified® and GREENGUARD Children & SchoolsSM Certified.
- Environmental attributes and LEED compliance for this product can be found at www.wengercorp.com/GREEN or by contacting your Wenger representative.
- Overall dimensions:
61¹/₂" wide x 39" high x 32" deep (156 x 99 x 81 cm).
- Shipped ready to assemble.
- Ten-year warranty.

Accessories

Workstation Chair

- 223A010 without arms 30 lbs (14 kg).
- 223A020 with arms 36 lbs (16 kg).
- Ergonomic task chair.
- Pneumatic height adjustment.
- Six fabric colors available.

Acrylic Music Holder

- 222A151 2.5 lbs (1 kg).
- Slides over desk or sits on top.
- 20" wide x 11¹/₂" high (51 x 29 cm).

Power Strip

- 220B008 5 lbs (2 kg).
- 8 outlets, 15 amps, 120VAC.

Wire Clips

- 220A007 1 lb (0.45 kg).
- Package of eight.

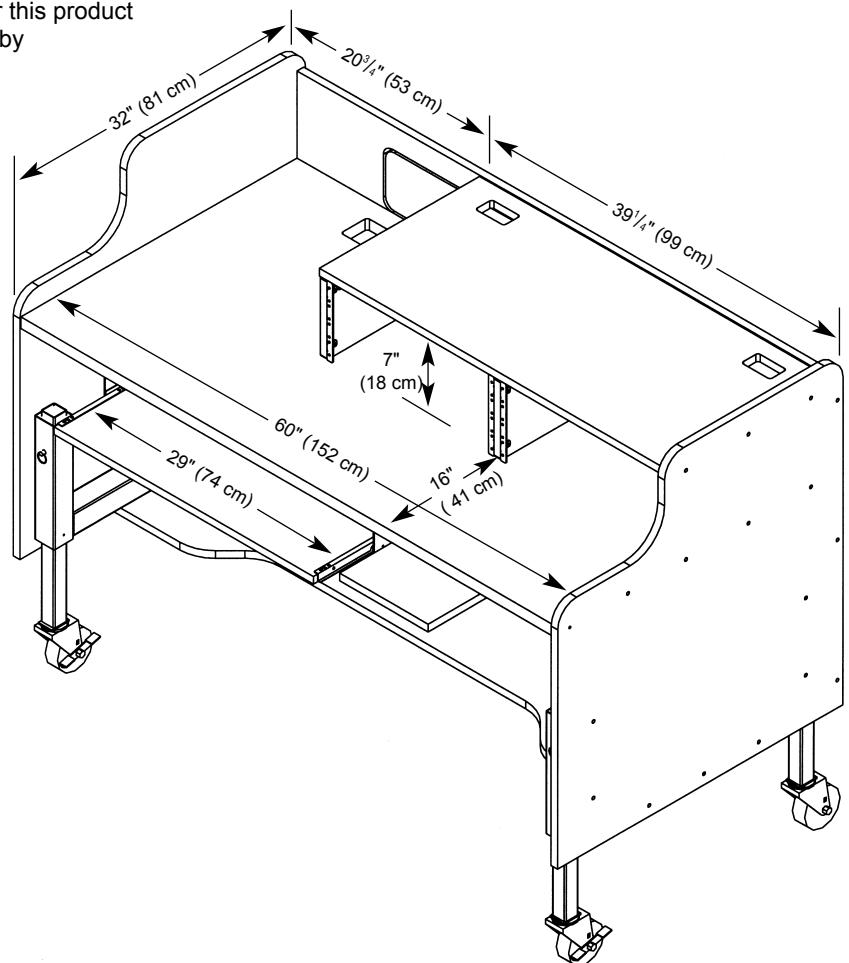

WENGER CORPORATION

555 Park Drive, PO Box 448
Owatonna, MN 55060-0448
Phone 800.4WENGER (493.6437)
Fax 507.455.4258
Customer Service 800.887.7145

WENGER CORPORATION

CANADIAN REPRESENTATIVE OFFICE
Phone 800.268.0148

WORLDWIDE

Phone 507.455.4100
Fax 507.774.8576

WEB SITE

wengercorp.com