

flipFORMS®

- 025D002 Blue/Grey, 025D003 Green/Grey, 025D004 Yellow/Grey, 025D005 Red/Grey, 025D027 Grey/Grey, 025D028 Black/Black (100 lbs) (45 kg).
- Takes on three basic shapes for use as a one tier platform, two tier or three tier unit.
- Has two moveable sections hinged onto a core unit. Flip larger back section onto core for two tiers. Flip both back and front sections onto core unit for three tiers. When both sections are down, flipFORMS can be used as a one tier raised platform.
- Blow molded, high-density polyethylene plastic shell provides an easy-to-clean surface that's super tough.
- Shell has skid resistant texture molded into surface for added safety and surefootedness.
- Replaceable tops.
- Recessed, molded handholds on front and sides for easy positioning or carrying.
- Built-in wheels in reinforced wheel pockets provide one-person portability.
- Units store in an upright position.
- Twelve 1½" (4 cm) square skid-resistant, non-marring glides positioned on bottom of the unit. Secured by recessed screws.
- Patented hinge design maintains flat surface in all positions.
- Environmental attributes and LEED compliance for this product can be found at www.wengercorp.com/GREEN or by contacting your Wenger representative.
- Five-year warranty.

Capacity	Seating (2-step)	Standing (3-step)
Grades 1-3	8 per unit	12 per unit (Bottom step is row #1)
Grades 4-12	6 per unit	12 per unit (Floor is row #1)

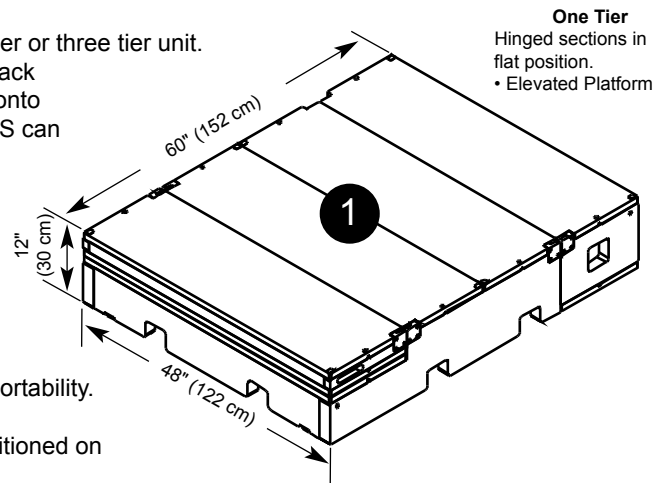

One Tier
Hinged sections in flat position.
• Elevated Platform

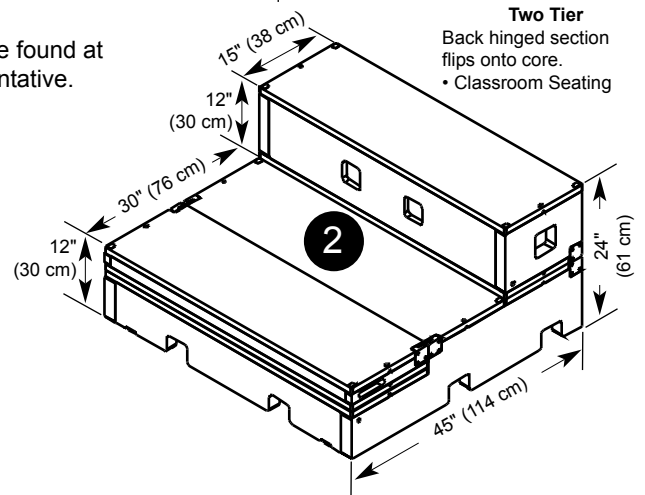

Two Tier
Back hinged section flips onto core.
• Classroom Seating

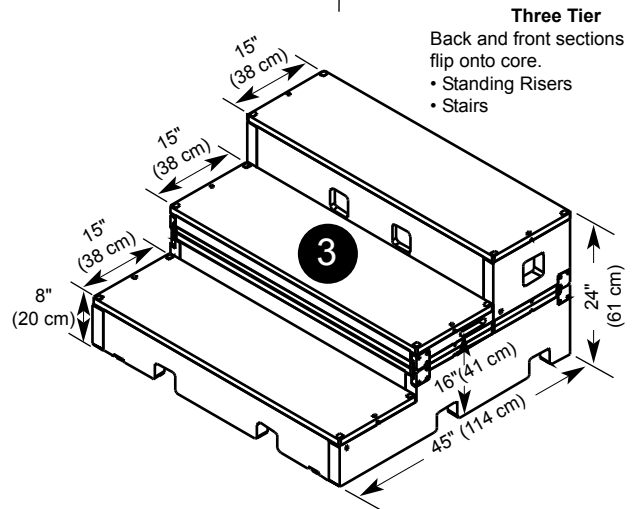

Three Tier
Back and front sections flip onto core.
• Standing Risers
• Stairs

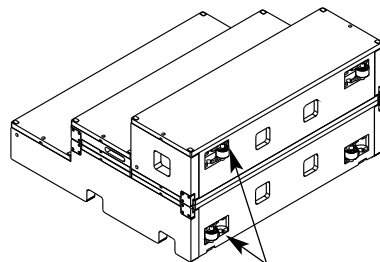

Wheels and recessed handholds make it easy to transport flipFORMS.

Units roll, nest and store in upright position.

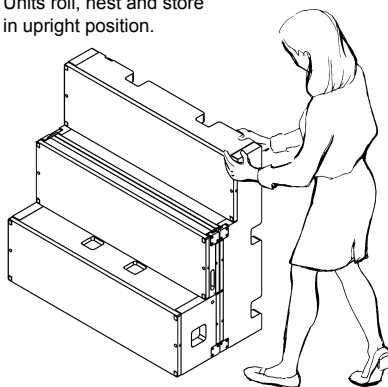

WENGER CORPORATION
555 Park Drive, PO Box 448
Owatonna, MN 55060-0448
Phone 800.4WENGER (493.6437)
Fax 507.455.4258
Customer Service 800.887.7145

WENGER CORPORATION
CANADIAN REPRESENTATIVE OFFICE
Phone 800.268.0148

WORLDWIDE
Phone 507.455.4100
Fax 507.774.8576

WEB SITE
wengercorp.com