

GearBoss[®] Sports Storage System

GearBoss is an equipment storage and transportation solution designed to transform your equipment room into a point of pride. GearBoss is a high-density storage solution that uses an innovative system of tracks and rolling carts and accessories to reduce the square footage of your storage area by at least half. GearBoss units are designed to encourage airflow and improve sanitation and odor issues. The modular system features accessories specific for the needs of bulky equipment like helmets and shoulder pads. Accessories like panels and doors can be added for security, and in matching school colors they present an unmistakable message of program pride.

Intended Use

- The GearBoss system is intended for indoor use in normal ambient temperature and humidity conditions - components must not be exposed to prolong outside weather conditions.
- Attics are designed only to be used on the 48" (122 cm) X-Cart.

System Description

- Attics come in two heights 25⁵/₈" (65 cm) and 37⁵/₈" (96 cm).
- Welded end frames made from 2" (5 cm) diameter x 16 gauge steel tubing.
- Resistant welded heavy-duty steel wire grill end frames.
- Durable powder paint coat finish.
- Roof panel constructed from solid ⁵/₈" (15.9 mm) MDF and with aluminum extrusions, the roof assembly is rated for 150 lbs (68 kg) load.
- Designed to be accessorized with the 24" (61 cm) wide wire shelves.
- Approximate weights:
 - Short attic, 115 lbs (52 kg)
 - Tall attic, 123 lbs (56 kg).
- Shipped ready to assemble.
- Part Numbers:
 - Short attic 240A803
 - Tall attic 240A804
- Five-year warranty.

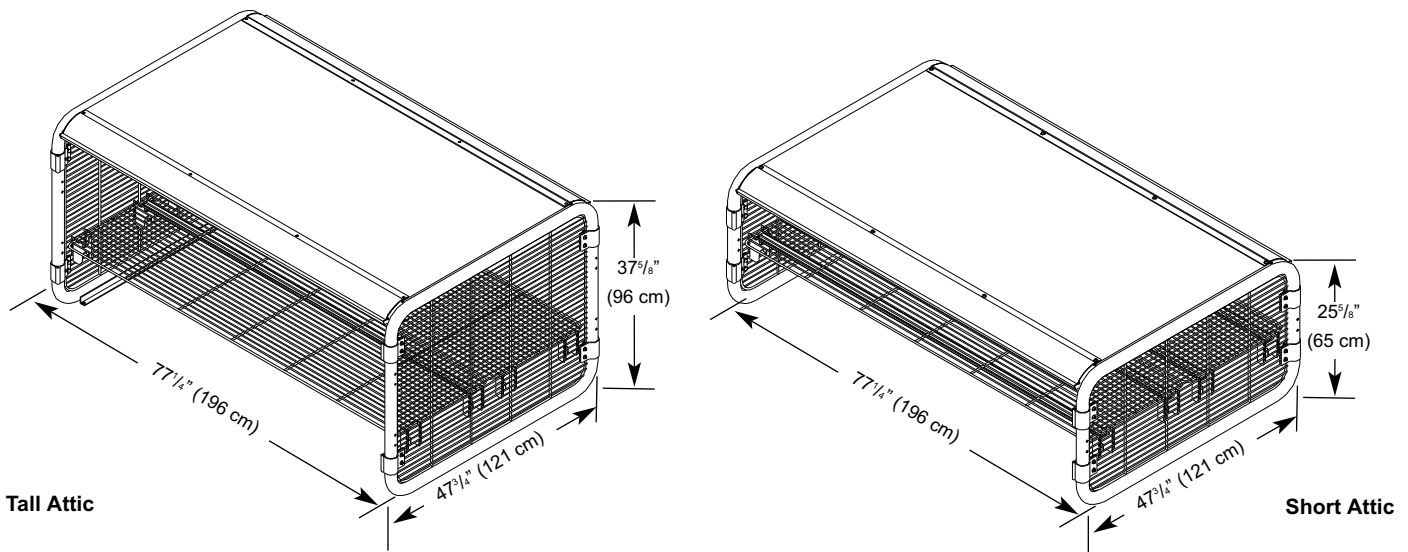

WENGER CORPORATION

555 Park Drive, PO Box 448
Owatonna, MN 55060-0448
Phone 800.4WENGER (493.6437)
Fax 507.455.4258
Customer Service 800.887.7145

WENGER CORPORATION

CANADIAN REPRESENTATIVE OFFICE
Phone 800.268.0148

WORLDWIDE

Phone 507.455.4100
Fax 507.774.8576

WEB SITE

wengercorp.com