

## GearBoss® Sports Storage System

The GearBOSS Mobile Kiosk by Wenger is a self contained, mobile merchandising kiosk that allows you to follow your fans, wherever they go. All of your logo gear is neatly secured inside the enclosed unit while moving from venue to venue. Panels open up in seconds to create your kiosk. Eight removable bins allow different athletic programs, boosters or school clubs to keep inventory in their own bin. Move beyond candy sales and car washes to real revenue generation.

### Intended Use

- Organize school spirit items for sale at multiple locations.
- Travels to the gym, field, parking lot, school hall.
- Hand break for easy mobility.
- Move your fund raising efforts to a new level.

### Specifications

- 240A007.1
- Heavy-duty chassis construction.
- Chassis is 1<sup>1</sup>/<sub>4</sub>" (3 cm) 16 gauge tube steel with 1<sup>1</sup>/<sub>4</sub>" (3 cm) square tube cross sections.
- Canopy – 0.10 inch thick aluminum attached to 18 gauge tube weldment.
- Side Doors – 3/4" thermofused composite wood core.
- Front Fold-Down Doors – 5/8" thermofused composite wood core.
- 42" (107 cm) counter height.
- Pneumatic 10" (25.4 cm) wheels with outdoor treads and sealed ball bearings.
- Closed dimensions - 72" long x 31" deep x 77" tall (183 x 79 x 196 cm).
- Open dimensions - 119<sup>1</sup>/<sub>2</sub>" long x 58" deep x 90" tall (304 x 147 x 229 cm).
- Bin measurements - 14<sup>3</sup>/<sub>16</sub>" wide x 27<sup>3</sup>/<sub>4</sub>" deep x 11<sup>1</sup>/<sub>8</sub>" tall (36 x 70.5 x 28 cm) (8 bins per cart).
- Display Panel Measurements
  - Side doors - 26<sup>3</sup>/<sub>8</sub>" wide x 61" tall (67 x 155 cm)
  - Back doors - 62<sup>5</sup>/<sub>8</sub>" wide x 31<sup>3</sup>/<sub>4</sub>" tall (159 x 81 cm).
- Slat Wall Starter Kit - 1 basket, 2 waterfalls, 18 hooks
- Slat wall is reinforced with aluminum channels to accept heavier loads and a wide variety of retail display hardware.
- GREENGUARD Indoor Air Quality Certified® and GREENGUARD Children & Schools<sup>SM</sup> Certified.
- Environmental attributes and LEED compliance for this product can be found at [www.wengercorp.com/GREEN](http://www.wengercorp.com/GREEN) or by contacting your Wenger representative.
- Weight (empty) - 550 lbs. (249.5 kg).
- 800 lbs. (363 kg) maximum load tires.
- Five-year warranty.

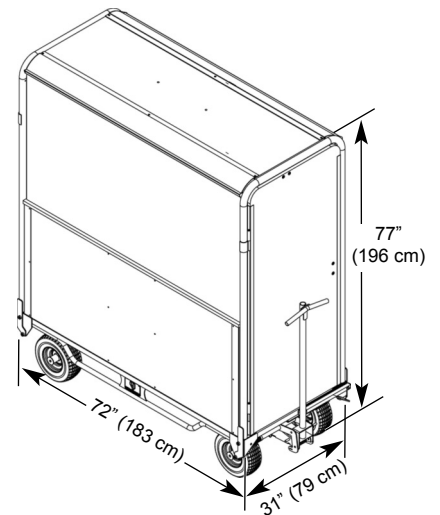
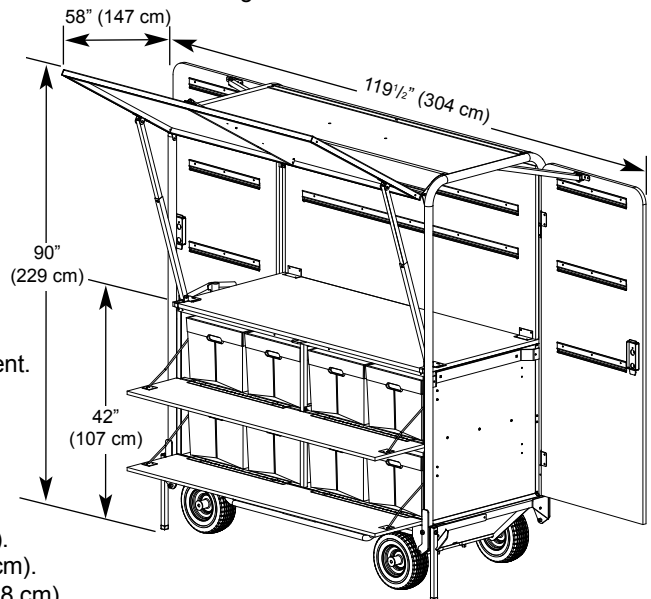

### Accessories

- Track lights - 2' (61 cm) track with 2 lights.
- Plug Strip - seven outlets.

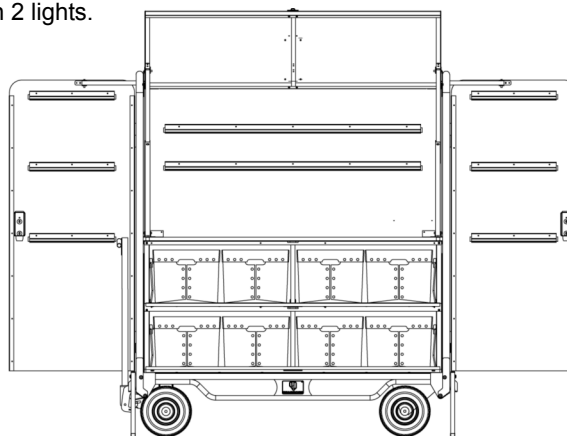

**WENGER CORPORATION**  
555 Park Drive, PO Box 448  
Owatonna, MN 55060-0448  
Phone 800.4WENGER (493.6437)  
Fax 507.455.4258  
Customer Service 800.887.7145

**WENGER CORPORATION**  
**CANADIAN REPRESENTATIVE OFFICE**  
Phone 800.268.0148

**WORLDWIDE**  
Phone 507.455.4100  
Fax 507.774.8576

**WEB SITE**  
[wengercorp.com](http://wengercorp.com)