

GearBoss® Wood Locker

GearBoss Wood Lockers feature open front athletic uniform and equipment storage available in an array of styles and finishes that represent excellence in team room design. Versatile construction provides for through-bolting to connect side-by-side units, allowing for easy removal of a single locker without disturbing other lockers. Steel base mounting fixture provides natural ventilation and height adjustment to compensate for uneven floors. The optional built-in foot locker provides power ventilation to dry cleats, socks and shoes. Available features and accessories include power ventilated shoulder pad and helmet drying racks, adjustable base, digitally-locked valuables compartment, lighted name plates and electrical outlet.

Intended Use

- The GearBoss Locker provides a cleanable, sanitary and fast drying storage solution in the team room.
- The GearBoss Locker is intended for indoor use in normal ambient temperature and humidity conditions - components must not be exposed to prolonged outside weather conditions.

Specifications

- Locker sizes:
18"-36" wide available in 2" increments x 78" high x 24" deep (46-91 cm wide available in 5 cm increments x 198 x 61 cm).
Depending on overall locker width, a hinged seat can be up to 29½" (75 cm) deep.
- Side Profiles can be Cut-Back, Straight or Contour.
- Constructed of ¾" (19 mm) composite wood core.
- Antimicrobial polyester laminated finish.
- Edging is ⅛" (3 mm) beveled PVC.
- Each locker seat is rated for 500 lbs. (227 kg).
- Each garment bar and garment hook is rated for 50 lbs (27 kg).
- 10-gauge, powder-coat painted garment hooks.
- Vented foot locker/debris drop-through and clean-out tray.
- Leveling powder-coat metal base raises unit from 1" to 2.5" (2 to 6 cm) off floor.
- 16-gauge, powder-coat painted floor plate.
- Zinc-plated levelers.
- Thermoformed ABS nameplate housing.
- Low-profile, chrome-plated through-connectors.
- Available in six core substrates to meet your specific needs: fire-rated, industrial-grade composite wood (standard), environmentally sensitive (no added urea formaldehyde), moisture-resistant, FSC certified, and Vencore (plywood).
- Shipped ready-to-assemble with detailed instructions. Wenger assembly and installation is optional.
- Product Number: 240A027.
- ADA-compliance.
- Ten-year warranty.

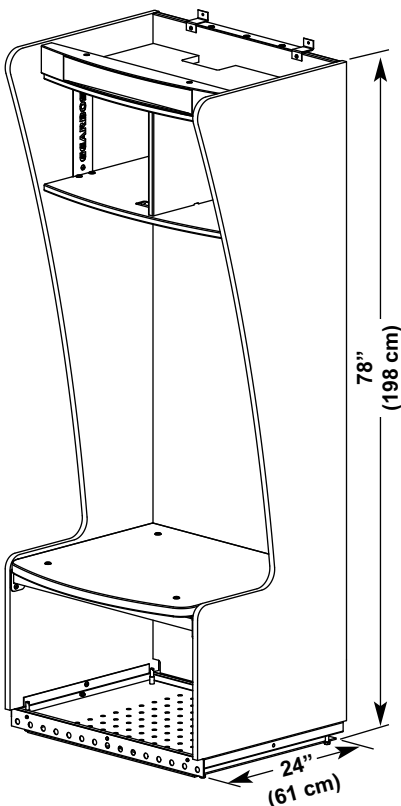

Cut-Back Side Profile

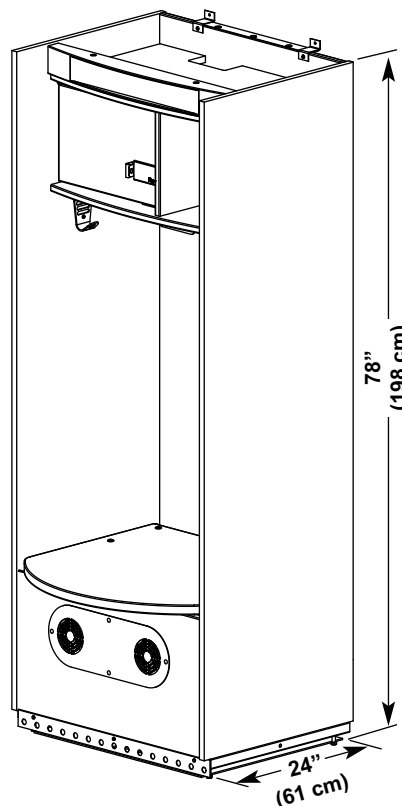

Straight Side Profile

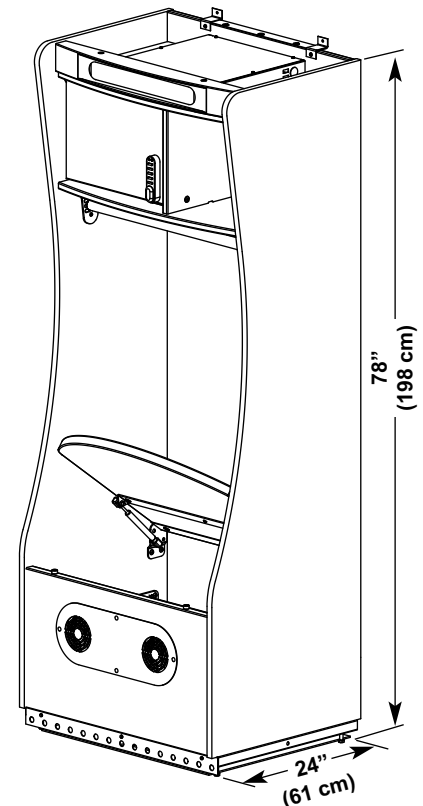

Contour Side Profile

Some Available Options Include:

- Helmet and shoulder pad topper (with or without fans).
- Electronics
 - lighted name plate
 - duplex outlet
 - 2 fans in helmet and shoulder pad topper
 - 2 fans in enclosed footlocker.
- Lockable valuables compartment
 - Programmable digital lock
 - Slide lock (for use with padlock).
- Hinged seat and enclosed footlocker with adjustable storage bars.
- Fixed seat and open foot locker.
- Garment hooks and garment bar combinations.
- Shelf in upper cubby.
- Shelf in open footlocker.

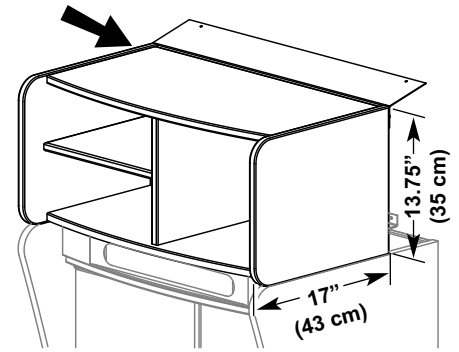

Storage Attic

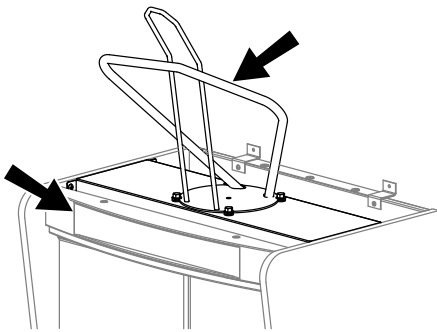

**Helmet and Shoulder Pad Holder
without Fans and Standard Marquee**

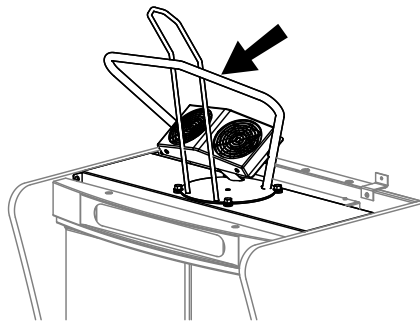

**Helmet and Shoulder Pad Holder
with Fans**

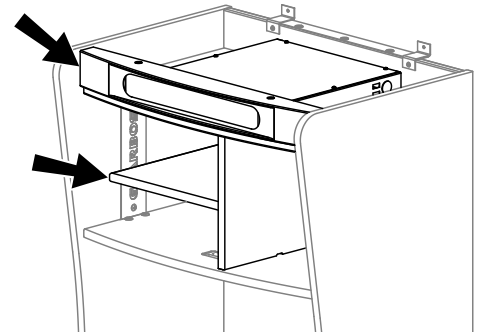

**Lighted Marquee
and Shelf in Cubby**

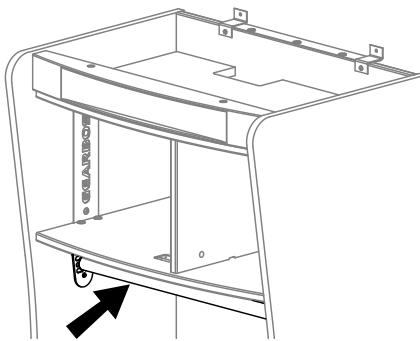

Garment Bar

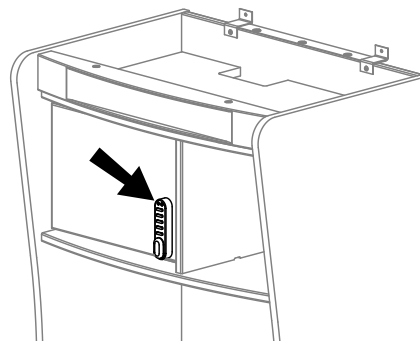

Programmable Digital Lock

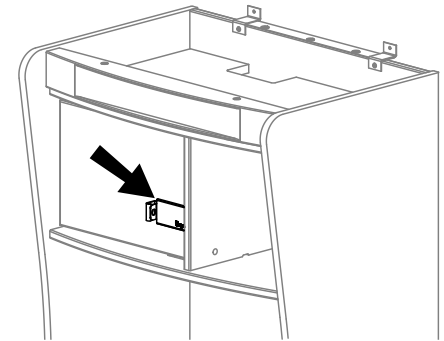

**Slide Lock
(for use with padlock)**

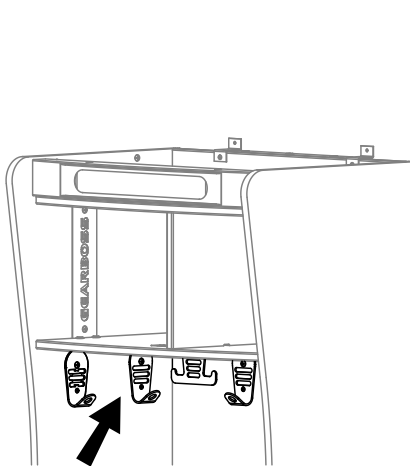

Garment Hooks

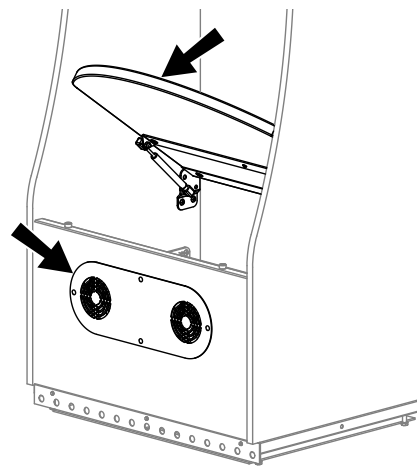

**Hinged Seat and Enclosed
Foot Locker with Fans**

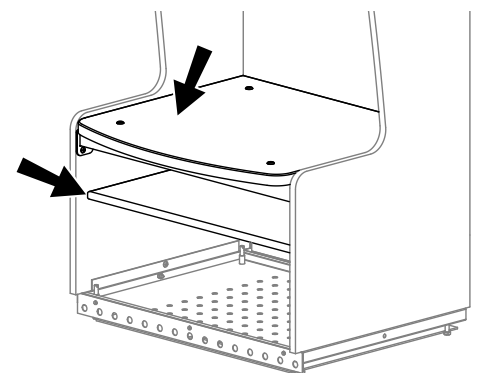

**Fixed Seat and
Open Foot Locker with Shelf**

WENGER CORPORATION
555 Park Drive, PO Box 448
Owatonna, MN 55060-0448
Phone 800.4WENGER (493.6437)
Fax 507.455.4258
Customer Service 800.887.7145

WENGER CORPORATION
CANADIAN REPRESENTATIVE OFFICE
Phone 800.268.0148

WORLDWIDE
Phone 507.455.4100
Fax 507.774.8576

WEB SITE
wengercorp.com

Wenger®
Your Performance Partner

US/C/1/04-2012/W