

# Music Lab Workstation

- 225C100\_ 217 lbs (98 kg).
- Lower pull-out tray for computer keyboard, 29" wide x 14" deep (74 x 36 cm).
- Holds 61-key music keyboards/synthesizers up to 16" deep (41 cm).
- Desk is 1/8" (3 cm) thick industrial grade particleboard core with polyester laminate, music keyboard space is 48" wide x 16" deep (122 x 41 cm).
- Sides and upper shelf panel constructed of 3/4" (19 mm) thick industrial grade particleboard with polyester laminate finish.
- Back panel constructed of 3/4" (19 mm) thick plywood core with polyester laminate finish.
- Low profile monitor space designed for monitors up to 20" wide (51 cm).
- Edging is 1/8" (3 mm) radiused PVC.
- Four single space rack mounting provided.
- 6-outlet power strip with 4' (122 cm) remote switch on cord, 15 amp, 120VAC, UL listed, 15' (4 m) long power cord with surge suppression.
- Four swivel 4" (10 cm) diameter rubber casters, two locking.
- Two lockable rear services doors for easy access to wiring.
- Lower level shelf holds external hard drives, 18" high x 18" deep (46 x 46 cm).
- Pull-out tablet arm, 10" wide x 15" deep (25 x 38 cm).
- Self mounting or free-standing 20" wide x 12" high (51 x 30 cm) acrylic music holder included.
- Brass headphone hook included.
- Six wire management clips included.
- Rolls through 36" (91 cm) standard doorway.
- Base frame constructed of 16 gauge, 2 1/4" (5.7 cm) square tube, with powder coat painted, bolted to side panels.
- GREENGUARD Indoor Air Quality Certified® and GREENGUARD Children & Schools<sup>SM</sup> Certified.
- Environmental attributes and LEED compliance for this product can be found at [www.wengercorp.com/GREEN](http://www.wengercorp.com/GREEN) or by contacting your Wenger representative.
- Overall dimensions: 49 1/2" wide x 39" high x 32" deep (126 x 99 x 81 cm).
- Shipped ready-to-assemble.
- Ten-year warranty.

## Accessories

### Workstation Chair

- 223A010 without arms 30 lbs (14 kg).
- 223A020 with arms 36 lbs (16 kg).
- Ergonomic task chair.
- Pneumatic height adjustment.
- Six fabric colors available.

### Acrylic Music Holder

- 222A151 5 lbs (2 kg).
- Slides over desk or sits on top.
- 20" wide x 11 1/2" high (51 x 29 cm).

### Power Strip

- X002222 2.5 lbs (1 kg).
- 6 outlets, 15 amps, 120VAC.
- Four hot, eleven switched outlets.

### Wire Clips

- 220A007 1 lb (0.45 kg).
- Package of eight.

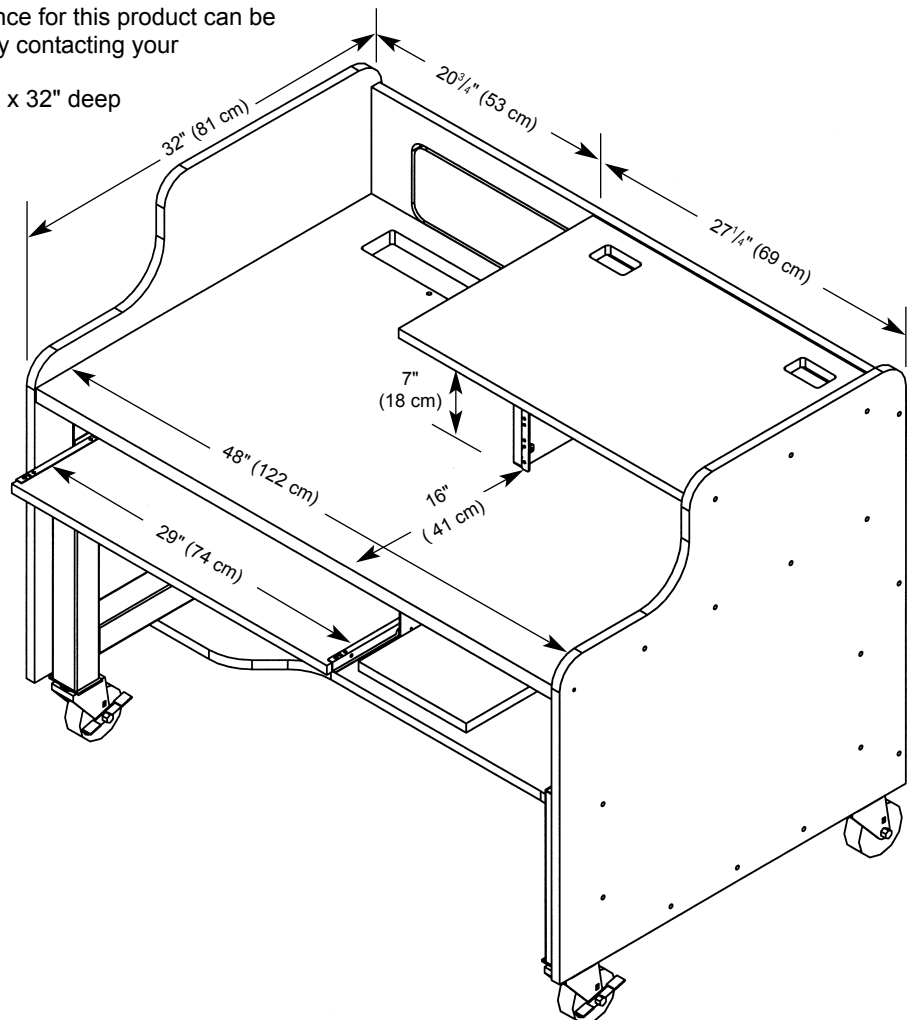

#### WENGER CORPORATION

555 Park Drive, PO Box 448  
 Owatonna, MN 55060-0448  
 Phone 800.4WENGER (493.6437)  
 Fax 507.455.4258  
 Customer Service 800.887.7145

#### WENGER CORPORATION

CANADIAN REPRESENTATIVE OFFICE  
 Phone 800.268.0148

#### WORLDWIDE

Phone 507.455.4100  
 Fax 507.774.8576

#### WEB SITE

[wengercorp.com](http://wengercorp.com)