

# Music Sorting Rack

- 173E050\_ 165 lbs. (74 kg).
- Contains 46 vertical slots for individual parts.
- Slot dimension: 1" thick x 10<sup>1</sup>/<sub>2</sub>" deep x 9" high (2.54 x 26 x 23 cm).
- 1/8" (3 mm)-hardboard dividers keep individual parts separated.
- Cabinet constructed of 3/4" (19 mm) thick industrial grade composite wood with polyester laminate finish in Wenger standard colors.
- 1/8" (3 mm)-thick PVC edgebanding.
- Instrumentation label provided for each slot.
- Includes four swivel casters.
- Includes two lower storage compartments for additional music.
- Cabinet is shipped assembled.
- Overall dimensions: 49<sup>5</sup>/<sub>8</sub>" wide x 25<sup>1</sup>/<sub>4</sub>" deep x 35<sup>1</sup>/<sub>16</sub>" high (126 x 64 x 89 cm).
- Optional full-length wood door - same construction as wall panels.
  - Doors must be included at the time of ordering as they can not be installed later.
  - Doors include heavy-duty 5-knuckle institutional ANSI/BHMA A156.9, Grade 1 hinge, through - bolted to cabinet wall.
- GREENGUARD Indoor Air Quality Certified® and GREENGUARD Children & Schools<sup>SM</sup> Certified.
- Environmental attributes and LEED compliance for this product can be found at [www.wengercorp.com/GREEN](http://www.wengercorp.com/GREEN) or by contacting your Wenger representative.
- Ten-year warranty.

## Accessories

- 173A052 25 lbs. (11 kg) industrial grade composite wood doors, lockable.

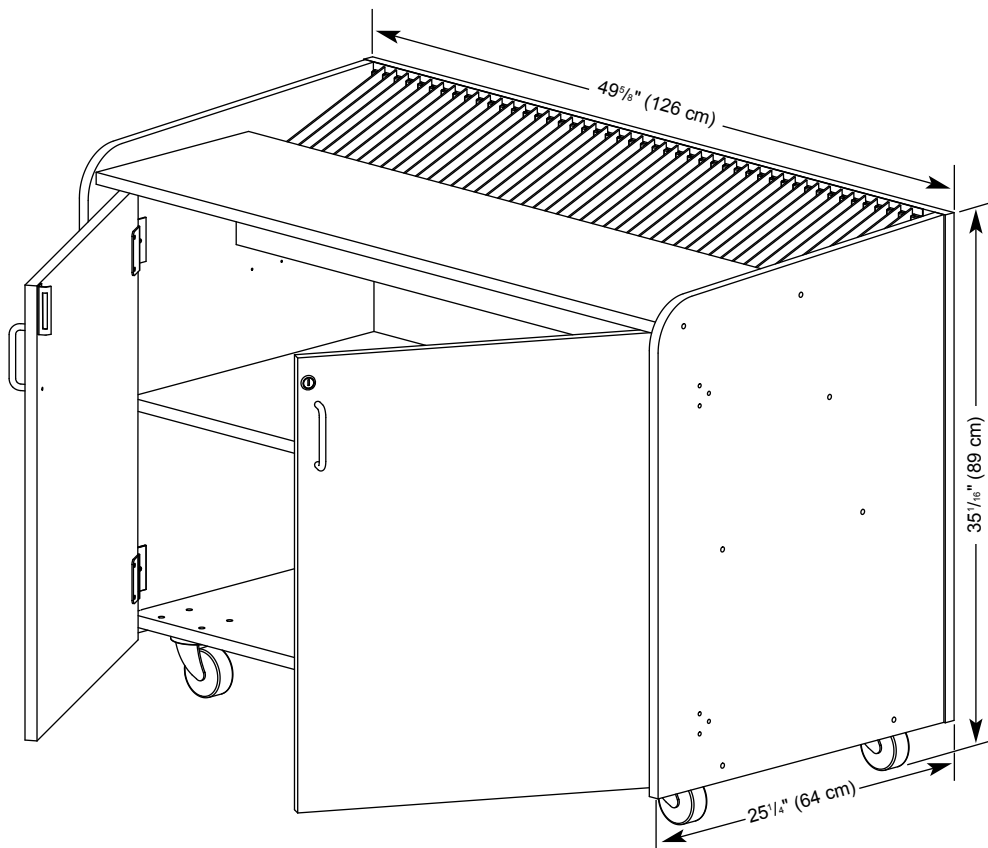

### WENGER CORPORATION

555 Park Drive, PO Box 448  
Owatonna, MN 55060-0448  
Phone 800.4WENGER (493.6437)  
Fax 507.455.4258  
Customer Service 800.887.7145

### WENGER CORPORATION

CANADIAN REPRESENTATIVE OFFICE  
Phone 800.268.0148

### WORLDWIDE

Phone 507.455.4100  
Fax 507.774.8576

### WEB SITE

[wengercorp.com](http://wengercorp.com)