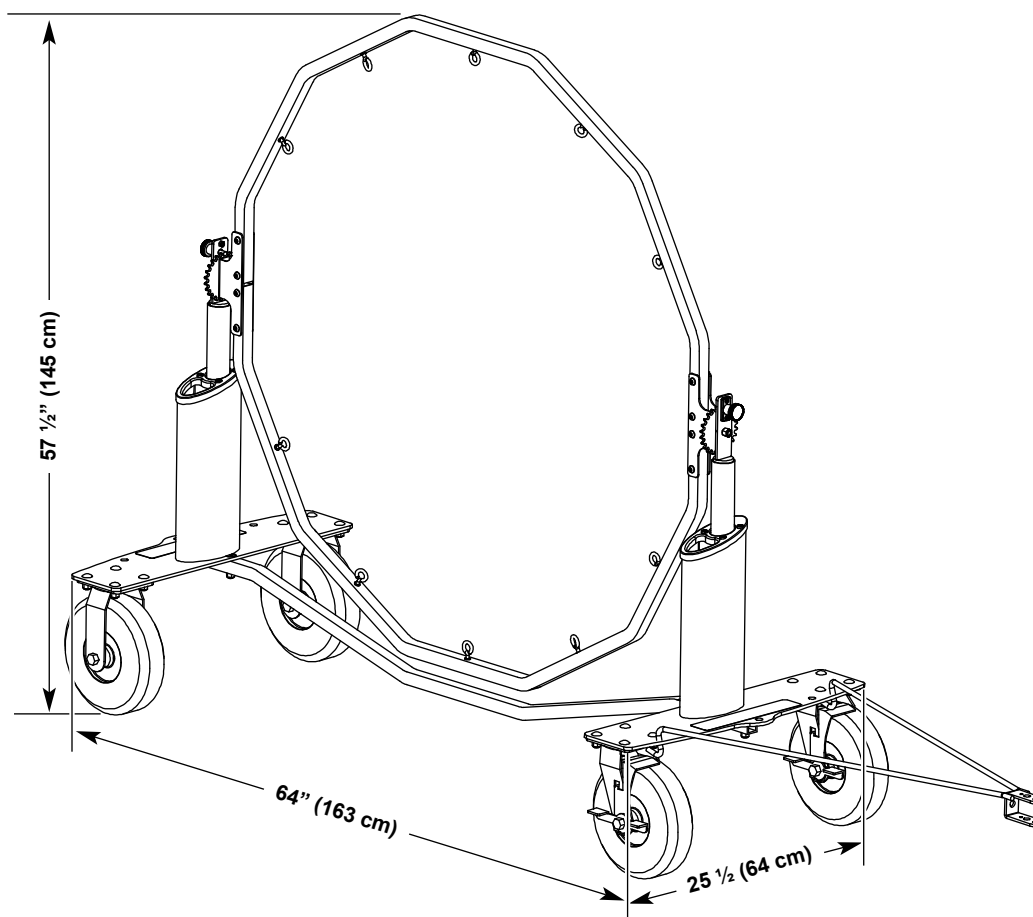

OnBoard® Bass Drum/Gong Cart

- 210A013 OnBoard Bass Drum/Gong Cart, 81 lbs. (37 kg).
- Ideal for rolling bass drum or gong onto field for competitions or indoor concerts and rehearsal.
- Designed to fit into trailers, semi-trailers, and trucks.
- Dual-purpose use for both bass drum and gong.
- Elastic suspension system designed to easily hold the weight of a large bass drum or gong up to 40" (101 cm) in diameter.
- Loop tube constructed of 16-gauge, 1" (2.5 cm) square tubing with steel eyebolts included.
- Drum rotates into performance position in 15-degree increments and locks.
- Fits through 28" (71 cm) door opening.
- Only 25 1/2" wide (64 cm) base for easy playing ability.
- Rolls on two rigid and two swivel 8" (20 cm) pneumatic wheels.
- Tow bar included for pulling by hand or by small garden tractor.
- Mallet storage included on both sides of cart.
- Durable black powder-coat paint finish.
- Dimensions: 25 1/2" wide x 64" long x 57 1/2" high (64 x 163 x 145 cm)
- GREENGUARD Indoor Air Quality Certified® and GREENGUARD Children & SchoolsSM Certified.
- Environmental attributes and LEED compliance for this product can be found at www.wengercorp.com/GREEN or by contacting your Wenger representative.
- Five-year warranty.
- Shipped unassembled.

**WENGER CORPORATION**

555 Park Drive, PO Box 448
 Owatonna, MN 55060-0448
 Phone 800.4WENGER (493.6437)
 Fax 507.455.4258
 Customer Service 800.887.7145

WENGER CORPORATION

CANADIAN REPRESENTATIVE OFFICE
 Phone 800.268.0148

WORLDWIDE

Phone 507.455.4100
 Fax 507.774.8576

WEB SITE

wengercorp.com