

# OnBoard® Cargo Cart

- 210A003 6' (183 cm) OnBoard Cargo Cart, 130 lbs. (59 kg) with hard casters.
- 210A004 6' (183 cm) OnBoard Cargo Cart, 130 lbs. (59 kg) with pneumatic casters.
- Ideal for transporting marching band uniforms, hats, garments, and musical instruments.
- Designed to fit into trailers, semi-trailers and trucks with minimum 6' (183 cm) door height.
- Equipped with removable full-length garment bar and 40 hanger retainer clips.
- Fits through standard 32" (81 cm) door.
- Bottom shelf stores and transports hats, flags (under 6' [183 cm] in length) and instruments.
- Capacities: 35 marching band uniforms on garment bar, 21 hats on bottom shelf.
- Durable black powder-coat paint finish.
- Garment Bar constructed of 12-gauge 1¼" (3.2 cm) round tubing.
- Uprights constructed of 16-gauge 1¼" (3.2 cm) round tubing; include slots for adding additional shelves.
- All-swivel, non-marking solid or pneumatic casters provide easy maneuverability.
- Bottom shelf is constructed of 16-gauge steel construction with black powder-coat paint finish.
- Top of garment bar to top of bottom shelf is 5' 1½" (154 cm).
- GREENGUARD Indoor Air Quality Certified® and GREENGUARD Children & Schools<sup>SM</sup> Certified.
- Environmental attributes and LEED compliance for this product can be found at [www.wengercorp.com/GREEN](http://www.wengercorp.com/GREEN) or by contacting your Wenger representative.
- Five-year warranty.
- Shipped unassembled.

## Optional Accessories

- 210A002 - Additional shelf, 50 lbs (23 kg).
- 210A230 - Hanger Retainer Clip (Bag of 40).

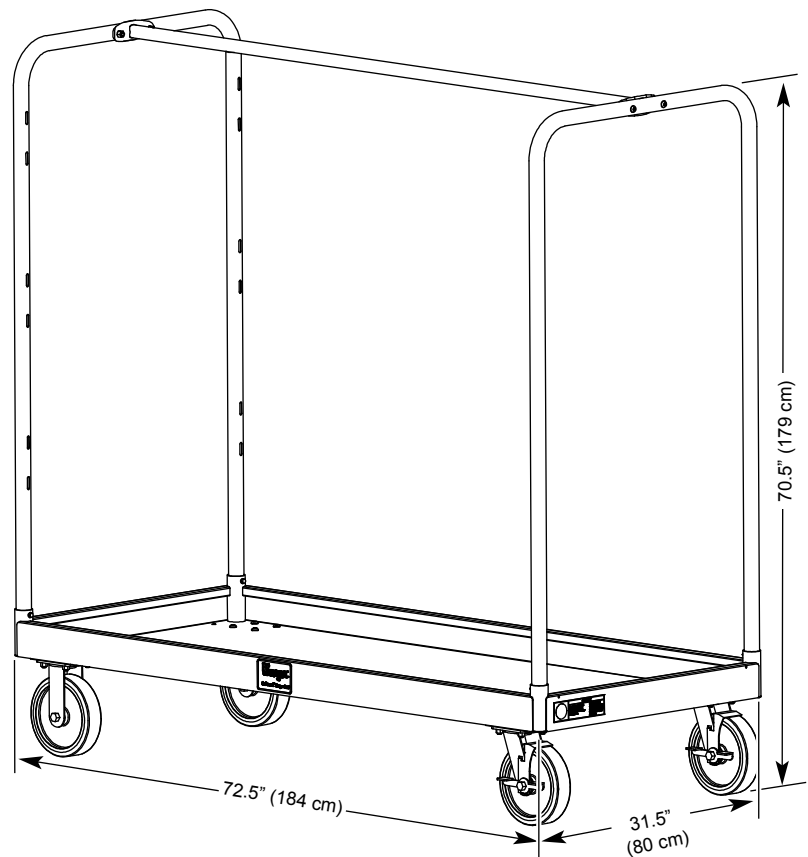

### WENGER CORPORATION

555 Park Drive, PO Box 448  
Owatonna, MN 55060-0448  
Phone 800.4WENGER (493.6437)  
Fax 507.455.4258  
Customer Service 800.887.7145

### WENGER CORPORATION

CANADIAN REPRESENTATIVE OFFICE  
Phone 800.268.0148

### WORLDWIDE

Phone 507.455.4100  
Fax 507.774.8576

### WEB SITE

[wengercorp.com](http://wengercorp.com)