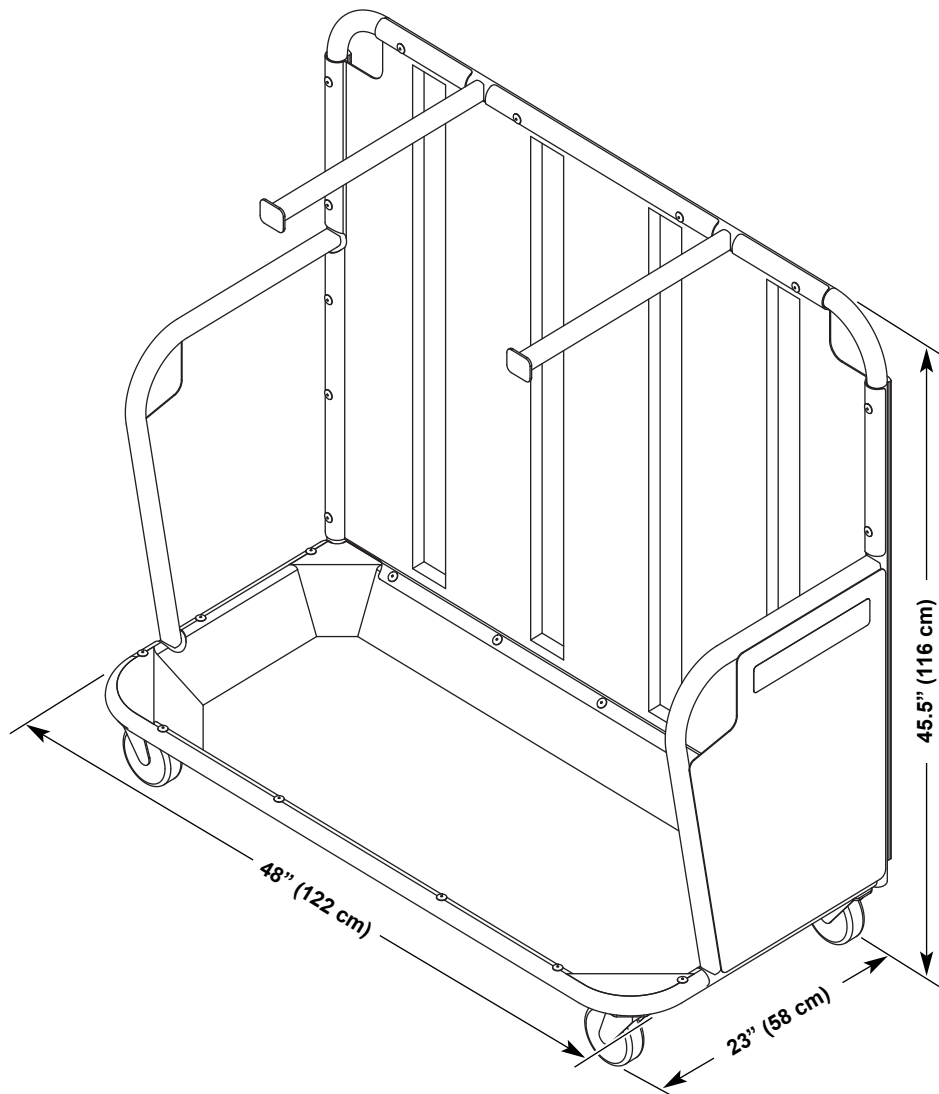

# OnBoard® Uniform Cart

- 210A007 OnBoard Uniform Cart, 56 lbs. (25 kg).
- Ideal for transporting marching band uniforms in the storage compartments of a coach bus.
- Designed to fit into trailers, semi-trailers and trucks.
- Equipped with two 16 gauge, 1¼" (3 cm) round steel tubing with steel end plates for labeling.
- Frame is constructed of 14-gauge 1¼" (3 cm) round tubular steel in black powder-coat paint finish.
- Back and bottom tray constructed of black ABS plastic for superior strength and durability.
- Fits through standard 32" (81 cm) door.
- Includes built-in handholds for tilting and sliding cart into storage compartment - no lifting involved.
- Glides included on back of cart for sliding into compartment.
- Capacity for 24 marching band uniforms.
- 28 hanger retainer clips included with cart.
- All-swivel, non-marring solid polypropylene 4" dia. (10 cm) casters provide easy maneuverability.
- Dimensions: 48" (122 cm) long x 23" (58 cm) deep x 43" (109 cm) high.
- GREENGUARD Indoor Air Quality Certified® and GREENGUARD Children & Schools<sup>SM</sup> Certified.
- Environmental attributes and LEED compliance for this product can be found at [www.wengercorp.com/GREEN](http://www.wengercorp.com/GREEN) or by contacting your Wenger representative.
- Five-year warranty.
- Shipped fully assembled.

**WENGER CORPORATION**

555 Park Drive, PO Box 448  
Owatonna, MN 55060-0448  
Phone 800.4WENGER (493.6437)  
Fax 507.455.4258  
Customer Service 800.887.7145

**WENGER CORPORATION**  
**CANADIAN REPRESENTATIVE OFFICE**  
Phone 800.268.0148

**WORLDWIDE**  
Phone 507.455.4100  
Fax 507.774.8576

**WEB SITE**  
[wengercorp.com](http://wengercorp.com)