

Portable Staging/Seated Riser Guardrail

- Guardrails fit the following Wenger Portable Staging/Seated Riser Systems: Versalite®, Stagehand® and Trouper®.
- Guardrails comply with many building code requirements for loading.
- Guardrails are available with either two crossbars or an infill panel that complies with the 4" (10 cm) sphere requirements of some building codes.
- Guardrails are 42" (107 cm) high and include a chair stop. The second crossbar on the standard rail is located 26" (66 cm) above the stage deck.
- The guardrail has a black powder-coat paint finish and the chair stop has a dark grey powder-coat paint finish.
- Guardrails attach to the staging with a simple clamping device.
- Storage truck available to store and transport the guardrail.
- Environmental attributes and LEED compliance for this product can be found at www.wengercorp.com/GREEN or by contacting your Wenger representative.
- Five-year Warranty.

177B012 45 lbs (20 kg) 8' (244 cm) rail with two crossbars
 177B009 39 lbs (18 kg) 6' (183 cm) rail with two crossbars
 177B004 32 lbs (15 kg) 4' (122 cm) rail with two crossbars
 177B002 29 lbs (13 kg) 3' (91 cm) rail with two crossbars.

177C092 70 lbs (32 kg) 8' (244 cm) rail with 4" (10 cm) sphere panel
 177C089 53 lbs (24 kg) 6' (183 cm) rail with 4" (10 cm) sphere panel
 177C084 35 lbs (16 kg) 4' (122 cm) rail with 4" (10 cm) sphere panel
 177C082 27 lbs (12 kg) 3' (91 cm) rail with 4" (10 cm) sphere panel.

011D800 91 lbs (41 kg) guardrail cart.

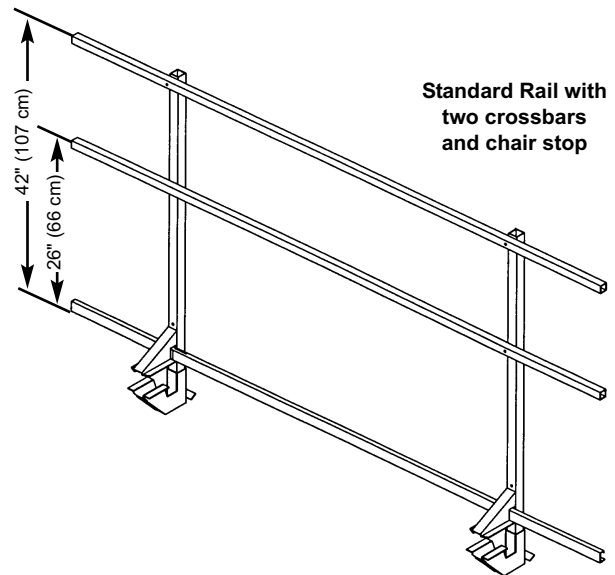

Standard Rail with two crossbars and chair stop

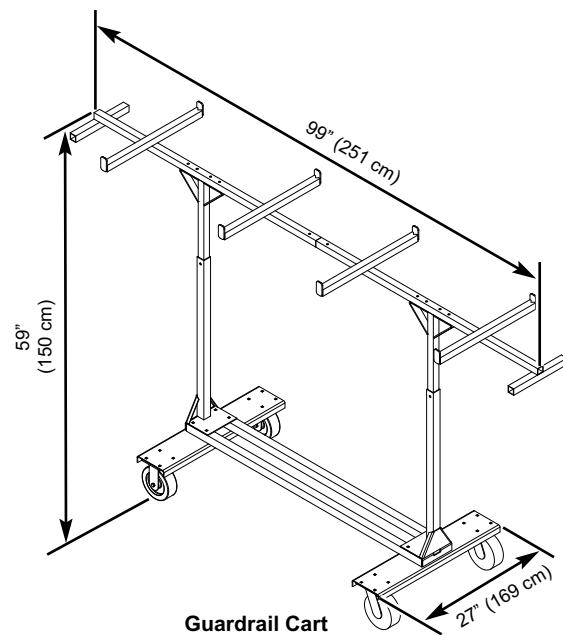

Guardrail Cart

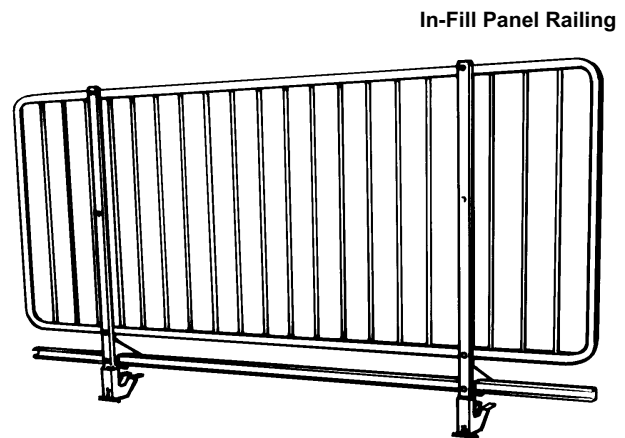

In-Fill Panel Railing

WENGER CORPORATION
 555 Park Drive, PO Box 448
 Owatonna, MN 55060-0448
 Phone 800.4WENGER (493.6437)
 Fax 507.455.4258
 Customer Service 800.887.7145

WENGER CORPORATION
CANADIAN REPRESENTATIVE OFFICE
 Phone 800.268.0148

WORLDWIDE
 Phone 507.455.4100
 Fax 507.774.8576

WEB SITE
wengercorp.com