

Rehearsal Resource Center

- 121C001_ (243 lbs.) (110 kg) Left Curved Unit with Drawer or Stereo Rack Option.
- 121C002_ (243 lbs.) (110 kg) Right Curved Unit with Drawer or Stereo Rack Option.
- 121C003_ (2x 243 lbs) (2x 110 kg) Twin Set - One each Left and Right Curved Unit with Drawer or Stereo Rack Options.
- Top, bottom and interior panels constructed of 1/8" (3 cm) thick thermofused composite wood with polyester laminate finish in graphite.
- Side and interior panels constructed of 3/4" (19 mm) industrial grade particleboard in polyester laminate finish in Wenger standard colors.
- Rack mountable rails and 3 shelves included (Stereo Rack Option only).
- 6-outlet power strip included with 15' (5 m) power cord, rated 15 amp, 120VAC, UL listed (Stereo Rack Option only).
- Top counter space measures 25 1/4" deep x 65 3/8" long (64 x 166 cm).
- Drawer Option includes two 18-gauge steel pull-out drawers 17" wide x 18" deep x 3 1/2" high (43 x 46 x 9 cm) in black finish.
- Includes upper storage compartment.
- Two lockable rear service doors for wiring and cabling access.
- Each unit includes five 4" (10 cm) diameter swivel casters.
- Two wire grommets included in top panel for routing of cables.
- Each unit includes a lockable storage compartment.
- Units will lock together for straight across or wrap-around configuration.
- Rolls through standard 3' (91 cm) doorway.
- Overall dimensions: 28" deep x 39 1/2" high x 65 3/8" long (71 x 100 x 166 cm).
- Overall footprint: Wraparound Configuration: 75 1/2" wide x 75 1/2" deep (192 x 192 cm).
Straight Configuration: 130 3/4" wide x 25 1/2" deep x 39 1/2" high (332 x 65 x 100 cm).
- GREENGUARD Indoor Air Quality Certified® and GREENGUARD Children & SchoolsSM Certified.
- Environmental attributes and LEED compliance for this product can be found at www.wengercorp.com/GREEN or by contacting your Wenger representative.
- Five-year warranty.

Optional Accessories:

Folio Insert:

- 121B105 (26 lbs.) (12 kg) set of two.
- Pass-through slots for handouts, assignments, etc.
- Includes 3 slots at 2" high x 18 3/4" wide (5 x 48 cm).

Locking Security Panels:

- 121B101_ (19 lbs.) (9 kg) Lower door.
- 121B102_ (7 lbs.) (3 kg) Upper door.
- Doors are constructed of 3/4" (19 mm) industrial grade particleboard in polyester laminate finish in Wenger standard colors.

Leg Extensions:

- 121B103 (10 lbs.) (5 kg) set of five.
- Includes 5 tubular steel leg extensions for use with 12" high (30 cm) podiums.
- Adds 6" (15 cm) to height of Rehearsal Resource Center.

Speaker Shelves:

- 121B106_ (13 lbs.) (6 kg) set of two.
- Shelves are 13 5/8" wide x 15 9/32" deep x 3/4" high (35 x 39 x 1.9 cm).
- Fold down flat against unit for storage and transport.
- Shelves are constructed of 3/4" (19 mm) industrial grade particleboard in polyester laminate finish in Wenger standard colors.

Floor Cable Protector:

- 121A107 (2 lbs.) (1 kg).
- PVC flexible protector for cables routed on floor.
- 5' long x 3" wide (152 x 8 cm), pre-slit bottom.

Turntable Drawer

- 147A022 (12 lbs.) (5.4 kg).
- Rack-mountable, slide-out drawer for turntable.
- 17" x 15" (43 x 38 cm).

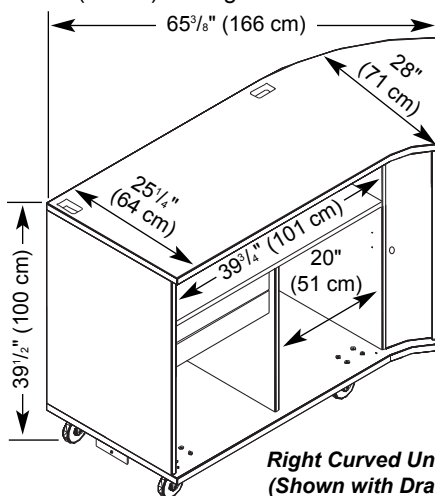

Right Curved Unit Assembly
(Shown with Drawer Option)

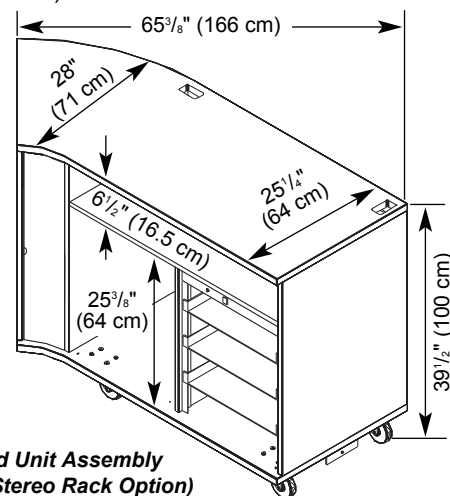

Left Curved Unit Assembly
(Shown with Stereo Rack Option)

WENGER CORPORATION
555 Park Drive, PO Box 448
Owatonna, MN 55060-0448
Phone 800.4WENGER (493.6437)
Fax 507.455.4258
Customer Service 800.887.7145

WENGER CORPORATION
CANADIAN REPRESENTATIVE OFFICE
Phone 800.268.0148

WORLDWIDE
Phone 507.455.4100
Fax 507.774.8576

WEB SITE
wengercorp.com