

Stage Boxes

- 029A105 Black, 24" x 24" x 18" (61 x 61 x 46 cm), 32 lbs (14.5 kg)
- 029A104 Black, 18" x 12" x 16" (46 x 31 x 41 cm), 16 lbs (7.25 kg)
- 029A103 Black, 16" x 12" x 8" (41 x 31 x 21 cm), 8 lbs (3.6 kg)
- 029A098 3-Pack Set, black (54 lbs) (24.5 kg).
- Boxes are sized to mimic basic furniture items and correlate with Wenger staging and flipFORMS® units.
- Rotationally molded linear low-density polyethylene provides durability and longevity.
- Shell has skid resistant texture molded into surface for added safety and sure-footedness.
- Molded thru-handles for easy transportation by one person.
- One open end allows for boxes to be nested compactly for storage or to be used as a transportation crate.
- Protruding feet nest in recessed pockets to allow boxes to stack securely.
- Rubber feet prevent box from moving/slipping on smooth surfaces.
- Patented connection design allows for quick and secure side-to-side, side-to-top, or top-to-top connection.
- Environmental attributes and LEED compliance for this product can be found at www.wengercorp.com/GREEN \ or by contacting your Wenger representative.
- Five-year warranty.
- Patented.

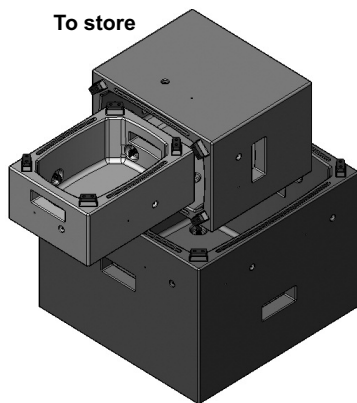

Storage Requirements (L x W x H)
 1 Set Nested: 24" x 24" x 18" (61 x 61 x 46 cm)
 2 Sets Nested: 24" x 24" x 35" (61 x 61 x 89 cm)

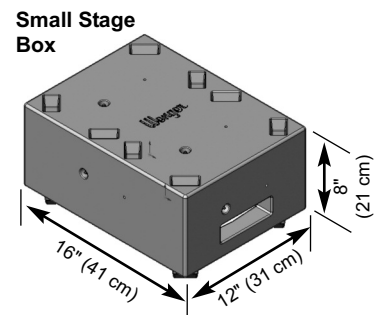
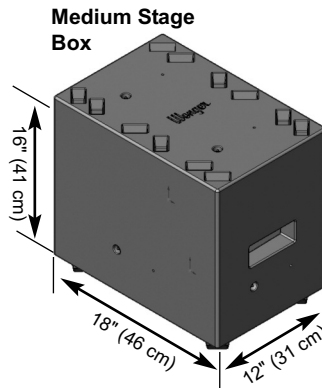
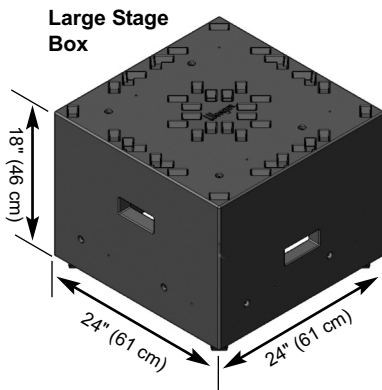
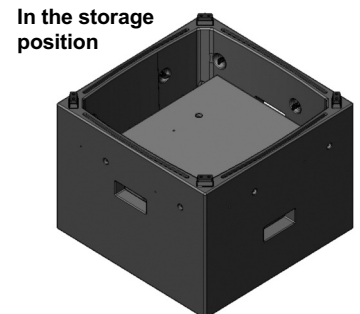
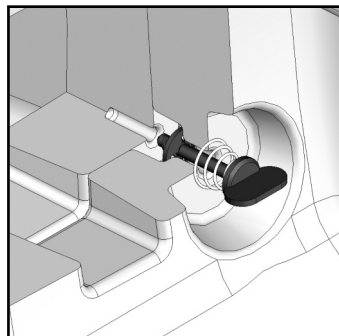

WENGER CORPORATION
 555 Park Drive, PO Box 448
 Owatonna, MN 55060-0448
 Phone 800.4WENGER (493.6437)
 Fax 507.455.4258
 Customer Service 800.887.7145

WENGER CORPORATION
CANADIAN REPRESENTATIVE OFFICE
 Phone 800.268.0148

WORLDWIDE
 Phone 507.455.4100
 Fax 507.774.8576

WEB SITE
wengercorp.com