

Stereo Workstation

- 147G520_ 235 lbs. (107 kg).
- Cabinet is 42" wide x 24" deep x 44½" high (107 x 61 x 113 cm).
- Cabinet is industrial grade composite wood with PVC edging.
- Top has lockable roll top available in two color options:
 - Maple color when Maple, Oyster, Pebble, or Fusion Maple laminate color combinations are selected or
 - Black color when Cherry, Solar Oak, or Evening Tigris laminate color combinations are selected.
- Four 4" (10 cm) swivel casters with rubber cushion mounts to protect delicate electronic equipment.
- Front and back doors are lockable.
- Cabinet has six-outlet, rack-mountable power strip with a master switch and a 15' (38 cm) power cord. The power strip is rated at 15 amps and is UL listed.
- Adjustable shelves are 17½" wide and 16" deep (44 x 41 cm) with a powder-coat paint finish.
- Rack mountable shelves offer flexible storage.
- Rack mounting allows 14 spaces.
- Drawers are 17" wide x 18" deep x 3½" high (43 x 46 x 9 cm) with a powder-coat paint finish.
- Top surface of the cabinet is 40" wide x 19¾" deep (102 x 50 cm), designed to accommodate nearly all standard electronic keyboards.
- GREENGUARD Indoor Air Quality Certified® and GREENGUARD Children & SchoolsSM Certified.
- Environmental attributes and LEED compliance for this product can be found at www.wengercorp.com/GREEN or by contacting your Wenger representative.
- Shipped assembled.
- Ten-year warranty.

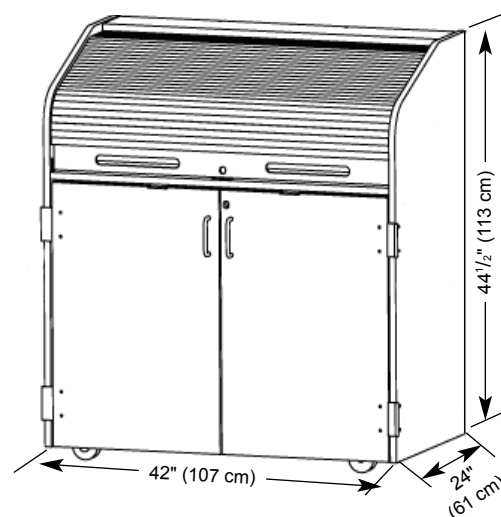

Optional Accessories

Speaker Shelves

- 121B106_ 6 lbs. (2.7 kg).
- Shelves are 13⅞" wide x 15⅞" deep x ¾" high (35 x 39 x 2 cm). Shelves can hold up to 200 lbs (91 kg).
- Mounted on cabinet side, shelves fold down when not in use.

Turntable Drawer

- 147A022 12 lbs. (5.4 kg).
- Rack-mountable, slide-out drawer for turntable.
- 17" x 15" (43 x 38 cm).

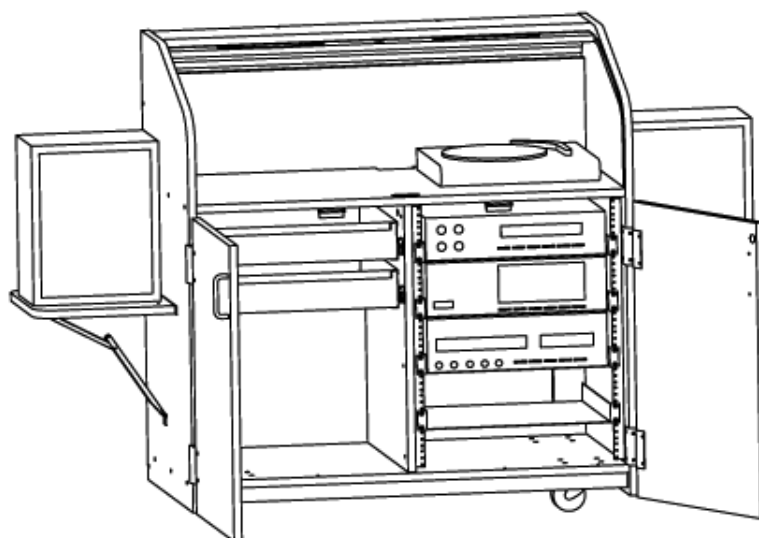

WENGER CORPORATION

555 Park Drive, PO Box 448
Owatonna, MN 55060-0448
Phone 800.4WENGER (493.6437)
Fax 507.455.4258
Customer Service 800.887.7145

WENGER CORPORATION

CANADIAN REPRESENTATIVE OFFICE
Phone 800.268.0148

WORLDWIDE

Phone 507.455.4100
Fax 507.774.8576

WEB SITE

wengercorp.com