

Stringed Instrument Rack

- End panels are 3/4" (19 mm) industrial grade composite wood with polyester laminate finish in Wenger standard colors.
- Edging is 1/8" (3 mm) bonded PVC .
- Racks have 2 1/2" (6 cm) swivel casters in brass finish for easy transport.
- GREENGUARD Certified.
- Five-year warranty.
- Assembly required.

Bass and Cello Racks

- Three-unit Bass Rack: 148F003 (68 lbs) (31 kg).
- Four-unit Bass Rack: 148F004 (75 lbs).(34 kg).
- Four-unit Cello Rack: 148F001 (51 lbs).(23 kg).
- Six-unit Cello Rack: 148F002 (61 lbs).(28 kg).
- Lower cross supports are plywood core laminated panels with padded grey upholstery edging to protect instruments.
- Upper cross supports are plywood core laminated panels with plastic molded neck supports to protect instruments.
- Racks have brass bow pegs.
- Holds instruments 1/4 sized and up.

Violin/Viola Rack

- 148F005 (74 lbs) (34 kg).
- Double-tiered rack moves and stores up to 16 instruments.
- Cross supports are plywood core laminated maple panels with PVC bonded edging on top and bottom supports.
- Spacer pegs are solid maple.
- Holds cased instruments 1/4 size and up.

Violin/Viola Rack

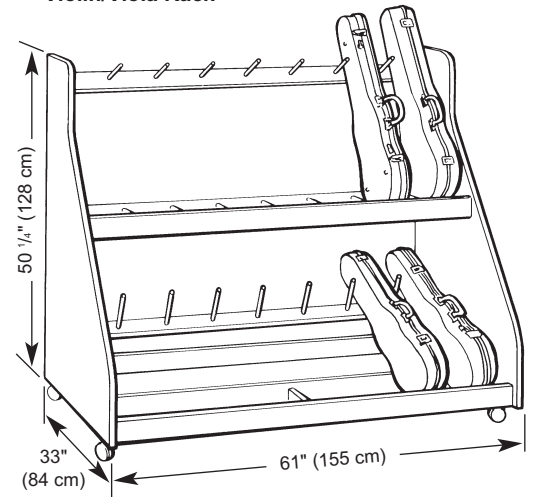

3-Unit Bass Rack

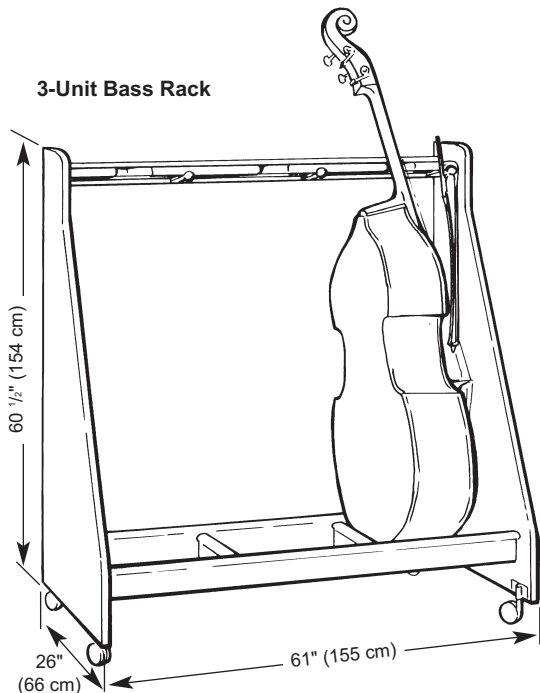

(4-Unit Bass Rack: 80 5/8" (205 cm) wide)

4-Unit Cello Rack

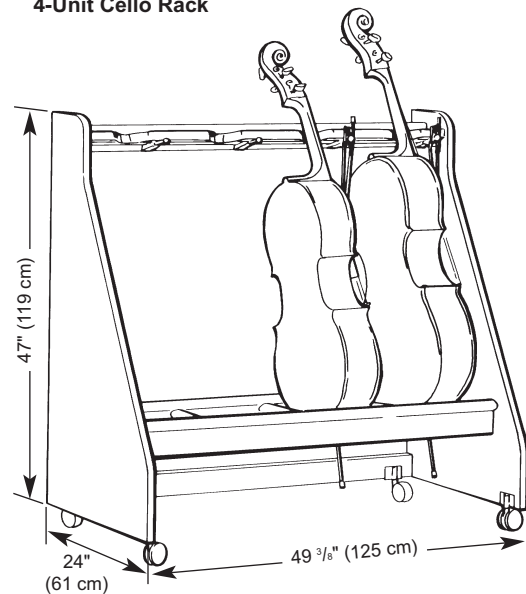

(6-Unit Cello Rack: 73 1/8" (186 cm) wide)

WENGER CORPORATION
 555 Park Drive, PO Box 448
 Owatonna, MN 55060-0448
 Phone 800.4WENGER (493.6437)
 Fax 507.455.4258
 Customer Service 800.887.7145

WENGER CORPORATION
CANADIAN REPRESENTATIVE OFFICE
 Phone 800.268.0148

WENGER CORPORATION
BEIJING REPRESENTATIVE OFFICE
 Phone 0086-10-84972502
 Fax 0086-10-84972575

WORLDWIDE
 Phone 507.455.4100
 Fax 507.774.8576

WEB SITE
wengercorp.com