

Tuba/Sousaphone Mobile Storage Rack

- End panels, yokes, spacers and stiffeners are 3/4" (19 mm) rubberwood with a clear polyurethane finish.
- Cross-member supports are 1" (25 mm) and legs are 1 3/4" (44 mm) rubberwood with a clear polyurethane finish.
- T-molding on yokes is clear 1/8" (3 mm) material.
- Racks have two swivel casters and two swivel casters with brakes for easy maneuverability when needed and stability when it is in a fixed location.
- Top cross-member is vertically adjustable to allow storage of all sizes of Tubas and Sousaphones.
- Lower cross member/support assemblies are adjustable from front to back and between members to provide optimum product support and stability.
- Yokes are horizontally adjustable on the three cross members and across the width of the cross-members to provide optimum product support and stability.
- GREENGUARD Certified.
- 5-year warranty.
- Assembly required.

3-Unit Tuba/Sousaphone Mobile Storage Rack

- Unit is configured to hold:
Three Tubas or
Three Sousaphones
or a combination of three total Tubas and Sousaphones
- 251A003 (107 lbs) (49 kg)

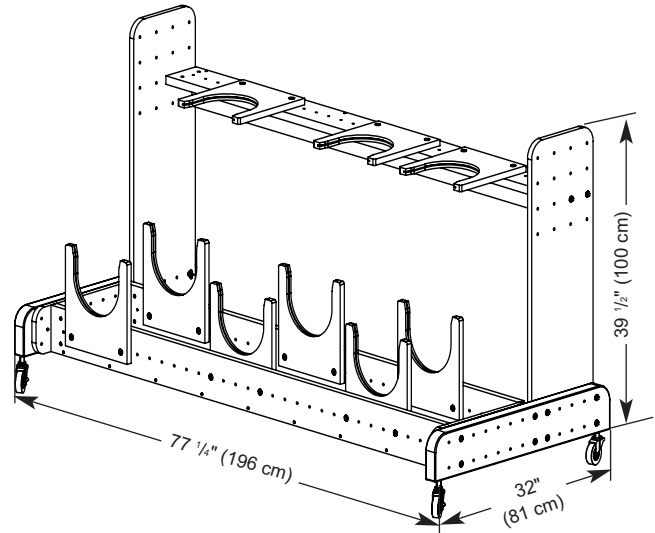

3-Unit Tuba/Sousaphone Mobile Storage Rack

4-Unit Tuba/Sousaphone Mobile Storage Rack

- Unit is configured to hold:
Four Tubas or
Four Sousaphones
or a combination of four total Tubas and Sousaphones
- 251A004 (124 lbs) (56 kg)

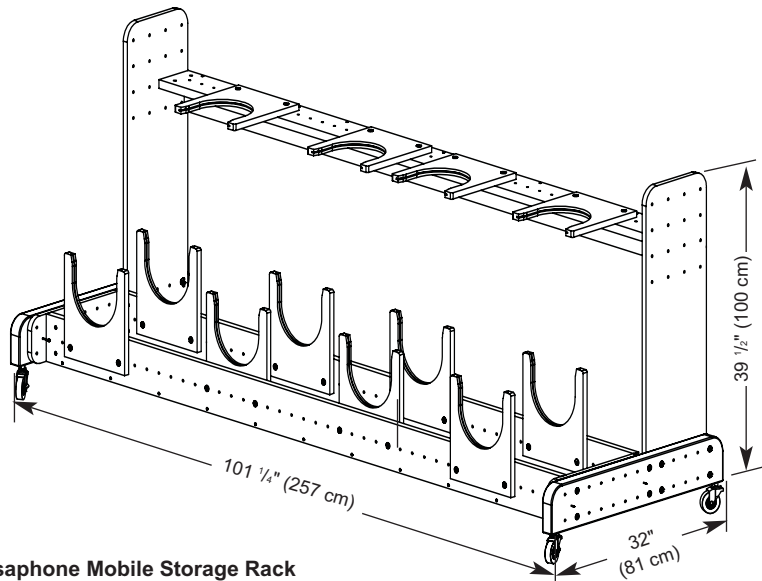

4-Unit Tuba/Sousaphone Mobile Storage Rack

WENGER CORPORATION
555 Park Drive, PO Box 448
Owatonna, MN 55060-0448
Phone 800.4WENGER (493.6437)
Fax 507.455.4258
Customer Service 800.887.7145

WENGER CORPORATION
CANADIAN REPRESENTATIVE OFFICE
Phone 800.268.0148

WENGER CORPORATION
BEIJING REPRESENTATIVE OFFICE
Phone 0086-10-84972502
Fax 0086-10-84972575

WORLDWIDE
Phone 507.455.4100
Fax 507.774.8576

WEB SITE
wengercorp.com