

teacherTAXI® Cart

- 204A001, teacherTAXI Cart, 85 lbs (39 kg).
- Three large shelves: 42" l x 22 ¾" w (107 cm x 58 cm) overall dimensions.
- One piece blow molded polyethylene shelves have a skid resistant texture that is easy to clean.
- Shelf weight load capacity: 100 lbs (45 kg), per shelf.
- Ideal for transporting instrument cases, keyboards, etc.
- Top transport storage rim keeps instrument cases, keyboards, etc. from falling off.
- Ergonomically designed
 - Top work surface at ergonomic height
 - Handle position and design avoids stress
- Fits through standard doorways, hallways and elevators.
- 1½" (3.8 cm) diameter curved steel tubular frame provide strength and attractive design.
- Powder coat paint finish available in eight colors: silver, blue, yellow, red, purple, orange, green, and black .
- Built-in pencil and marker tray on all shelves.
- Center shelf adjusts in seven positions and can be removed.
- Includes cupholders (set of two): one large and one small (large 3½" i.d.; small 2¾" i.d.)
- Water resistant.
- Five-year warranty.
- Shipped assembled.

Optional Accessories:

- Lockable storage drawer for laptop computers, purses, etc:
Inside dimension: 24½" l x 11" w x 6¾" d (62 cm x 28 cm x 17 cm)
Overall dimension: 26 l x 13 w x 7" d (66 cm x 33 cm x 18 cm)
- Pullout surface for teaching or laptop use: surface dimension 12" d x 19½" w (30 cm x 50 cm)
- Power strip is UL approved: 15 amp/6 outlet/10' (3 m) cord.
- Bins available in blue and clear colors.
 - Small; 15" l x 6" w x 6" H (38 cm x 15 cm x 15 cm)
 - Small divided; 15" l x 8½" w x 6" H (38 cm x 21 cm x 15 cm)
 - Medium; 15" l x 12" w x 6" H (38 cm x 30 cm x 15 cm)
 - Medium divided; 15" l x 12" w x 6" H (38 cm x 30 cm x 15 cm)
 - Flat; 15¾" l x 12½" w x 3" H (40 cm x 32 cm x 8 cm)
 - Large with lid (clear only); 16" l x 11" w x 6" H (41 cm x 28 cm x 15 cm)

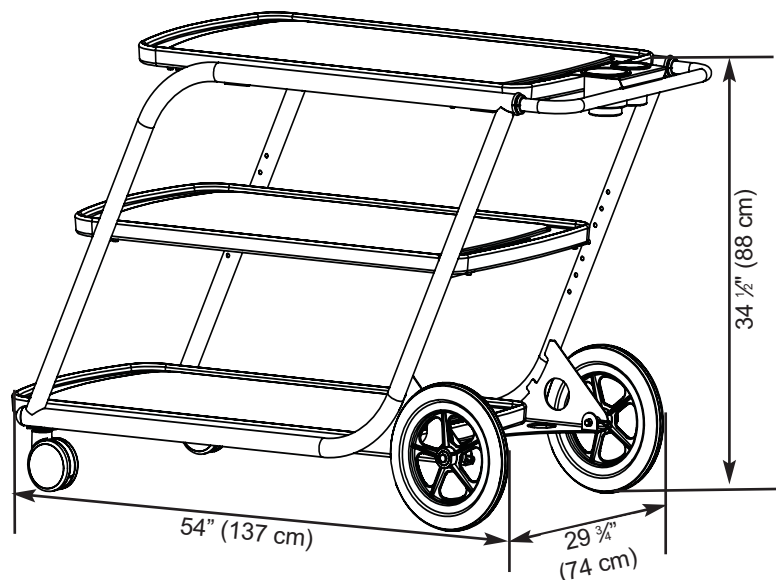

WENGER CORPORATION
555 Park Drive, PO Box 448
Owatonna, MN 55060-0448
Phone 800.4WENGER (493.6437)
Fax 507.455.4258
Customer Service 800.887.7145

WENGER CORPORATION
CANADIAN REPRESENTATIVE OFFICE
Phone 800.268.0148

WENGER CORPORATION
BEIJING REPRESENTATIVE OFFICE
Phone 0086-10-84972502
Fax 0086-10-84972575

WORLDWIDE
Phone 507.455.4100
Fax 507.774.8576

WEB SITE
wengercorp.com