

Contents

Important User Information	2	Light Fixture Operation	17
Safety Precautions	3	Lieto LED Light Fixture Electrical Connection.....	17
Diva Acoustical Shell Set Up	4	Troubleshooting.....	17
General Information	4	Adjustment and Aiming	18
Ceiling Panel Performance Angles	5	Schematics	19
Ceiling Panel Storage Position	6	LED Ceiling Light Electrical Schematic	19
Placing Ceiling Panels into Performance Position	7	Maintenance	20
Changing the Ceiling Panel Performance Angle	9	Towers	20
Tower Set Up	10	Ceiling Panels	20
Moving Towers from Storage	10	Ceiling Lights	20
Tower Performance Position Set Up	14		
Tower Wing Panel Doors	16		

Visit the Diva Acoustical Shell web page at wengercorp.com for more information.

Note: Please read and understand these instructions before using or setting up.

Note: If you need additional information, contact Wenger Corporation using the information below.

Important User Information

General

Copyright © 2021 by Wenger Corporation

All rights reserved. No part of the contents of this manual may be reproduced, copied, or transmitted in any form or by any means including graphic, electronic, or mechanical methods or photocopying, recording, or information storage and retrieval systems without the written permission of the publisher, unless it is for the purchaser's personal use.

Printed and bound in the United States of America.

The information in this manual is subject to change without notice and does not represent a commitment on the part of Wenger Corporation. Wenger Corporation does not assume any responsibility for any errors that may appear in these instructions.

In no event will Wenger Corporation be liable for technical or editorial omissions made herein, nor for direct, indirect, special, incidental, or consequential damages resulting from the use or defect of these instructions. The manufacturer reserves the right to change this product at any time.

The information in this document is not intended to cover all possible conditions and situations that might occur. The end user must exercise caution and common sense when assembling or installing Wenger Corporation products. If any questions or problems arise, call the Wenger Corporation at (800) 4WENGER (493-6437) or +1-507-455-4100 worldwide.

Manufacturer

The Diva® Acoustical Shell is manufactured by:

Wenger Corporation, 555 Park Drive, Owatonna, MN 55060
(800) 4WENGER (493-6437) • +1 (507) 455-4100, wengercorp.com

Intended Use

- The Diva Acoustical Shell is intended for indoor use only and is not intended for outdoor use.
- Never expose the Diva Acoustical Shell components to wind, humidity, or wet conditions.
- This product is intended to be assembled only as described in these instructions.

Installation

- The Diva Acoustical Shell installation and use must comply with local regulations and codes.
- All personnel (including all temporary workers) installing or maintaining the Diva Acoustical Shell must read and understand these and other related installation instructions.

Warranty

This product is guaranteed free of defects in materials and workmanship for five full years from date of shipment. A full warranty statement is available upon request.

Safety Precautions

Throughout this document you may find cautions and warnings which are defined as follows:

- **WARNING:** Failure to follow the instruction could result in serious injury or damage to property.
- **CAUTION:** Failure to follow the instruction could result in minor injury or damage to property.

Read all of these safety instructions before using the equipment.

⚠ WARNING

Make sure that anyone working with the Diva Acoustical Shell has read and understands these instructions.

⚠ WARNING

Failure to comply with Warnings and Cautions in this document can result in damage to property or serious injury.

⚠ WARNING

Always observe and comply with the Warnings and Cautions posted on the system equipment.

Diva Acoustical Shell Set Up

General Information

The Diva Acoustical Shell can be used for a variety of performance groups such as orchestra performance, single performance recitals, etc. Tower and ceiling panel arrangements can be easily changed.

The number of towers and ceiling panels used, how they overlap, and the performance angles can be adjusted for different effects. Some towers have one or two doors for easy stage access.

Refer to the Wenger drawings for the initial set up.

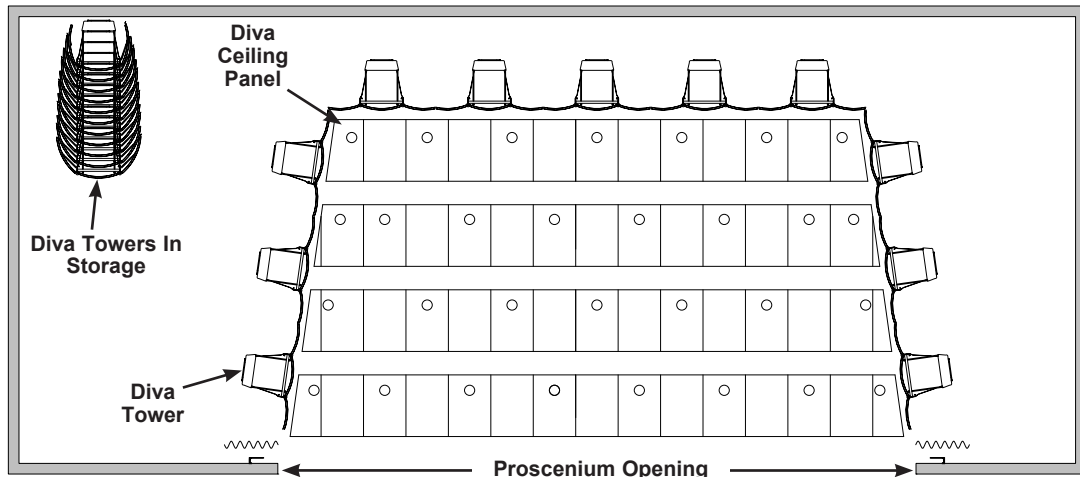

Typical Diva Acoustical Shell Plan View

⚠ WARNING
Never walk or stand on suspended ceiling panels or climb on towers.

⚠ WARNING
Never climb on, mount or hang other equipment from a ceiling panel, rigging or tower without consulting Wenger customer service.

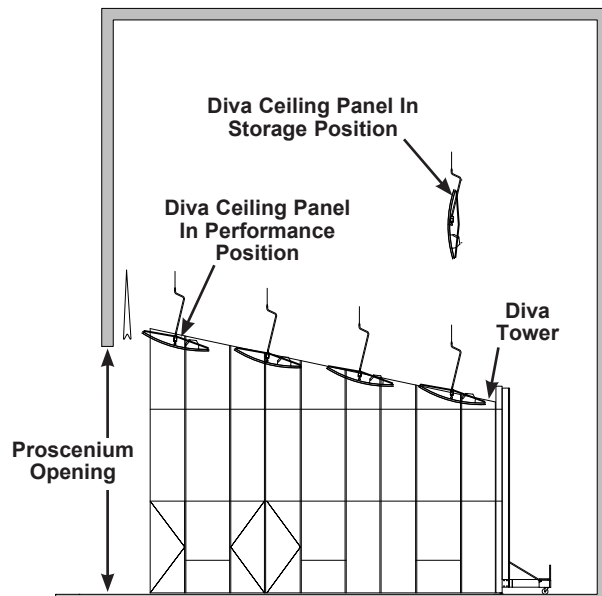

Typical Diva Acoustical Shell Elevation View

Diva Acoustical Shell Set Up (continued)

General Information (continued)

- Towers are stored in a nested position off-stage with wing panels folded.
- Ceiling panel rows are rotated into the vertical position and stored in the loft area.

The sequence for setting up the Diva Acoustical Shell is as follows.

1. Lower the ceiling panels first.
 - a. Place the ceiling panels in a position where the panels can be rotated from the storage position to the performance position, then, lift the ceiling panel rows high enough to move towers across the stage.

Note: Time can be saved if tower positions are marked on the stage floor.

- b. Move the towers with a wheeled mover or an air transporter to the performance position and open the wing panels to the performance position.
- c. If the ceiling panel rows have tapered ends, lower each row to a position slightly below the top of the adjacent side towers.
- d. If the side tower has a tapered top and the edge of the ceiling panel row extends outside of the tower, lower the ceiling panel row to a position 4" to 6" (102 to 152 mm) above the tower.

Ceiling Panel Performance Angles

Ceiling panel performance angles can be adjusted to achieve different acoustic effects. Refer to the illustrations below.

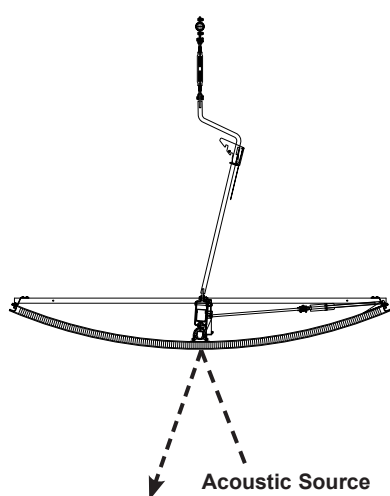

Performance angles that are horizontal will return more acoustic energy to the performers on the stage.

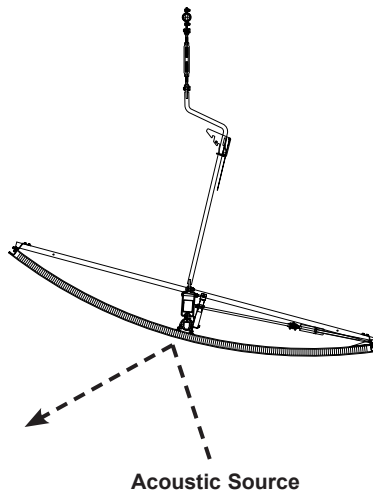

Performance angles that are steeper will return more acoustic energy toward the auditorium area.

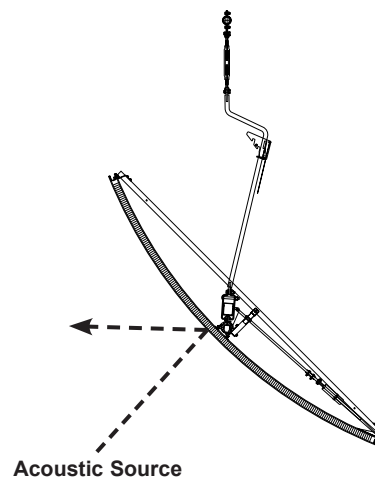

Diva Acoustical Shell Set Up (continued)

Setting Ceiling Panel Position

Ceiling panels are either stored in a vertical storage position or placed into a horizontal performance position. Two or more people should work together to set ceiling panel positions.

- **Performance Position** — The ceiling panel row is rotated until the ceiling stay receiver engages the ceiling stay lever (performance angle) and is lifted to a position above the stage. Refer to the previous illustrations.
- **Storage Position** — The ceiling panel row is rotated vertically until the ceiling panel edge extrusion is engaged with the ceiling panel catch. Refer to the following illustrations.

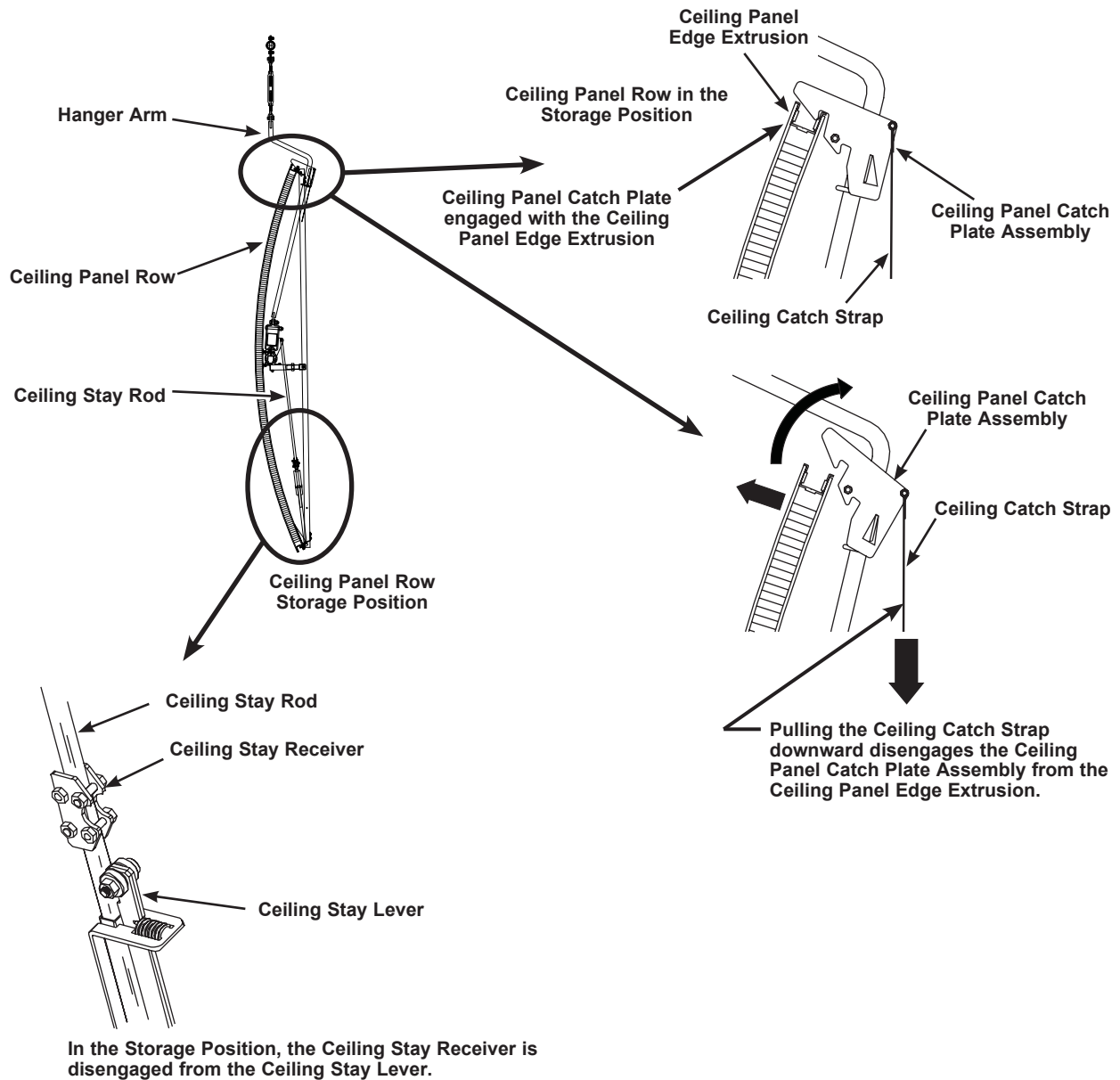

Diva Acoustical Shell Set Up (continued)

Placing Ceiling Panels Into Performance Position

⚠ WARNING

Always clear people and objects from the stage when moving ceiling panels to or from storage.

To move a ceiling panel row into the performance position, work from the downstage side to the upstage side.

1. Clear the stage of all people and objects that might interfere with lowering the ceiling panels.
2. With two or more people working together, lower a ceiling panel row until the upstage edge nearly touches, but does not touch the stage floor (not less than 6" [152 mm] of clearance).

⚠ CAUTION

Do not allow a ceiling panel row upstage edge to touch or strike the stage floor.

3. Mark this position (Low Trim Position) on the hand line at the lock rail.

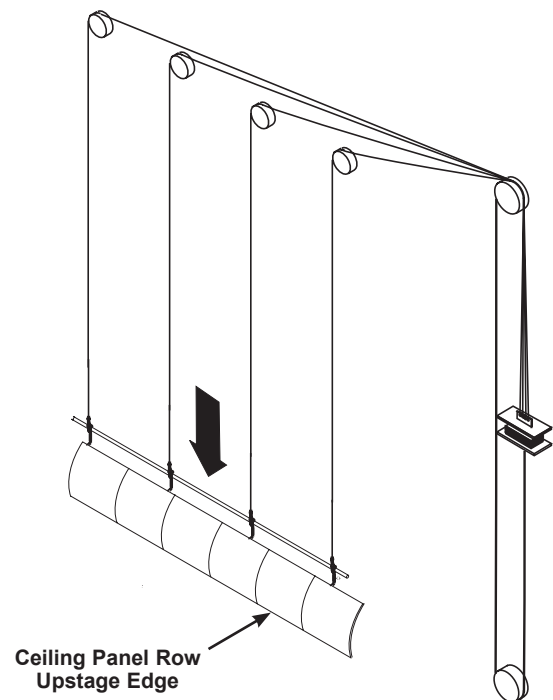

The Ceiling panel row is shown in the storage position and lowered to low trim, not less than 6" [152 mm] from the stage floor.

Diva Acoustical Shell Set Up (continued)

Placing Ceiling Panels Into Performance Position (continued)

4. Rotate the ceiling panels into the performance angle.
 - a. Pull the ceiling catch downward and release the panel from the ceiling panel catch plate assembly.

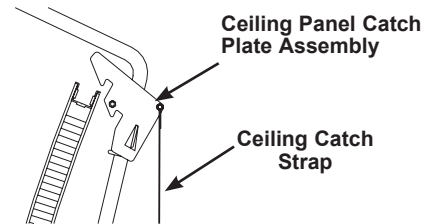

- b. Rotate the downstage edge of the panel row downward until the ceiling stay receiver engages the ceiling stay lever.

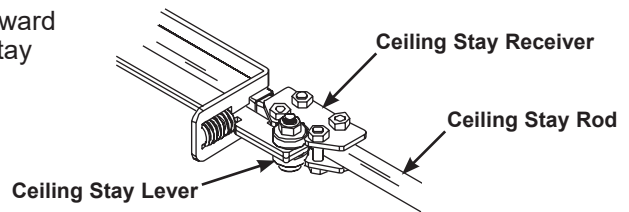

5. Clear the stage and lift the ceiling panel row to the performance position. Make sure that the ceiling panel row does not swing while lifting it.

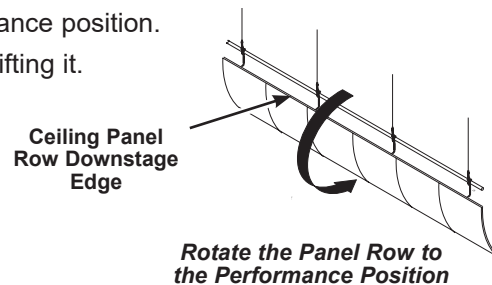

6. Repeat steps 1 through 5 for the other ceiling panel rows.

Diva Acoustical Shell Set Up (continued)

Changing the Ceiling Panel Performance Angle

⚠ WARNING

Always clear people and objects from the stage when moving ceiling panels to or from storage.

1. Clear the stage of all people and objects that might interfere with lowering ceiling panels.

⚠ CAUTION

Do not allow a ceiling panel row upstage edge to touch or strike the stage floor.

2. Lower a ceiling panel row to the low trim position (make sure that the upstage edge does not touch the stage floor has not less than 6" of clearance to the stage floor).
3. With two or more people working together, rotate the ceiling panel into the current performance position.
 - a. Pull the ceiling catch downward and release the panel from the ceiling panel catch plate assembly.
 - b. Rotate the downstage edge of the panel row downward until the ceiling stay receiver engages the ceiling stay lever.
4. Use a pair of 7/16" combination wrenches to loosen all of the hex head screws (4) and lock nuts on the ceiling stay receiver while two people hold the ceiling panel upstage edge.
5. With two people working together grasping the upstage edge, rotate the ceiling panel row slightly above the new performance angle (perhaps five to ten-degrees) making sure that the ceiling stay receiver remains engaged with the ceiling stay lever. Ceiling panel rows are heavier on the upstage side.
6. Use the pair of 7/16" combination wrenches and tighten all of the hex head screws (4) and lock nuts on the ceiling stay receiver while two people hold the ceiling panel upstage edge.
7. Check the performance angle and make any necessary adjustments.

Note: if the performance angle is changed often, mark the positions on the ceiling stay rod.

8. Lift the ceiling panel row to the performance position.
Make sure that the ceiling panel row does not swing while lifting it.

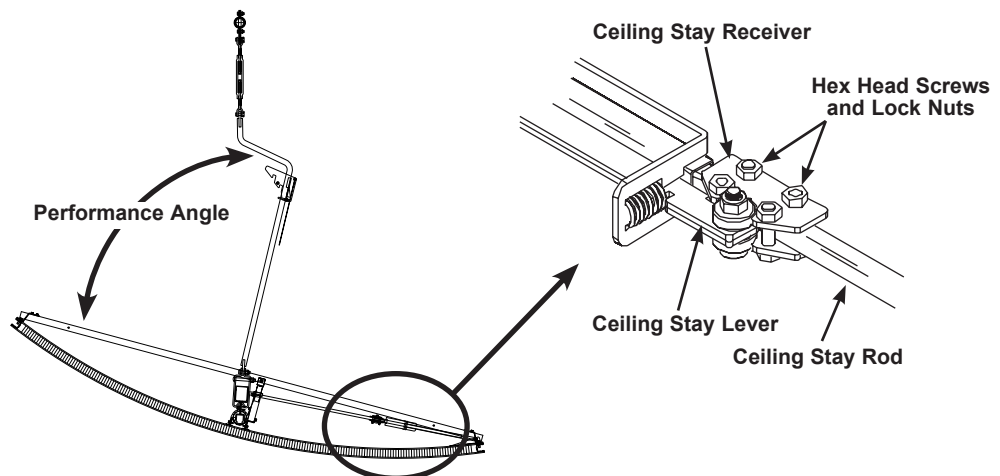

Tower Set Up

Moving Towers From Storage

A separate manual wheeled mover or electric air transporter is required to lift and move the towers.

CAUTION

Never use the wheeled mover or air transporter for any purpose other than to move and position towers.

CAUTION

Never attempt to manually lift or move a tower without using a wheeled mover or air transporter.

1. To move the air transporter when not supporting a tower, tilt the front upward on the rear casters about 10 to 15 degrees.

To move the wheeled mover when not supporting a tower, raise the handle to the upper hook.

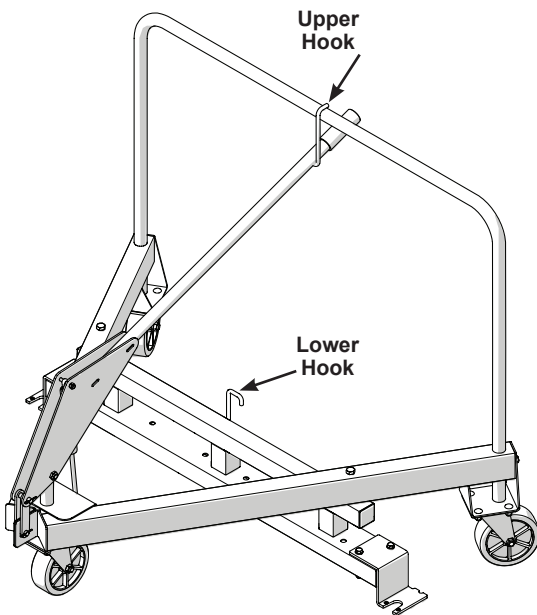

Wheeled Mover

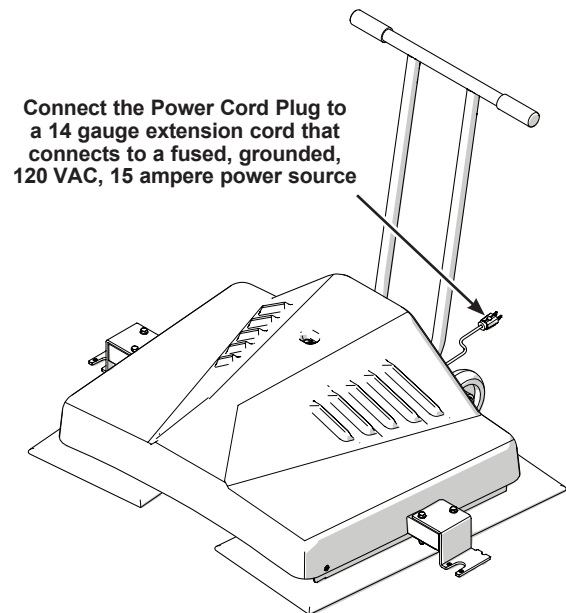

Connect the Power Cord Plug to a 14 gauge extension cord that connects to a fused, grounded, 120 VAC, 15 ampere power source

Air Transporter

Tower Set Up (continued)

Moving Towers From Storage (continued)

2. Position the wheeled mover (shown) or air transporter under the tower with the lifting hooks under the lifting brackets on both sides of the tower.
3. If using an air transporter, connect the power cord to a 14-gauge extension cord that connects to a fused, grounded, 120 VAC, 15 ampere power source.

Be sure that the extension cord is long enough to reach wherever the air transporter will be moved. Prevent cord interference or damage by having another person manage the cord while moving the towers.

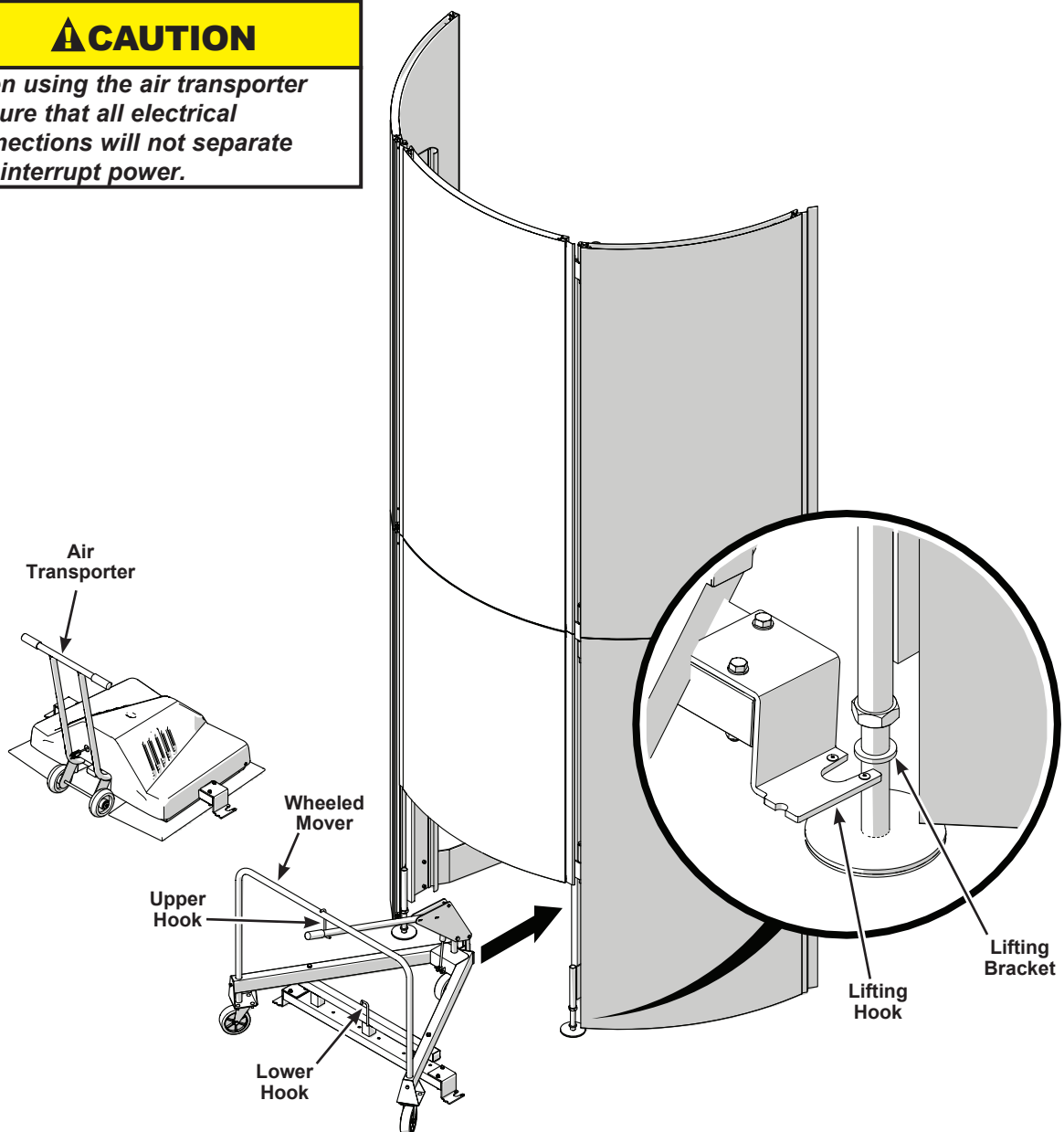
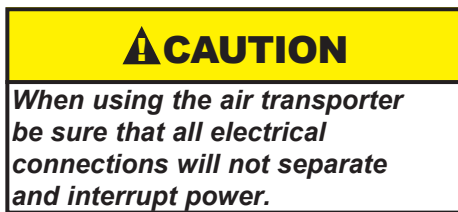

Tower Set Up (continued)

Moving Towers From Storage (continued)

4. Raise the lifting hooks under the lifting brackets by pushing the handle down, under the lower hook on the wheeled mover or by turning on the power switch on the air transporter.

The tower will tilt slightly backward.

5. Slowly move the tower about 5' (1524 mm) from the other towers.

⚠ WARNING

Never move a tower on an inclined surface or ramp.

⚠ WARNING

Always clear people and objects from the stage when moving a tower.

6. Stop moving the tower and check to be sure that the wing panels are locked in the storage position and that the wing doors are locked to the wing panels.

⚠ CAUTION

Always rotate and lock the tower wing panels to the storage position before moving the tower to or from the performance position.

7. With one person pushing the tower and a second person guiding, slowly move (**no faster than 1 foot [0.3 m] per second**) the tower to the performance position. Be careful to not push the tower into any obstructions on the stage floor or above the stage floor (such as ceiling panels, etc.).

⚠ CAUTION

Two or more people must work together when moving a tower. One person must watch for obstructions on the stage and above the stage while a second person pushes the tower.

⚠ CAUTION

Never move a tower faster than 1 foot (0.3 m) per second.

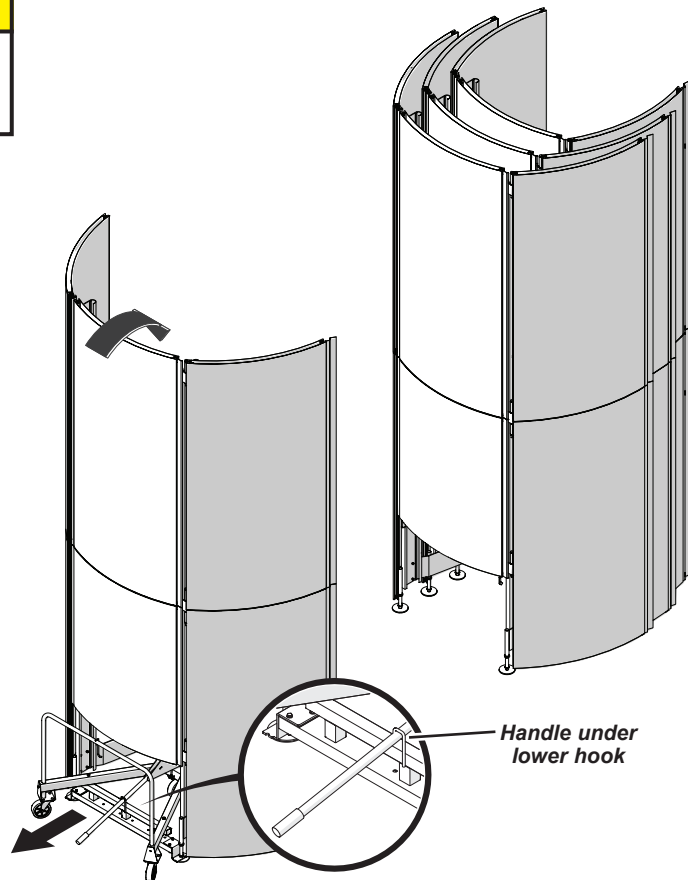

Note: It is best to create permanent marks for the performance positions for all towers before moving the towers from storage.

Tower Set Up (continued)

Moving Towers From Storage (continued)

8. When the tower is in the final location, grip the handle of the wheeled mover firmly and slowly move it from the lower hook to the upper hook.

If using an air transporter, turn off the power switch.

The tower will tilt slightly forward until it rests on the floor.

⚠ CAUTION

Keep a firm grip on the wheeled mover handle when raising or lowering towers. Releasing the handle could cause the tower to drop suddenly.

⚠ CAUTION

A dangerous pinch point develops when lowering a tower to the floor.

9. Remove the wheeled mover or air transporter from the tower.
10. Repeat these steps to move the remaining towers to their performance positions.

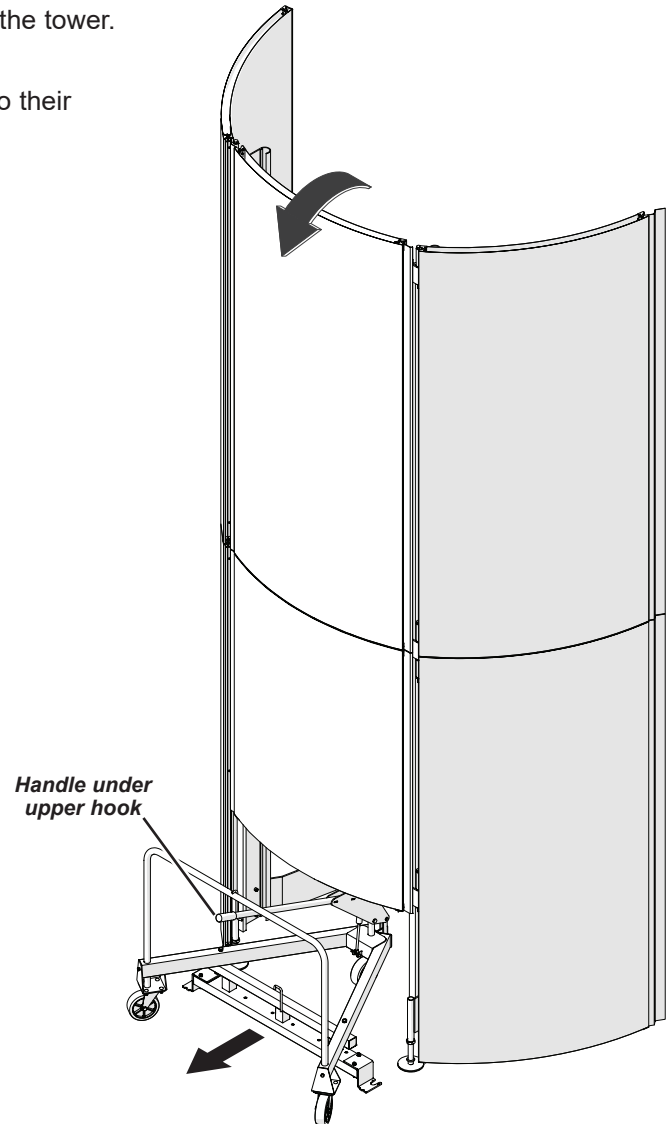

Tower Set Up (continued)

Tower Performance Position Set Up

1. Position the tower wing panels.
 - a. Turn the wing stay lock about one-half turn counterclockwise to release the wing panel.
 - b. Rotate the wing panel to the performance position.
 - c. Lock the wing panel by turning the wing stay lock clockwise until snug.
 - d. Position the opposite wing panel by repeating steps 1a through 1c.
 - e. Place the other tower wing panel into the performance position.
 - f. If necessary, adjust the tower positions using a wheeled mover or air transporter.

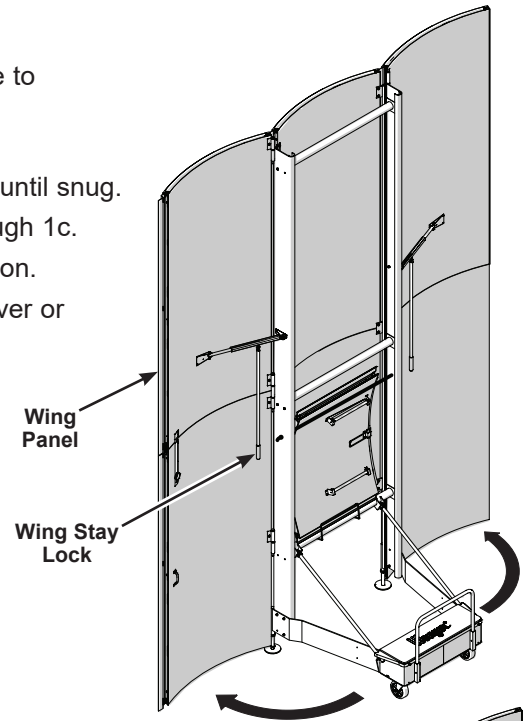

2. Towers should be level and adjacent wing panels should be even.
 - a. Use a 48" (1219 mm) box level or similar tool and check the level of each tower.
 - b. Adjust the leveling pads by using a wrench to turn the adjustment nut as necessary.

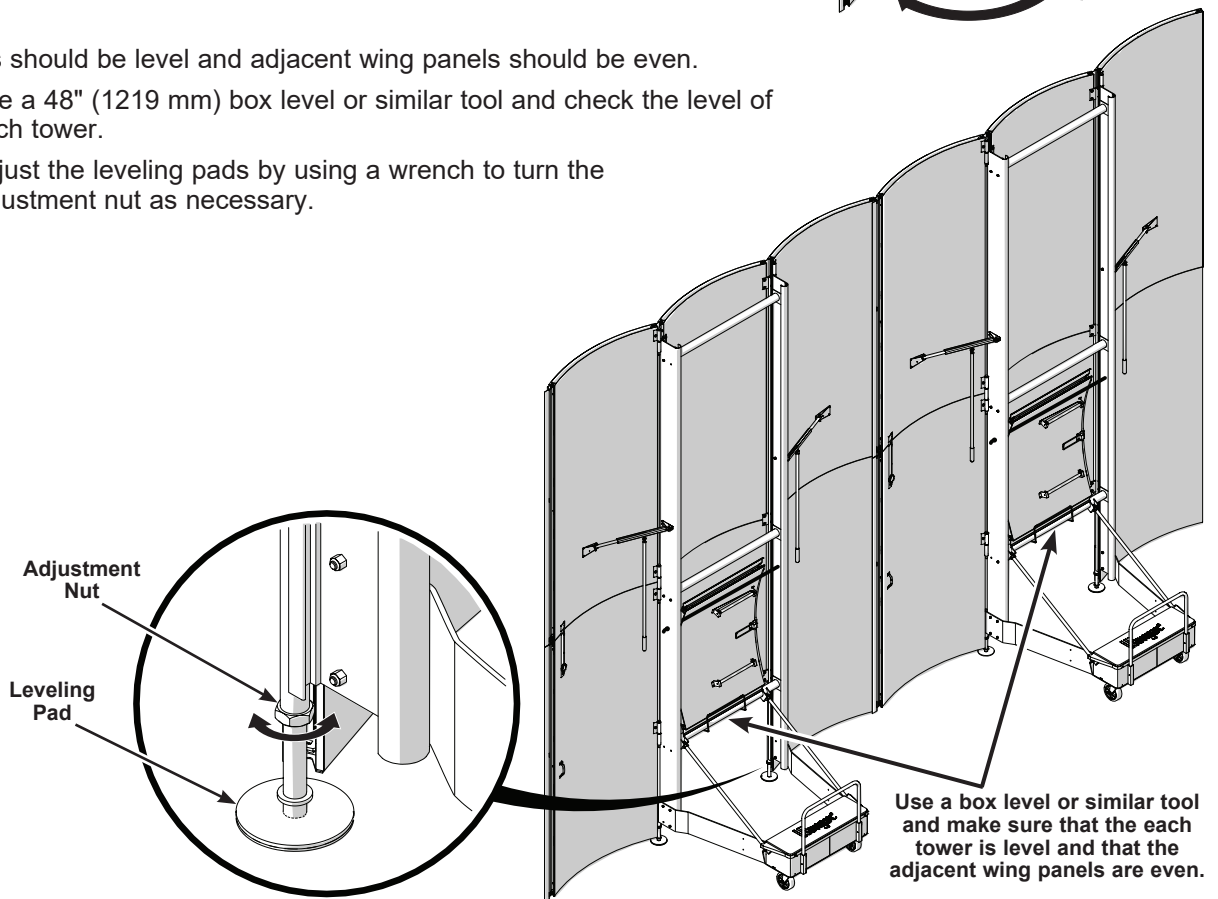

Tower Set Up (continued)

Tower Performance Position Set Up (continued)

3. Install the lower center filler panel to the tower.
 - a. Lift the lower center filler panel away from the back side of the tower and the retention cord.

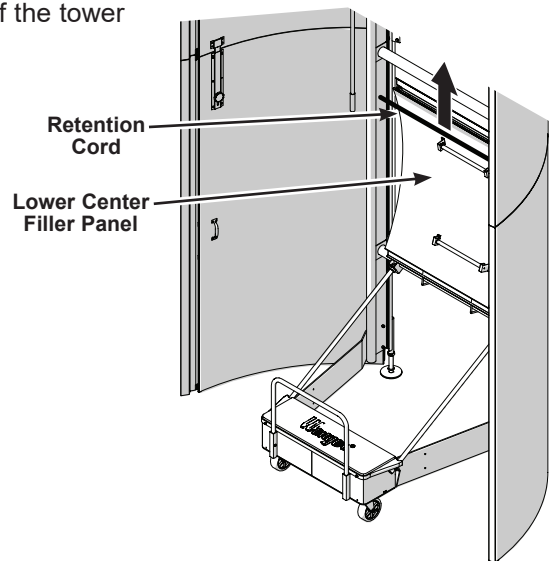

- b. Align the filler panel just below the lower center panel from the front side of the tower.
 - c. Holding the panel handles, place the lower filler panel into position below the lower center panel.

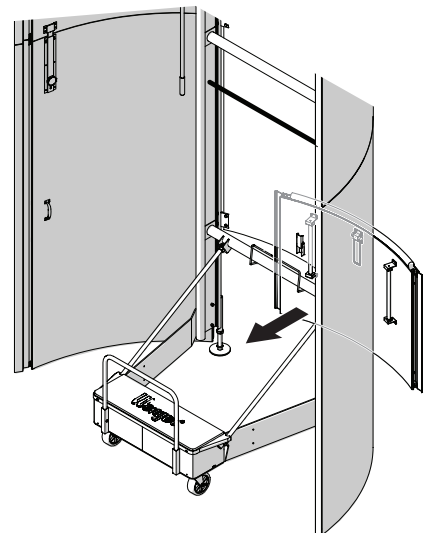

- d. Lock the lower center filler panel to the lower center panel with one person holding the filler panel in place and a second person engaging the hook rods with the locking lever and closing the locking lever.

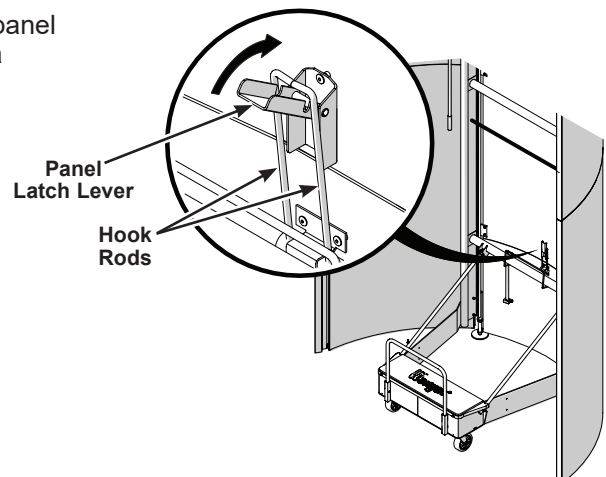

Tower Set Up (continued)

Tower Wing Panel Doors

Wing panels with a door open as follows.

Note: When two doors are adjacent, always open the door without edge trim first.

1. Turn the slide lock knob counterclockwise to release the slide lock slide.
2. Pull the slide lock slide downward to clear the slide lock keeper and turn the slide lock knob clockwise until it is snug.
3. Open the door.

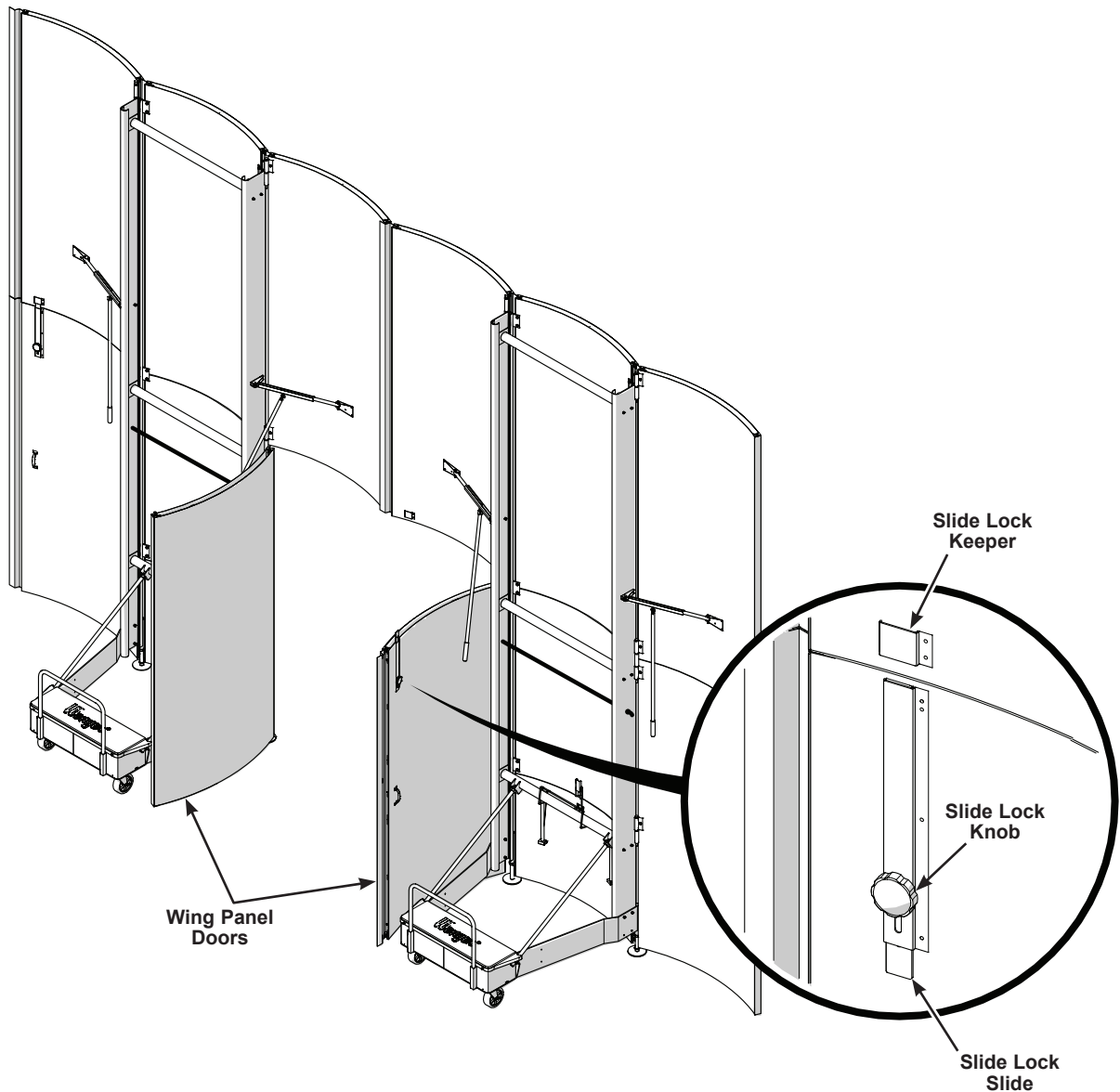

Light Fixture Operation

STOP These procedures detail basic operation of the Lieto™ LED Light Fixture. For more information refer to the Lieto Light Fixture Owner's Manual at wengercorp.com.

Lieto LED Light Fixture Electrical Connection

CAUTION
Do not connect or disconnect the LED PowerCON connector under load.

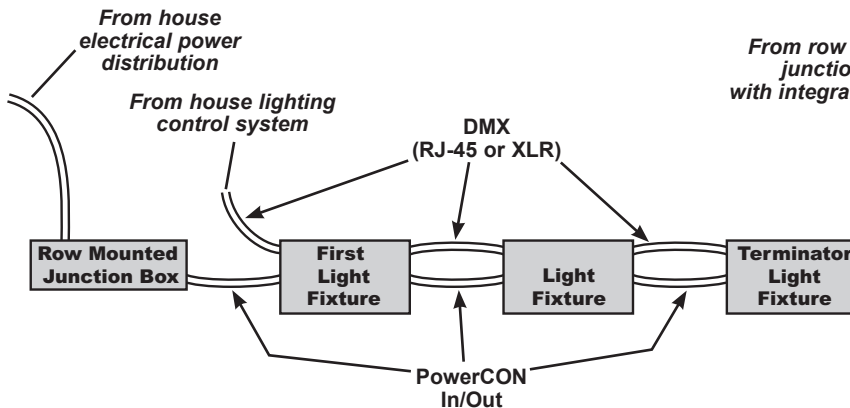

Daisy Chain Multiple LED Lights

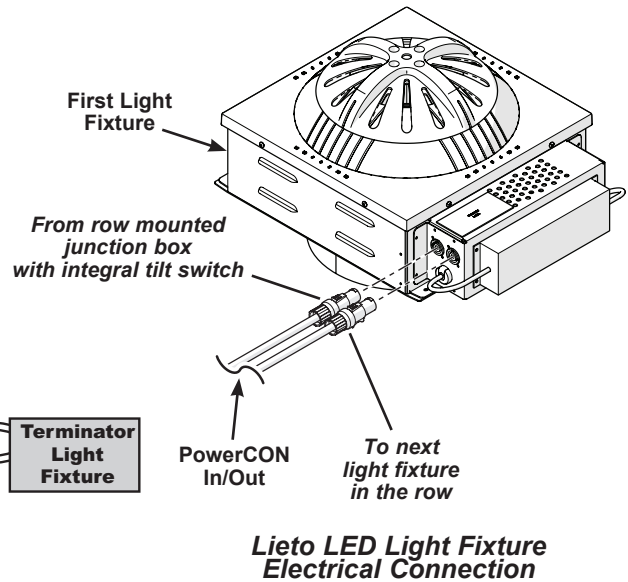

WARNING
Branch circuits that supply power for ceiling panel lights and other accessories must always be designed by an electrical engineer and comply with electrical codes and user requirements.

WARNING
Do not alter the ceiling panel light electrical circuits without consulting the Wenger Corporation.

WARNING
Replace any malfunctioning ceiling panel electrical components only with components with the same specification.

CAUTION
Always disconnect power to the ceiling panel junction box prior to performing any work on the electrical system or components.

Ceiling panels with integral lighting utilize a tilt switch and a low amperage relay circuit to ensure that power is unavailable to the lights when in the storage position. This prevents the lights from being turned on inadvertently.

Troubleshooting

The Lieto LED light fixture will default to “Full-On” when the unit has power but no control signal.

Light Fixture Operation (continued)

Adjustment and Aiming

To adjust the angle and orientation of the LED array, use the adjustment knobs located in the underside of the light fixture.

1. Loosen the adjustment knobs to change the LED array angle and orientation.
2. Use the knobs, to orient the LED array to the desired angle.
3. Tighten the adjustment knobs to secure the LED array in the new position.

CAUTION

***Only tighten the adjustment knobs by hand.
Use of tooling could cause damage.***

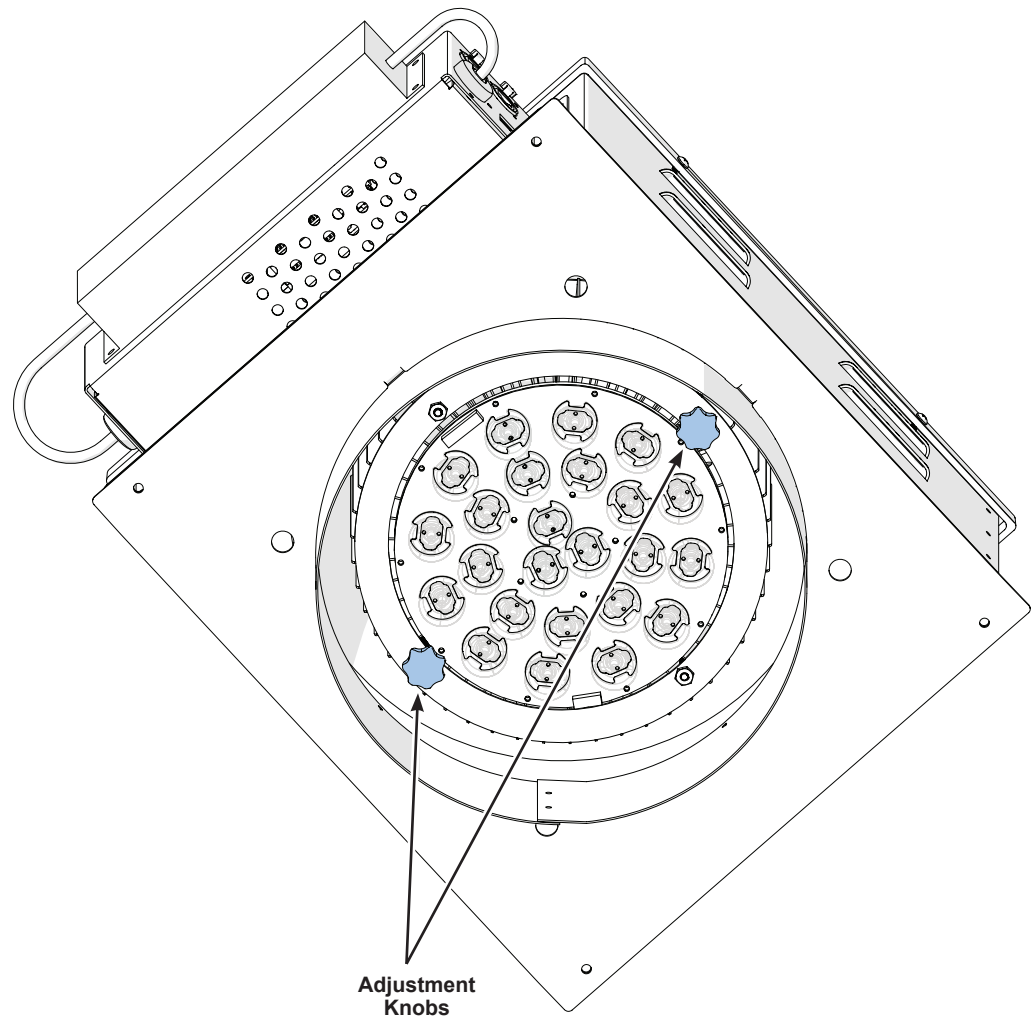

Schematics

Lieto LED Light Fixture Electrical Schematic (Diva® Acoustical Ceiling)

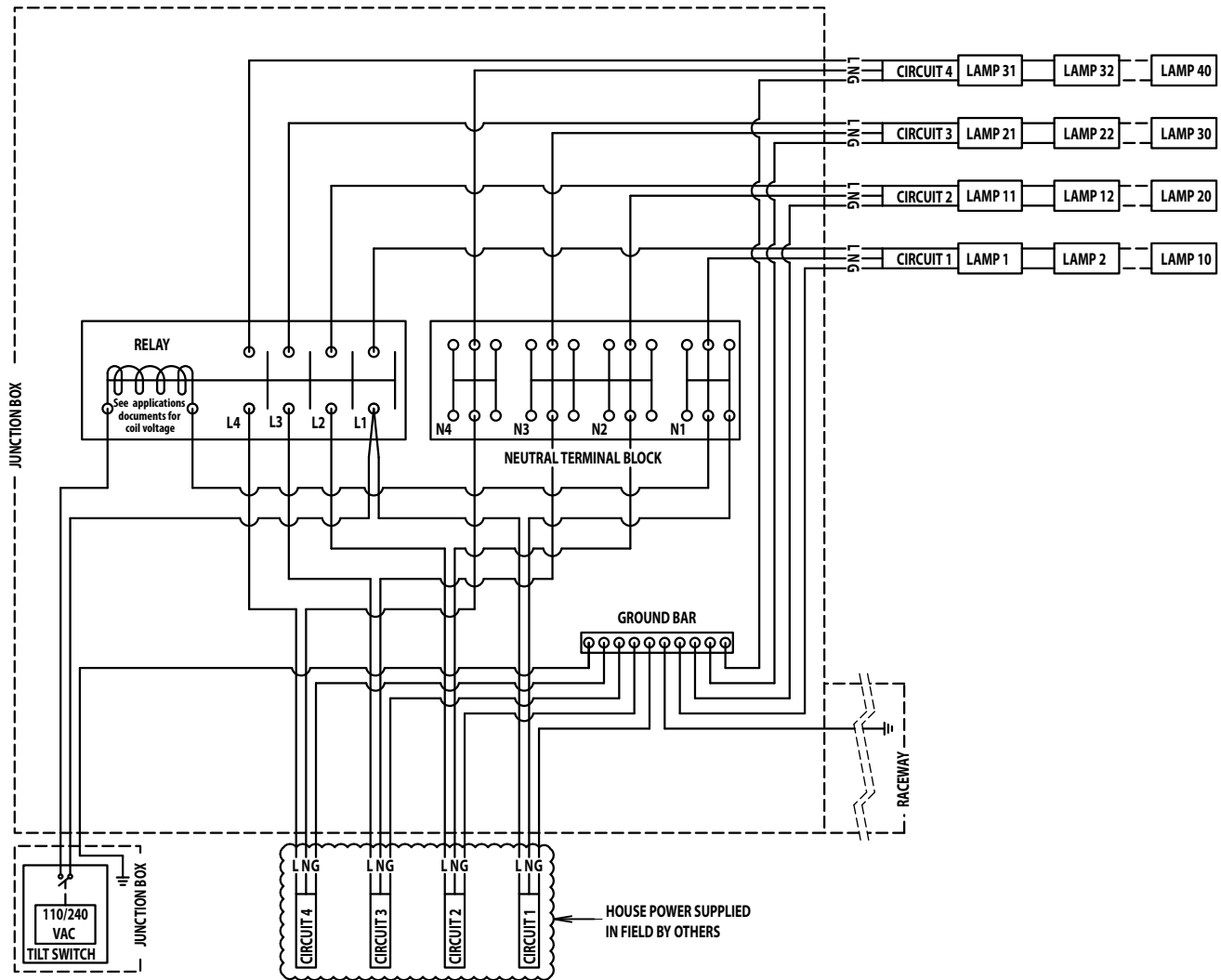

Maintenance

Towers

1. Clean surfaces with a mild, non-abrasive detergent when soiled.
2. Be sure that all fasteners are tight.
3. Replace any damaged part immediately.
4. Lubricate any leveler parts that do not move freely with a general purpose grease.
5. Immediately replace any missing counterweights with Wenger Corporation replacement parts.
6. Be sure that all hinges move freely.
7. Replace any damaged rear frame casters.

Ceiling Panels

1. Clean surfaces with a mild, non-abrasive detergent when soiled.
2. Be sure that all fasteners are tight.
3. Inspect rigging before flying or storing ceiling panels.
4. Be sure that all hanger brackets turn freely on truss assemblies.
Replace parts as necessary.
5. Check ceiling panel performance angles and adjust when necessary.
Be sure that the ceiling panel ceiling stay levers work and move easily.

Ceiling Lights

⚠ WARNING

Replace any malfunctioning ceiling panel electrical components only with components with the same specification.

⚠ WARNING

The light fixture must be disconnected from the site's power supply before any maintenance is performed.

1. Replace burned out lamps with those of the same wattage rating.
2. Be sure that all ceiling light power cord plugs are connected to grounded, twist-lock receptacles in a locked position.
3. Be sure that all power cords are not frayed or under tension when the ceiling panels are deployed or stored.
4. Be sure that the ceiling light tilt switch works correctly before the ceiling panel is moved to a storage position.
5. Periodically remove dust and debris from the surface and lower light diffuser for optimal appearance and performance.