

Showmobile® Mobile Stage and Canopy

Wenger®

Showmobile® is an all-in-one mobile performance system that creates a polished, high-profile performance environment for events of all kinds. The Showmobile features a full-scale, thrust-style stage with a cantilevered canopy and a state-of-the-art acoustical shell finished inside and outside. Set up and operation are simple and fast. When on site, the truck can unhitch and drive away.

- Wall surfaces are weather-resistant, acoustically reflective panels
- Deck surfaces are weather-resistant, slip-resistant Quadriple surface
- Extruded aluminum channels on the roof and canopy form a continuous gutter system for moisture drainage. These channels create a watertight, dust-tight seal during transport.
- An internal hydraulic system with wired remote deploys the stage and canopy which is leveled by jacks
- A 12-volt battery powers the hydraulic system
- A 110 VAC power center connects to an external 120 VAC power source and supplies LED lighting and electrical outlets
- Lockable storage compartments permit packing auxiliary equipment such as power cords, staging accessories, sound equipment, and other necessities
- The roof and canopy can be lowered to the closed position and side doors closed and locked with the stage deck fully deployed. Stage extensions, stairs, decorative skirts, and stage equipment can be left in place, protected from weather and vandals, and ready for the next performance.
- Five-year warranty
- Environmental attributes and LEED compliance for this product can be found at www.wengercorp.com/GREEN or by contacting your Wenger representative

Intended Use

- Showmobile is intended to be set up inside or outside in almost any weather conditions
- Showmobile can be towed at highway speeds on all roads and can be set up on any level surface



Performance Dimensions

Main stage floor	28' x 6' 6" (8.5 m x 2 m)
Hydraulic stage floor	28' x 8' (8.5 m x 2.4 m)
Overall stage depth	14' 6" (4.4 m)
Stage height from ground	3' 6" (1.07 m)
Canopy height at highest setting from stage surface	17' 4" (5.3 m)
Canopy height at highest setting from ground surface	20' 10" (6.4 m)
Upstage canopy height from stage surface	9' 3" (2.8 m)
Overall overhead canopy depth	13' 2" (4 m)

Travel Dimensions

Length including hitch	33' 8" (10 m)
Body length	28' (8.5 m)
Width	8' 5" (2.6 m)
Height	13' 3" (4 m)

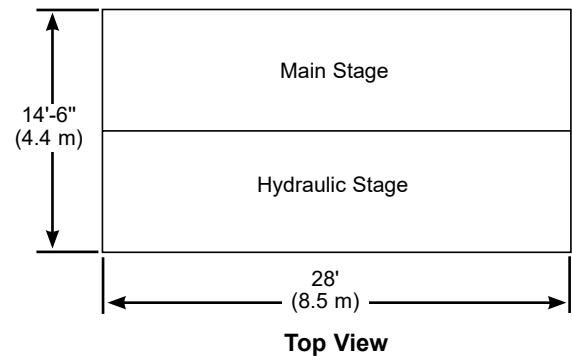
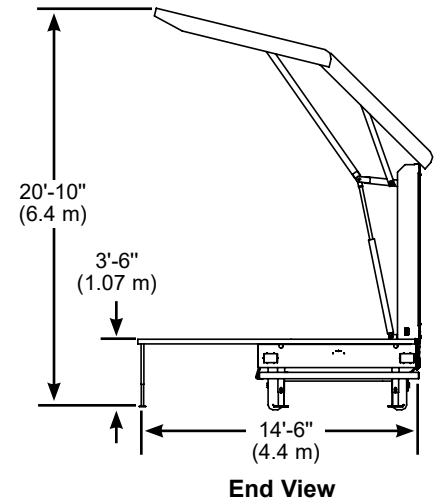
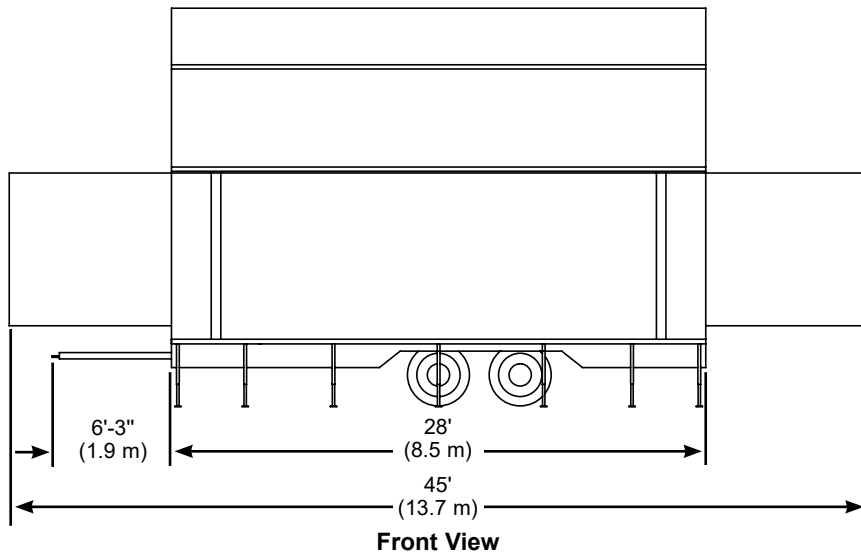

Standard Equipment

- Full 28' (8534 mm) main stage section with no lose stage deck platforms
- Deck surfaces available in black or slip-resistant quadriple surface
- Manual leveling jacks with two removable cranks
- End doors open for easy access and become adjustable side-stage sound reflectors
- Hydraulic canopy and stage deployment with wired remote control module
- Built-in overhead LED lighting
- All trailer indicator lighting is LED (side markers, brakes, license plate)
- Power center with lockable door containing 110-volt load center
- 12-volt battery and charger for the hydraulic system
- Three storage compartments built into the curb side below stage level
- Duplex electrical outlets, two on-stage and one located near the battery for charging
- 110-volt power cable, 50' long (15240 mm)
- Eight on-stage tie-downs with four tie-down straps
- One adjustable all-terrain stairway with handrails
- Pintle hitch coupler
- G-rated tubeless radial tires

Optional Upgrades

These upgrades can only be installed at time of purchase

- Hydraulic leveling reduces set-up time with four hydraulic leveling jacks. Includes wireless remote with auto-level system
- Disability lift on curb side of the Showmobile provides easy stage access for people and equipment.
The 12-volt hydraulic system has a load limit of 600 lb (272.2 kg) with remote control operation and manual backup. ADA compliant.
- Custom graphics with your logo or other designs can be applied with a 3M vinyl adhesive process — many color options

Accessories

These accessories can be added to your Showmobile at any time

- Stage extensions:
Versalite® Platform packages are available to extend your stage from the sides or front.
Stage sizes of 16' x 40', 20' x 40' or 24' x 40' (4877 x 12192 mm, 6096 x 12192 mm or 7315 x 12192 mm) can be created, as well as other configurations you may specify. Includes platforms, adjustable legs and all connectors.
- Stage railings can be added to Versalite stage extensions
- Stage skirting will dress up your Showmobile. Available in 25 colors.
- Stairways can be set up anywhere on the stage perimeter.
- Portable generator. For 110-volt power where electrical service is not available.

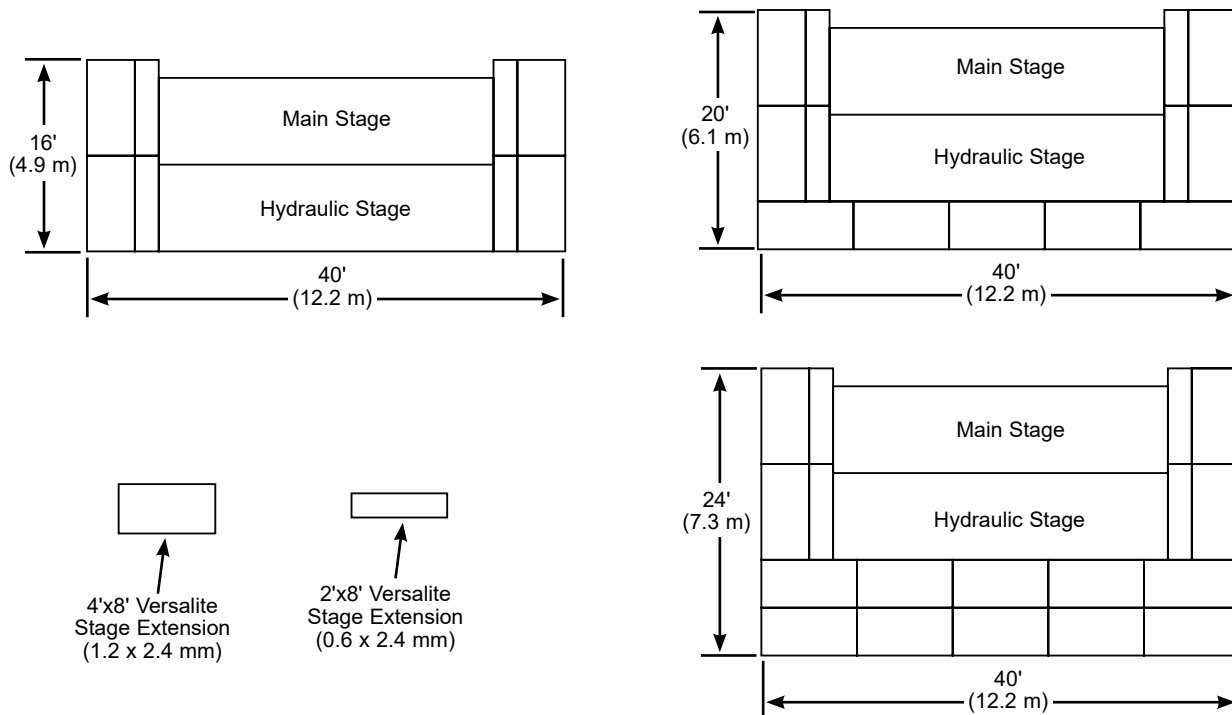

Optional Versalite Stage Extensions

LED Lighting Packages

Utility Package: (Included with standard Showmobile)

- 16 strips of housed, LED lights
 - Total Intensity: 40,000 lumens
 - Color temperature: 4000k

Show lighting upgrade, includes Utility Package lighting plus:

- Wall mounted reprogrammable 5 preset DMX controller (pre-programed for basic function from the factory)
- 5 pin DMX override port for optional external control
- 5 upstage RGB batten downlights
- 8 canopy mounted RGBWA-UV front wash fixtures
 - Total additional intensity: 38,000 lumens

Performance lighting upgrade, includes Utility Package lighting plus:

- Wall mounted reprogrammable 5 preset DMX controller (pre-programed for basic function from the factory)
- 5 pin DMX override port for optional external control
- 5 upstage RGB batten downlights
- 4 high output canopy mounted LED profile fixtures
 - CRI (Color Rendering Index): 97.2
 - Color Temperature: 3200k
 - 50-degree lens
 - Total additional intensity: 57,000 lumens

All fixtures are IP rated for increased longevity.

The Showmobile is fitted with all LED fixturing from the performance lighting to the trailer markers.

All lighting, rigging, and attachment hardware pre-installed at the factory.

Wenger

JRCLANCY

GEARBOSS



© 2020 Wenger Corporation
USA/2020-09

MUSIC EDUCATION AND PERFORMING ARTS

Owatonna Office: Phone 800.4WENGER (493-6437) Worldwide +1.507.455.4100 | Parts & Service 800.887.7145 | wengercorp.com
555 Park Drive, PO Box 448 | Owatonna | MN 55060-0448

Syracuse Office: Phone 800.836.1885 Worldwide +1.315.451.3440 | jrclancy.com | 7041 Interstate Island Road | Syracuse | NY 13209-9713

ATHLETICS Phone 800.493.6437 | email gearboss@wengercorp.com | gearboss.com | 555 Park Drive, PO Box 448 | Owatonna | MN 55060-0448