

Note: Please read and understand the Wood Locker Island Base Bracket Assembly/Owner's Manual before attempting installation, assembly, or use.

Note: Remove all items from the shipping containers and sort the components by type, size, etc. Refer to the illustrations on the following pages. If you need additional information about your Wood Locker Island Base Bracket, contact the Wenger Corporation using the information listed below.

WARRANTY

The GearBoss Wood Locker Island Base Bracket is guaranteed free of defects in materials and workmanship for five full years.

Our guarantee assures you of either a full refund or repair or replacement of the defective materials or workmanship without charge, at the discretion of our Customer Service Department. Just call a Customer Service Representative at 1-800-887-7145 and state the reason you are dissatisfied. If a product return is necessary, your representative will issue a return authorization. This is your sole remedy for breach of this warranty.

Should you have a question or problem with any Wenger product, don't hesitate to call, even if the product is past warranty. It's important to us that all our customers be satisfied.

This is the sole warranty made by Wenger. Wenger disclaims all other warranties, including the warranties of merchantability and fitness for a particular purpose, as well as all liability for incidental, consequential, special, and indirect damage. Wenger liability for direct damages shall be limited to the amount you paid for the product involved. Wenger reserves the right to make product changes without obligation to incorporate such changes into products previously sold.

Some states do not allow the exclusion or limitation of damages or warranties, so the above may not apply to you. This warranty gives you specific legal rights. You may also have other rights which vary from state to state.

PARTS LIST

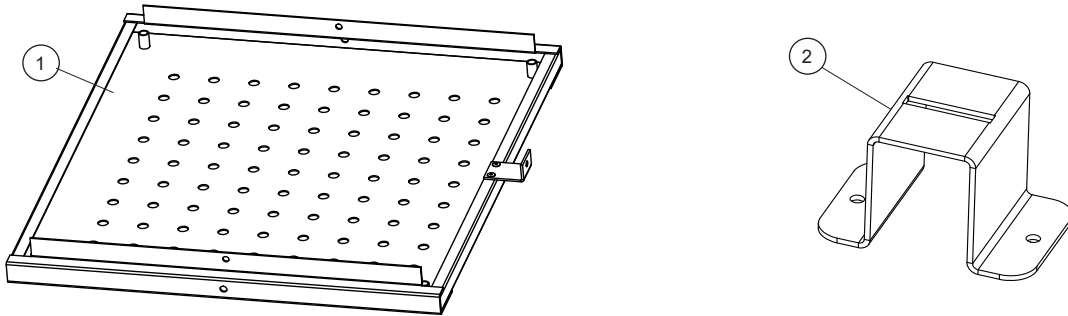

<u>Item</u>	<u>Qty</u>	<u>Description</u>
1		WOOD LOCKER BASE
2	5	ISLAND BASE MOUNT BRACKET

FASTENER GUIDELINES

Because materials and construction of floors can vary, fasteners for attaching the GearBoss locker to the floor are not provided. The installer must choose the appropriate fastener and follow the manufacturer's directions.

Warning: Inferior or improperly installed fasteners could make GearBoss Lockers unstable. Serious injury or damage to property may result.

GearBoss Locker fastener guidelines:

- If the floor is wood construction, attachment should be by sheet metal or lag screws (#10 minimum).
- If the floor is concrete, attachment should be by Concrete screw (Tapcon), or sheet metal screws (#10 minimum) into metal or plastic inserts.

ISLAND BASE BRACKET INSTALLATION

1. Slide the two connecting bases together aligning the brackets on the Wood Locker Base (#1).

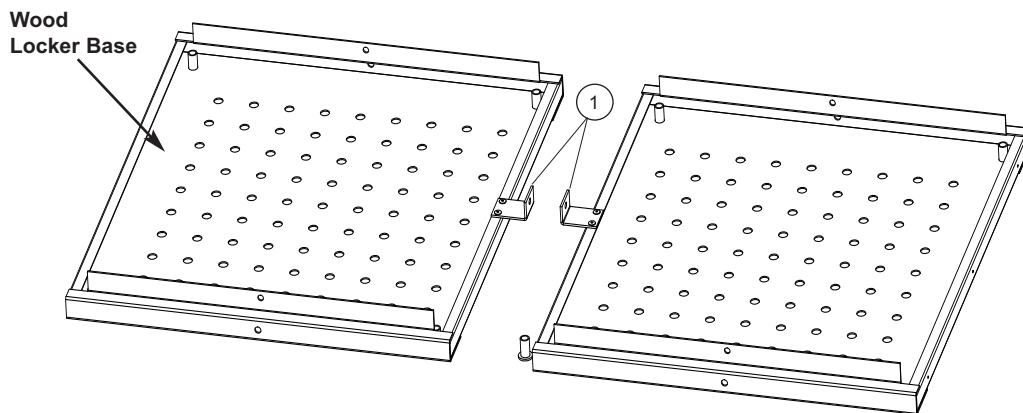

ISLAND BASE BRACKET INSTALLATION

2. Place the Island Base Mount Bracket (#2) onto the brackets on the Wood Locker Base (#1).

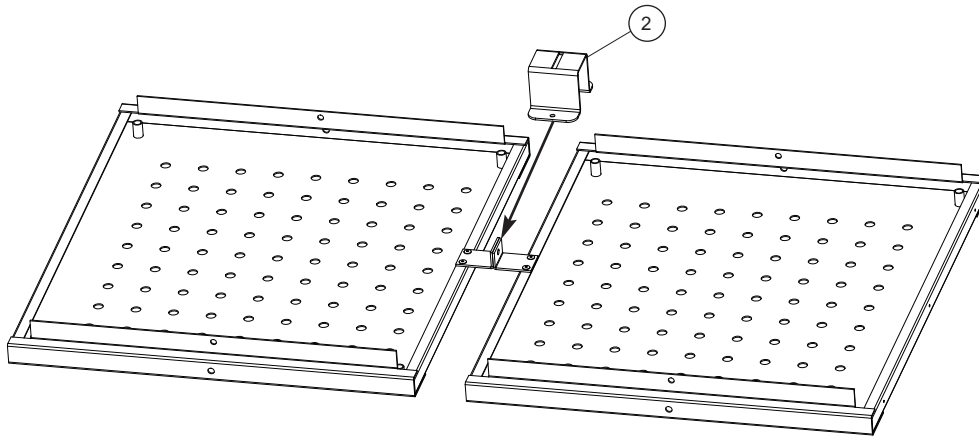

3. Assemble the complete row of Wood Locker Bases (#1). Island Base Mount Bracket (#2) is to be used on every other set of Wood Locker Bases (#1).

Note: First and last set of Wood Locker bases (#1) must have Island Base Mount Brackets (#2).

4. Level all bases.
5. Secure the Island Base Mount Bracket (#2) to the floor using the appropriate fastener for the floor type. See Fastener Guidelines on page 2.

