

# Beam Clamps

- Used for attaching chains or lines to beams for dead hanging or guide wires.
- Includes two 3/8" x 1" (9.5 mm x 25.4 mm) Grade 5 hex bolts with lock nuts, and a 1/4" (6.35 mm) round pin anchor shackle.



Beam Clamp  
015-798

## Dimensions

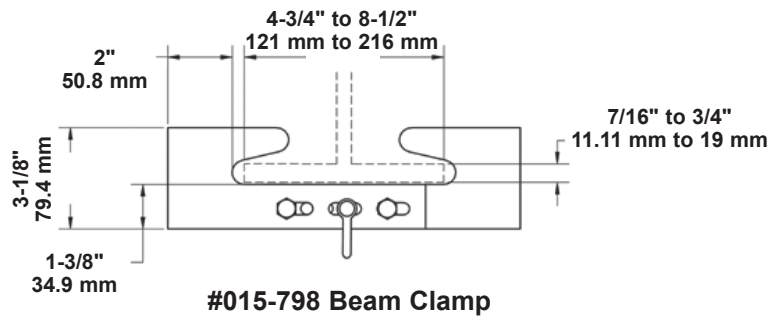
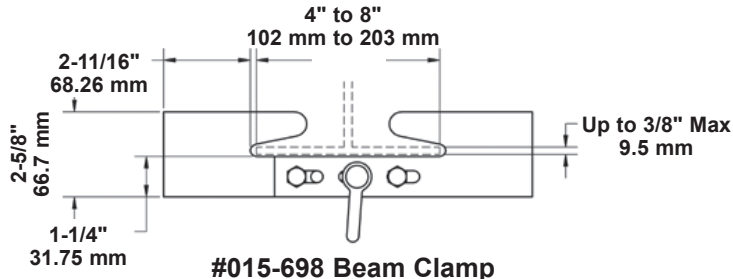

## Order Information

Number	Description	RWL	Weight
015-698	3/8" (9.5 mm) Throat, will grip flanges from 4" to 8" (102 mm to 203 mm)	350 lbs. (159 kg)	2 lbs. (0.9 kg)
015-798	3/4" (19 mm) Throat, will grip flanges from 4-3/4" to 8-1/2" (121 mm to 216 mm)	350 lbs. (159 kg)	2 lbs. (0.9 kg)

**RWL:** RWL is maximum load that can be applied to the beam clamp which is in "like new" condition and has been properly installed, maintained, and operated.



© 2017 Wenger Corporation  
USA/2017-12/W

