

## Contents

<ul style="list-style-type: none"> <li>Important User Information . . . . . 2                             <ul style="list-style-type: none"> <li>General . . . . . 2</li> <li>Manufacturer . . . . . 2</li> <li>Intended Use . . . . . 2</li> <li>Warranty . . . . . 2</li> </ul> </li> <li>Safety Precautions . . . . . 3</li> <li>Counterweight Rigging Systems . . . . . 4                             <ul style="list-style-type: none"> <li>Single Purchase Counterweight Set Description . . . . . 4</li> <li>Double Purchase Counterweight Set Description . . . . . 4</li> <li>Balance . . . . . 5</li> <li>Components . . . . . 5</li> </ul> </li> <li>Counterweight Set Operation . . . . . 7                             <ul style="list-style-type: none"> <li>General Information . . . . . 7</li> <li>General Precautions . . . . . 8</li> <li>Handling Counterweight . . . . . 8</li> </ul> </li> <li>Operation Of Systems With A Loading Bridge . . . . . 9                             <ul style="list-style-type: none"> <li>Attaching Loads To Battens And Loading Arbors . . . . . 9</li> <li>Removing Loads And Unloading Arbors . . . . . 10</li> </ul> </li> <li>Operation Of Systems Without A Loading Bridge . . . . . 11                             <ul style="list-style-type: none"> <li>Attaching Loads To Battens And Loading Arbors . . . . . 11</li> <li>Removing Loads And Unloading Arbors . . . . . 12</li> <li>Operating A Counterweight Set . . . . . 12</li> <li>Working With Out Of Balance Loads . . . . . 13</li> <li>Capstan (Bull Hoist) . . . . . 14</li> <li>Block And Tackle . . . . . 14</li> <li>Using Tag Lines . . . . . 15                                     <ul style="list-style-type: none"> <li>Incremental Loading . . . . . 15</li> <li>Twisting The Hand Line . . . . . 15</li> <li>"Line Lok" Or "Uncle Buddy" . . . . . 16</li> </ul> </li> <li>Human Assisted Hauling . . . . . 16</li> <li>Weight Compensation . . . . . 16</li> </ul> </li> <li>Counterweight Set Maintenance . . . . . 17                             <ul style="list-style-type: none"> <li>General . . . . . 17</li> <li>Everyday Observation . . . . . 17</li> <li>Inspection . . . . . 17</li> <li>Inspection Check List . . . . . 18</li> <li>Testing . . . . . 19</li> <li>Maintenance . . . . . 19</li> </ul> </li> <li>Rope Locks . . . . . 20                             <ul style="list-style-type: none"> <li>General Description . . . . . 20</li> <li>Operation . . . . . 20</li> <li>Inspection . . . . . 21</li> <li>Maintenance . . . . . 21</li> </ul> </li> </ul>	<ul style="list-style-type: none"> <li>Locking Rails . . . . . 22                             <ul style="list-style-type: none"> <li>General Description . . . . . 22</li> <li>Operation . . . . . 22</li> <li>Maintenance . . . . . 22</li> </ul> </li> <li>Counterweight Arbors . . . . . 23                             <ul style="list-style-type: none"> <li>General Description . . . . . 23</li> <li>Inspection . . . . . 24</li> <li>Maintenance . . . . . 24</li> </ul> </li> <li>Arbor Capacity Chart . . . . . 25</li> <li>J-Guide System . . . . . 26                             <ul style="list-style-type: none"> <li>General Description . . . . . 26</li> <li>Inspection . . . . . 26</li> <li>Maintenance . . . . . 26</li> </ul> </li> <li>T-Guide System . . . . . 27                             <ul style="list-style-type: none"> <li>General Description . . . . . 27</li> <li>Inspection . . . . . 27</li> <li>Maintenance . . . . . 27</li> </ul> </li> <li>Index Lights . . . . . 28                             <ul style="list-style-type: none"> <li>General Description . . . . . 28</li> <li>Operation . . . . . 28</li> <li>Maintenance . . . . . 28</li> </ul> </li> <li>Floor Blocks . . . . . 29                             <ul style="list-style-type: none"> <li>General Description . . . . . 29</li> <li>Inspection . . . . . 29</li> <li>Maintenance . . . . . 29</li> </ul> </li> <li>Head And Loft Blocks . . . . . 30                             <ul style="list-style-type: none"> <li>General Description . . . . . 30</li> <li>Inspection . . . . . 30</li> <li>Maintenance . . . . . 30</li> </ul> </li> <li>Mule Blocks . . . . . 31                             <ul style="list-style-type: none"> <li>General Description . . . . . 31</li> <li>Inspection . . . . . 31</li> <li>Maintenance . . . . . 31</li> </ul> </li> <li>Capstan Hoist . . . . . 32                             <ul style="list-style-type: none"> <li>General Description . . . . . 32</li> <li>Installation . . . . . 33</li> <li>Operation . . . . . 34</li> <li>General Precautions . . . . . 35</li> <li>Inspection . . . . . 35</li> <li>Maintenance . . . . . 36</li> </ul> </li> </ul>
---	---

Visit the Counterweight Rigging Systems web page at [jrclancy.com](http://jrclancy.com) for more information.

**Note:** Please read and understand these instructions before starting the assembly or installation.  
**Note:** If you need additional information, contact Wenger Corporation using the information below.

# ***Important User Information***

---

## ***General***

Copyright © 2022 by Wenger Corporation

All rights reserved. No part of the contents of this manual may be reproduced, copied, or transmitted in any form or by any means including graphic, electronic, or mechanical methods or photocopying, recording, or information storage and retrieval systems without the written permission of the publisher, unless it is for the purchaser's personal use.

Printed and bound in the United States of America.

The information in this manual is subject to change without notice and does not represent a commitment on the part of Wenger Corporation. Wenger Corporation does not assume any responsibility for any errors that may appear in these instructions.

In no event will Wenger Corporation be liable for technical or editorial omissions made herein, nor for direct, indirect, special, incidental, or consequential damages resulting from the use or defect of these instructions. The manufacturer reserves the right to change this product at any time.

The information in this document is not intended to cover all possible conditions and situations that might occur. The end user must exercise caution and common sense when assembling or installing Wenger Corporation products. If any questions or problems arise, call Wenger Corporation - Syracuse Operations at (800) 836-1885 or +1-315-451-3440 worldwide.

## ***Manufacturer***

The Counterweight Rigging Systems are manufactured by:

Wenger Corporation - Syracuse Operations  
7041 Interstate Island Road  
Syracuse, NY 13209  
(800) 836-1885 • +1 (315) 451-3440  
jrclancy.com

## ***Intended Use***

- This product is intended for indoor use in normal ambient temperature and humidity conditions — it must not be exposed to outside weather conditions.
- This product is intended to be installed and operated only as described in these instructions.

## ***Warranty***

Warranty information is available at jrclancy.com.

## **Safety Precautions**

---

Throughout this document you may find cautions and warnings which are defined as follows:

- **DANGER:** Failure to follow the instruction will result in death, or serious injury, or damage to property.
- **WARNING:** Failure to follow the instruction could result in death, or serious injury, or damage to property.
- **CAUTION:** Failure to follow the instruction could result in minor injury or damage to property.
- **NOTICE:** Indicates information that is considered important but not hazard related.

Read all of these safety instructions before using the equipment.

### **⚠ WARNING**

- *Make sure anyone installing or using the equipment has read and understands these instructions.*
- *Failure to comply with the Dangers, Warnings, Cautions and Notices in this document can result in damage to property or serious injury.*
- *Always observe and comply with the Dangers, Warnings, Cautions and Notices posted on the system equipment.*

### **⚠ WARNING**

*A competent person must be present and available whenever any operation or maintenance procedures are performed on any system.*

A "competent person" is defined as one who is capable of identifying existing and predictable hazards in the surroundings or working conditions, which are unsanitary, hazardous, or dangerous to employees, and who has authorization to take prompt corrective measures to eliminate them.

# Counterweight Rigging Systems

## Single Purchase Counterweight Set Description

A single purchase counterweight set is a mechanical system designed to move scenery, lighting equipment, etc. vertically within a performance space. Steel or cast iron counterweights are held in an arbor to balance the load over the stage and thus reduce the amount of effort required to raise or lower the load. The total weight of the batten, scenery or lights, and the wire rope located below the loft blocks (the "load") balances the total weight of the counterweights, arbor and wire rope located below the head block.

## Double Purchase Counterweight Set Description

A double purchase counterweight set is a 2:1 mechanical system designed to move scenery, lighting equipment, etc., vertically within a performance space. Steel or cast iron counterweights are held in the arbor to balance the load over the stage and thus reduce the amount of effort required to raise or lower the load.

In a double purchase set, the batten travels two feet for every foot of arbor travel. The arbor moves at half the speed and has half the travel of the batten. This is accomplished by wrapping the lift and operating lines around sheaves at the top and bottom of the arbor and tying off their ends at the head block and floor. To balance this system there must be 2 lb (0.9 kg) of weight on the arbor side of the set to balance each pound (0.5 kg) of weight on the batten side of the set.

The total weight of the batten, scenery or lights, and the wire rope located below the loft blocks (the "load") balances the total weight of the counterweights, arbor and wire rope located below the head block.

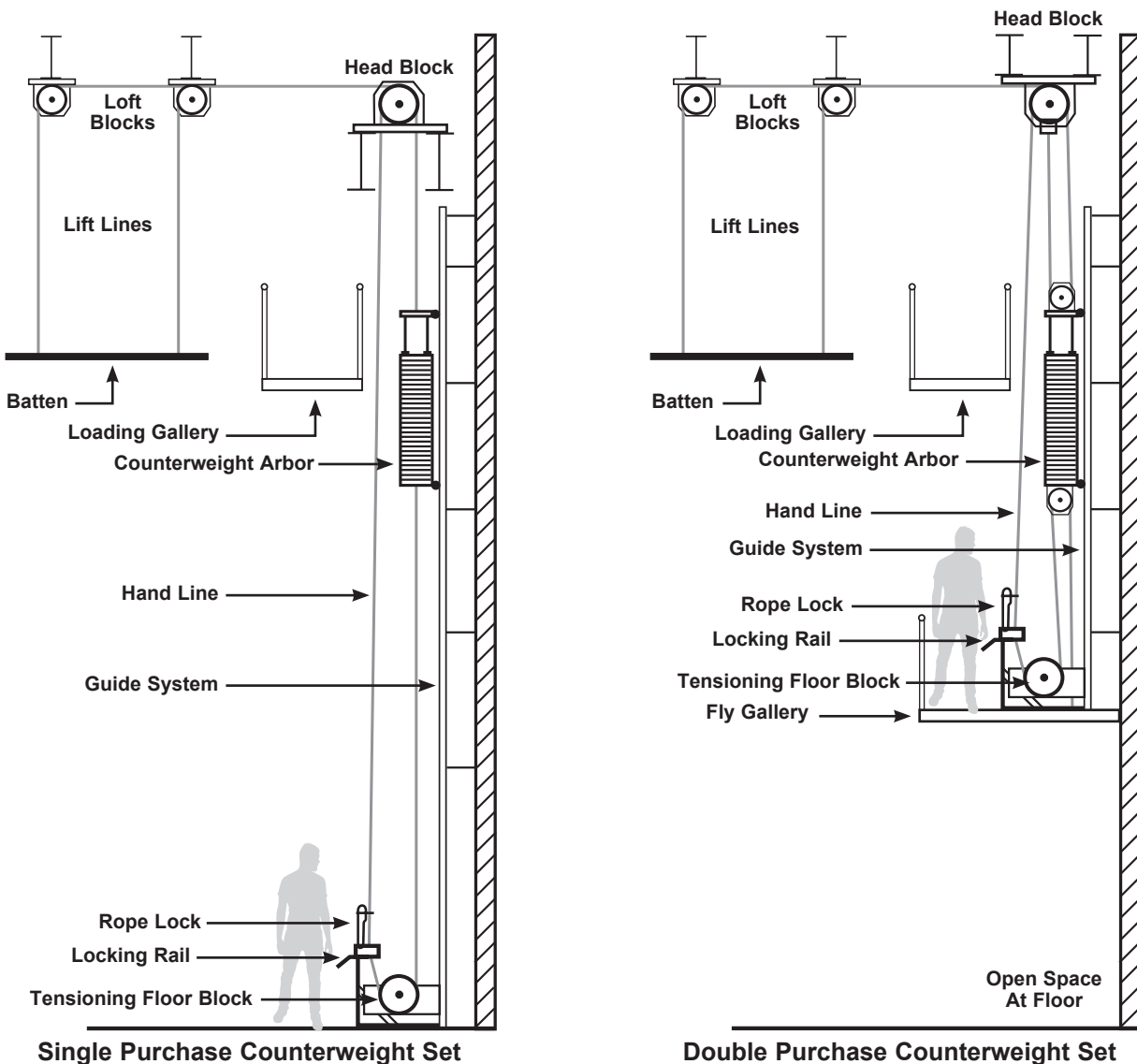

# Counterweight Rigging Systems (continued)

---

## Balance

When the forces are equal, the set is "in balance". If the "load" is greater than the arbor weight directly below the head block, the set is "batten heavy". If the arbor weight is greater than the weight below the loft blocks, the set is "arbor heavy". When the set is "in balance" the effort required to move the set is only the amount needed to overcome system friction and the inertia of the total mass (equipment load and counterweights).

### **⚠ WARNING**

**Unbalanced sets can escape control and crash.**

- **Crashes can cause serious injury or death.**
- **Keep sets in balance. Follow written instructions when sets must be operated while not balanced.**

### **⚠ CAUTION**

- **Do not operate without proper training and authorization.**
- **Read equipment manufacturer's manual before using this system. Failure to do so can result in serious injury or death.**

Note that exact balance is only achieved at one point (midway) during the set's travel due to the weight of the lifting cables passing over the head and loft blocks.

Even when a double purchase set is in balance, the set may still be somewhat difficult to operate. Double purchase sets have greater mass and more friction because of the additional blocks, cable and counterweights required.

## Components

### Loft Block

Loft blocks are located between the head block and the load, to support the lift lines and change their direction of travel. Each loft block typically carries only a portion of the load.

### Head Block

Head blocks are located between the loft blocks and arbor; they collect and support the lift lines and change their direction. They also support the hand line. The head block typically carries the full load of the set.

### Arbor

Counterweight arbors hold the weight needed to counterbalance the load on the batten. The hand line used to operate the set is connected to the top and bottom of the arbor.

### Arbor Guide

Arbors need guides to keep them from hitting other arbors or objects when the hand lines are pulled. The guides generally consist of tensioned wires that pass through holes in the arbor top and bottom or rigid steel "T" or aluminum "J" shapes.

### Stop Batten

Hardwood or similar intersection present at the top and bottom of the arbor guide to indicate end of travel and stop the arbor from crashing into the head block and floor block.

### Floor Block

Floor blocks are located below the arbors to keep the hand line in tension and to change the direction of the hand line. Many floor blocks are adjustable to compensate for stretch in hand lines and maintain a constant tension in the line.

### Hand Line

The hand line (also called the "purchase line" or "operating line") is typically a 3/4" to 1" (19 to 25 mm) fiber or synthetic rope that allows the operator to control the movement of the set. If the on stage line (the front of the hand line looping between the floor block and head block) is pulled down, the arbor will rise and the batten will lower. If the off stage line (the back of the hand line looping between the bottom of the arbor and the floor block) is pulled down, the arbor will be lowered and the batten will rise. In these instructions, reference will be made to the motion of a set with respect to the batten and the on stage line. To "raise the set" means to raise the batten. When a batten is at its maximum high trim (just under the loft blocks or gridiron) and the arbor is at its lowest position, the set is considered to be full out. Conversely, when battens are at their lowest trim (the bottom of the batten is generally about 4' to 5' [1219 to 1524 mm] above the stage floor) and the arbor is at its highest position, the set is considered to be full in.

## Counterweight Rigging Systems (continued)

### Components (continued)

#### Rope Lock

Rope locks are used to hold a balanced system load in position at the locking rail via the hand line, and must not be used to attempt to hold an out of balance load.

Rope locks should be adjusted by an authorized person to hold an out of balance load not more than 50 lb (23 kg). Rope locks should be adjusted to grip, but not crush the rope. Adjustment should be checked regularly, as the rope diameter may change with temperature, humidity, load, and wear.

Rope locks are not intended to brake or slow the speed of a set, nor should they be used in an attempt to control the speed of an unbalanced set. Large out of balance loads will move or "run through the rope lock", causing a serious safety hazard.

When sets are significantly out of balance, they need to be tied off in a manner that will safely hold the out of balance load.

#### Batten

The batten can be a pipe, truss, or other horizontal member that is supported by the lifting cables. Curtains, scenery, and lights are clamped or tied to a batten.

Allowable batten loads:

Batten	Wt/Ft	Load Type	Criteria	Span Between Lift Lines								
				8'	9'	10'	11'	12'	13'	14'	15'	
1" Schedule 40	1.68	Uniform	Strength	27	21	17	14	11	9	8	7	lb/ft
		Uniform	Deflection	20	13	9	7	5	4	3	2	lb/ft
		Point	Strength	93	82	74	67	62	57	53	49	lb
		Point	Deflection	56	44	36	29	25	21	18	16	lb
1-¼" Schedule 40	2.27	Uniform	Strength	48	37	30	24	20	17	14	12	lb/ft
		Uniform	Deflection	45	31	22	16	12	9	7	5	lb/ft
		Point	Strength	160	142	128	116	107	98	91	85	lb
		Point	Deflection	124	98	79	65	55	47	40	35	lb
1-¼" Schedule 80	3	Uniform	Strength	61	48	38	31	26	21	18	15	lb/ft
		Uniform	Deflection	56	39	28	20	15	11	9	6	lb/ft
		Point	Strength	206	183	165	150	137	127	118	110	lb
		Point	Deflection	155	123	99	82	69	59	51	44	lb
1-½" Schedule 40	2.72	Uniform	Strength	66	52	41	34	28	23	20	17	lb/ft
		Uniform	Deflection	72	50	36	26	20	15	12	9	lb/ft
		Point	Strength	221	196	176	160	147	136	126	118	lb
		Point	Deflection	197	155	126	104	87	74	64	56	lb
1-½" Schedule 80	3.63	Uniform	Strength	86	67	54	44	36	30	26	22	lb/ft
		Uniform	Deflection	91	63	45	33	25	19	15	11	lb/ft
		Point	Strength	288	256	230	209	192	177	164	153	lb
		Point	Deflection	250	197	160	132	111	95	82	71	lb
2" Schedule 40	3.66	Uniform	Strength	113	89	71	58	48	41	34	30	lb/ft
		Uniform	Deflection	156	109	78	58	44	34	27	21	lb/ft
		Point	Strength	374	332	299	272	249	230	213	199	lb
		Point	Deflection	421	333	269	223	187	159	137	120	lb

- All loads listed at the allowable static loads based on the requirements on ANSI E1.6-1 Powered Hoist Systems section 6.6.
- Characteristic load assumed to be 125% of the static load.
- Batten strength is limited so that the load imposed by the characteristic load does not exceed 75% of the allowable strength per AISC 360-05 (Specification for Steel Buildings - Allowable Stress Design).
- Batten deflection is limited so that the calculated deflection due to the characteristic load not exceed L/180.
- Battens assumed to be continuous over three spans.
- Battens extend beyond last lift line by 3 feet or less.
- ANSI E1.4 (Manual Counterweight Rigging Systems) requires battens to support 30 lb/ft or 100 lb point load while limiting deflection to L/180. Spans highlighted in green meet this criteria.

# Counterweight Set Operation

## NOTICE

*If your manual counterweight system doesn't have a loading gallery, it makes loading operations more difficult and more likely that there will be times when sets are significantly out of balance during loading and unloading operations. Plan operations carefully and use extreme care to avoid serious injury or equipment damage.*

## ⚠ WARNING

**Counterweight sets can escape from operator control and crash.**

- **Crashes can result in serious injury or death.**
- **If a counterweight set escapes from control, shout a warning to others.**
- **Get away from moving equipment.**
- **DO NOT ATTEMPT to stop the set by grabbing the hand line or engaging the rope lock.**

**Unbalanced sets can easily escape control and crash.**

- **Crashes can cause serious injury or death.**
- **Keep sets in balance. Follow written instructions when sets must be operated while not balanced.**

**Untrained and inattentive operators cause accidents. You are responsible for:**

- **The safety of those around you.**
- **Identifying and evaluating hazards.**
- **Determining and using correct methods of operation.**

## ⚠ CAUTION

- **Do not operate without proper training and authorization.**
- **Read equipment manufacturers manual before using this system. Failure to do so can result in serious injury or death.**

## General Information

- The key to operation of a counterweighted system is to always keep the system in a stable condition: Either the set must be in balance; or the heavy side of the system (arbor or batten) should be in its lowest position. If the heavy side of the system is above or below its stop batten, you are trying to defy gravity and have a potentially dangerous condition.
- If a counterweight set can't be balanced exactly, it is usually better to make the set arbor heavy so the batten won't accidentally descend and possibly injure someone. An out of balanced load must remain within the 50 lb (23 kg) limit of the rope lock.
- While loading or unloading sets, a competent safety person must be stationed near the rail to prevent anyone from releasing a rope lock by mistake and to keep other people at a safe distance from the work area. Newer rope locks may be padlocked to prevent opening.
- Identify the empty trim (or "pipe") weight for each batten so the trim weights will not be mistakenly removed. This will also speed up the unloading process. Pipe weights can be identified by painting them red or yellow, or by strapping them in place with flat metal bands or plastic cable ties. Do not use chain, rope or cable to strap the weights, as this will cause weights placed above the chains to rock.
- Take care to keep the weights in neat stacks at the sides of the gallery. Weights that are evenly stacked are more stable and less likely to topple. To keep weights from being kicked off the gallery accidentally, no weight stack should exceed the height of the toe boards at the edge of the gallery. Keep stacks the same height to prevent tripping. Put only one size weight in each stack to speed batten loading. Distribute the stacks evenly along the sides of the gallery to avoid concentrating too much weight in one location. Do not overload the gallery.
- If there is not a loading gallery counterweight must be stored on the floor. Places must be found that are convenient to the locking rail but do not present a tripping hazard or inconvenience operating the sets. Keep counterweight stacks the same height to prevent tripping. Put only one size weight in each stack to speed batten loading.



# Counterweight Set Operation (continued)

---

## General Precautions

1. Pay attention to what is happening around you. "Think"
2. Always look around when entering the stage house, especially up.
3. Remove unnecessary items from your pockets and belt before going above the stage floor.
4. Secure any needed tools to your body before going above the stage floor.
5. Wear a hard hat when "setting" or "striking" a show.
6. Wear heavy-duty work gloves.
7. Always wear safety shoes.
8. Do not wear loose fitting clothes and jewelry.
9. Secure long hair.

## Handling Counterweight

Counterweights are made from steel or cast iron. A slot is provided in each end to accommodate the arbor rods. Weights supplied by Wenger Corporation have two diagonally opposite corners removed. Alternating the position of the weights in a stack or arbor creates finger holds.

Arbors are provided with spreader plates. These are flat bars with holes sized to fit the arbor rods. Spreader plates serve two functions. One spreader may be used to mark the top of the house or balance load. Secondly and most importantly, they ensure that, should the set run away from the operator and strike the top or bottom stop batten or crash rail, the arbor rods will not spread and allow the weights to topple out of the arbor. The spreader plates must be located between the counterweights every 2' (610 mm), or less, to accomplish this function.

A stop collar, with a red hand screw, is provided on each rod above the top spreader plate. These help to keep counterweight in place during an accidental crash. Note that the front collar is welded to the upper spreader plate.

FrontLoader Arbors are provided with secure "box sections" which utilize independent doors each with individual double action latches. These latches are designed to securely contain the counterweights in to each individual "box section".

The door can be opened and used to move the hand line aside enabling clear access to each "box section" for ease of loading.

## **⚠ WARNING**

**Counterweight sets can escape from operator control and crash.**

- **Falling counterweight may cause serious injury.**
- **ALWAYS check for people or obstructions before operating.**
- **PEOPLE MUST NOT BE NEAR OR UNDER MOVING ARBORS OR BATTENS.**
- **ALWAYS place spreader plates every 2' (610 mm) in the weight stack.**
- **ALWAYS lock stop collars firmly on top of the stack.**
- **NEVER place weight on top of stop collars.**
- **ALWAYS secure door latch after loading each counterweight compartment.**
- **ALWAYS check that the set is in balance and that the stop collars are in place and locked before moving a set.**
- **Do not use rope lock to hold out of balance loads greater than 50 lb (23 kg).**



# ***Operation of Systems With a Loading Bridge***

---

## ***Attaching Loads To Battens and Loading Arbors***

1. Bring the empty batten to the **full in** (or Low Trim) position just above the stage floor. Engage the rope lock and set the oval safety ring.
  2. The arbor should be braced against the upper stop batten. All the weight should be removed from the arbor, except for the "pipe weight" used to balance the weight of the empty batten. This ensures the batten (which is at its lowest level) is the same weight or heavier than the arbor, so that the system is in a stable condition.
  3. Securely attach the scenery, drapery, track, etc. to the batten. Be sure that the scenery chains, clamps or other hanging devices are
    - (1) strong enough to hold the load,
    - (2) securely fastened,
    - (3) in good condition.

If the scenery is suspended by just a few pickup points, it is important that they be attached to the batten near the lift lines to avoid deforming the batten.
  4. Once the equipment has been safely secured to the batten, load the arbor at the loading gallery level using the following procedure:
    - a. Find a comfortable and secure place to stand before lifting and moving counterweights.
    - b. By yelling "clear the rail" or some other agreed upon command, make sure that all persons are clear from the areas on the stage below the arbors and loading gallery.
    - c. Rod Arbors
      - i. Raise the spreader plates and stop collars and hold them. A spring-loaded "Pony" clamp may be used to hold them out of the way during loading.
      - ii. Load the counterweight into the carriage by setting the weight on the stack vertically, using both hands. Ease the top back until the top slot fits around the rear rod and ease the bottom forward. Grasp the bottom of the weight between the heels of the hands and bring forward so that it slides around the front rod.
      - iii. Other methods are possible and acceptable as long as two things are kept in mind:  
First, keep fingers, etc. out from under the weights.  
Second, always maintain complete control over the weights
      - iv. Insert spreader plates every two feet as the weight stack is built. Fill the arbor with counterweight to equal the weight of the batten and scenery.
      - v. Remove any clamps securing the spreader plates and slide spreader plates down to the top of the weight stack. Extra spreader plates may be secured under the top spreader plate.
      - vi. Hand tighten the setscrews on both stop collars to secure the spreader plates and weights.
  5. FrontLoader Arbors
    - a. Release the door latch and swing open the door.
    - b. Load the counterweight into the lowest available "Box" section by setting the weight on the stack vertically, using the hand cut out. Ease the weight into the box by sliding it inwards until half of the weight is inside the "Box", begin to gently lower the weight until contacting the shelf (or previous weight), move your fingers out of the hand pocket to protect them from injury, continue to slide the weight into the "Box" until it contacts the back wall.
    - c. Always maintain a safe opening for the door area.
  6. Double Purchase Arbors
    - a. A double purchase set requires adding or removing 2 lb (0.9 kg) of counterweight for each 1 lb (0.5 kg) of batten load in order to balance the set.
-

## **Operation of Systems With a Loading Bridge (continued)**

### ***Attaching Loads To Battens and Loading Arbors (continued)***

The set should always be in balance or under operator control before releasing the rope lock. ***In balance*** means the weight of the batten and load equals the weight of the arbor and counterweight. Any excessive tension in the hand line above or below the rope lock means that the set is significantly out of balance. Tension in the hand line above the rope lock and a slack condition in the hand line under the arbor indicate that the arbor is too heavy. Tension below the rope lock and a slack condition in the hand line above the rope lock indicates that the batten is too heavy.

After determining that the set is close to balanced, open the rope lock to confirm the balance while an assistant holds the hand line. Close the rope lock again and make any needed adjustment to the counterweight. Remember that rope locks are intended to lock arbors and loads that are balanced. A properly adjusted rope lock should hold about 50 lb (23 kg). Adjusting the rope lock to hold additional loads only wears out hand lines faster and increases the potential for an accident in the form of a runaway counterweight set.

In systems that have long travels or many lift lines, there will be transfer of cable weight between the arbor side and the batten side as the lift lines go over the head block. This can lead to a set that is in balance at one point of its travel while being out of balance at other points in its travel.

### ***Removing Loads and Unloading Arbors***

Removing or "striking" pieces is essentially done by reversing the order of the loading procedure:

1. Run the arbor up to the loading gallery.
2. Make an announcement to clear the rail.
3. Unload the counterweight.
4. Unload the batten only after the counterweight has been unloaded.
5. Remember to leave enough weight in the arbor to balance permanent loads such as the pipe batten or curtain tracks.
6. Secure spreader plates and stop collars/FrontLoader doors.
7. Store unused weight safely, below the top of any kickplates, and where they cannot fall to the stage or pose a trip hazard.

# **Operation of Systems Without a Loading Bridge**

---

## **Attaching Loads To Battens and Loading Arbors**

### **⚠ CAUTION**

***Systems without loading galleries will require working with out of balance sets. Several methods are described in the following section. Choosing the best method of operation depends upon the specific design of your system, the nature of the out of balance condition, and your facility's personnel and equipment resources.***

***A competent person must determine which procedure is the appropriate one for a given situation. It may be necessary to perform a hazard assessment to identify hazards, assess the severity of the hazards, and protect against the hazard. All operators must be trained to handle the different conditions that will be encountered and to operate the sets efficiently and with safety.***

1. Lower the pipe batten to its low trim near the floor. Engage the rope lock and set the oval safety ring.
  2. Hang only equipment from the batten that can easily be controlled by one or two people. Be sure the equipment is firmly attached. Spread the load along the batten or attach it near the lift lines to avoid damage to the batten.
  3. Get help to haul the arbor to the floor. Restrain the arbor and add counterweight to balance the weight of the added equipment.
  4. A double purchase set requires adding or removing 2 lb (0.9 kg) of counterweight for each 1 lb (0.5 kg) of load in order to balance the set.
  5. When loading, place counterweight on the stack vertically; ease the top back until the slow engages the rear arbor rod, then ease the bottom forward. Grip sides of the weight between the palms and bring it forward until it slides around the front rod. Alternate notch direction of J.R. Clancy counterweights to provide finger grips at corners.
  6. Other methods are possible and acceptable as long as two things are kept in mind: first keep fingers, etc. out from under the weights. Second, always maintain complete control over the weights.
  7. Fill the arbor with counterweight to equal the weight of the batten and scenery.
  8. Rod Arbors
    - a. Insert spreader plates every two feet as the weight stack is built.
    - b. Remove any clamps securing the spreader plates and slide spreader plates down to the top of the weight stack. Extra spreader plates may be secured under the top spreader plate.
    - c. Hand tighten the setscrew on both stop collars to secure the spreader plates and weights.
  9. FrontLoader Arbors
    - a. Release the door latch and swing open the door.
    - b. Load the counterweight into the "Box" section by setting the weight on the stack vertically, using the hand cut out. Ease the weight into the box by sliding it inwards until half of the weight is inside the box arbor, begin to gently lower the weight until contacting the shelf (or previous weight), move your fingers out of the hand pocket to protect them from injury, continue to slide the weight into the box until it contacts the back wall.
    - c. Always maintain a safe opening for the door area.
  10. Double Purchase Arbors
    - a. A double purchase set requires adding or removing 2 lb (0.9 kg) of counterweight for each 1 lb (0.5 kg) of batten load in order to balance the set.
  11. Heavier loads can be hung by partially loading the arbor first, then add equipment and finally, more counterweight. Never allow the set to be more out of balance than can be controlled by the operators.
  12. Check the load balance in the set by feeling the tension in both sides of the hand line before carefully opening the rope lock to verify the balance. Close the rope lock and adjust the weight balance if necessary. See "Capstan (Bull Hoist)" on page 14 for additional information.
-

## ***Operation of Systems Without a Loading Bridge (cont.)***

---

### ***Attaching Loads To Battens and Loading Arbors (continued)***

The set should always be in balance or under operator control before releasing the rope lock. ***In balance*** means the weight of the batten and load equals the weight of the arbor and counterweight. Any excessive tension in the hand line above or below the rope lock means that the set is significantly out of balance. Tension in the hand line above the rope lock and a slack condition in the hand line under the arbor indicate that the arbor is too heavy. Tension below the rope lock and a slack condition in the hand line above the rope lock indicates that the batten is too heavy.

After determining that the set is close to balanced, open the rope lock to confirm the balance while an assistant holds the hand line. Close the rope lock again and make any needed adjustment to the counterweight. Remember that rope locks are intended to lock arbors and loads that are balanced. A properly adjusted rope lock should hold about 50 lb (23 kg). Adjusting the rope lock to hold additional loads only wears out hand lines faster and increases the potential for an accident in the form of a runaway counterweight set.

In systems that have long travels or many lift lines, there will be transfer of cable weight between the arbor side and the batten side as the lift lines go over the head block. This can lead to a set that is in balance at one point of its travel while being out of balance at other points in its travel.

### ***Removing Loads and Unloading Arbors***

Removing or "striking" pieces is essentially done by reversing the order of the loading procedure:

1. When removing a load, alternate between removing batten load and counterweight so the set stays within 50 lb (23 kg) +/- of balance.
2. Alternately use a capstan hoist or other means of controlling the imbalance. Refer to pages 14-16 for additional information.
3. Remember to leave enough weight in the arbor to balance permanent loads such as the pipe batten or curtain tracks.
4. Secure spreader plates and stop collars / FrontLoader doors.
5. Store unused weight safely.

### ***Operating a Counterweight Set***

1. Start by identifying the arbor visually and by looking at the locking rail that is provided with index cards. These identify the set number and often its contents, function, estimated weight, and/or hazards.
2. Look for obstructions that might prevent its safe operation before operating any set.
3. When approaching an arbor for the first time, especially when it is loaded, observation of the front and back purchase lines will indicate the condition of the balance. If the front line is taut above the rope lock and the rear lines below the arbor are loose, the set is arbor heavy. If the rear lines are taut and the front line is loose, the set is batten heavy. As an added precaution, simply squeezing the front and rear lines together will indicate movement more rapidly than visual observation as the rope lock is opened. If the set is out of balance, correct it. If you must operate it in an "as is" condition, get help from a competent person and perform a hazard assessment before moving the set.
4. A properly balanced counterweight set should be within 50 lb (23 kg) of neutral balance at the midpoint of travel. However, if there are several lift lines, or the travel distance is long, the set may be out of balance at the ends of travel. Get help if operation becomes difficult.
5. Before moving the batten or arbor, it is good practice to yell "Batten number X coming in (or going out)". Make sure that people and other items are clear of any moving battens. Use another person as a "spotter" if you cannot see the moving batten during its full travel.
6. Make use of stanchions, signs or other equipment to rope off the stage and/or loading area to alert bystanders from walking into a hazardous situation when loading and unloading counterweight.

## ***Operation of Systems Without a Loading Bridge (cont.)***

---

### ***Operating a Counterweight Set (continued)***

6. To operate the set, release the oval metal safety ring that is used to prevent the lock from opening. The ring is fitted around the operating line and is slipped over the handle of the rope lock whenever it is not in operation. Then release the rope lock handle slowly until the exact state of balance is known.
  - a. The rope locks are provided with a set of holes in the front of the casting that will accept a standard lock or a lock-out tag to prevent any unauthorized use of the system.
  - b. The rope locks are furnished with an open slot in the handle. The slot can be used to lock several rope locks as follows:
    - c. A cable can be passed through all of the rope lock handles with the oval rings in place and locked, fasten the cable ends to prevent any unauthorized operation of the counterweight system.
7. Because of the friction inherent in any counterweight set, it may be necessary to pull a balanced set both up and down. If the pull required is excessive or different than normal, stop at once, engage the rope lock and find out what is wrong.
8. When the batten reaches the desired position, engage the rope lock and the safety ring. Use care to prevent crashing the arbor into a top or bottom stop batten by slowing down before hitting the batten. If a position must be found repeatedly, the hand line can be "spiked" or "stabbed" with string through the hand line. Do not use adhesive tape to mark the hand line because it will leave a sticky residue when removed.
9. If the hand line has stretched or shrunk due to changes in load or humidity, the set can be harder to operate. Most systems have floor blocks that can be easily adjusted to remove slack or relieve excessive tension in the hand line.
10. Counterweight rigging with manila or other natural fiber rope hand lines require much more frequent adjustment for easy operation than systems with polyester hand lines because the length of rope changes with temperature and humidity conditions. If the system hand lines are equipped with natural fiber rope, the operator should wear gloves to prevent getting slivers in the hands.
11. Guide rail mounted tension blocks can be adjusted by pushing the block kick tab down with your foot (or a rod if in a counterweight pit) while pulling forward on the back hand line. This will release the tension block guide shoes and allow the block's weight to automatically adjust the tension in the hand line.

### ***Working With Out Of Balance Loads***

Some loads, such as curtains or tall scenery, may apply a change in load on the system as they are raised or lowered. For example, when a curtain is first tied to a batten that is near the floor, most of the curtain's weight is on the stage floor. As the batten is lifted, the load on the batten increases making the loading procedure more difficult. Systems without a loading gallery, or where there is inadequate access to the arbors for proper loading may also require working with out of balance sets.

Choosing the best method of operation depends upon the specific design of your system, the nature of the out of balance condition, and your facility's personnel and equipment resources. A competent person must determine which procedure is the appropriate one for a given situation. It may be necessary to perform a hazard assessment to identify hazards, assess the severity of the hazards, and protect against the hazard.

## **Operation of Systems Without a Loading Bridge (cont.)**

### **Capstan (Bull Hoist)**

One method of working with changing loads is the use of a capstan hoist, which requires the supervision of a competent person.

A capstan hoist is a portable, dollied hoist with a rope capstan drum that is used to haul an arbor down when there is an unbalanced load on the batten. It may also be used to slowly lower a loaded batten while the arbor is under the control of the hoist. The tension in the hauling line keeps the rope tightened around the capstan drum. See the detailed instructions provided with your capstan hoist. In brief:

With the set batten heavy, attach the capstan to the bottom of the arbor and allow the batten to come in. Remove or add counterweight and equipment as needed so there is always tension on the capstan line.

Use the capstan to raise and lower the batten to permit loading and unloading.

When finished, lower the arbor and check the load balance. When satisfied, set the rope lock and remove the capstan. Last, check the set balance again by opening the rope lock while holding the hand line.

A bull hoist is similar to a capstan hoist except that it uses a wire rope cable to haul or control the arbor.

### **NOTICE**

***Capstan or bull hoists require special modifications to standard locking rails and arbors. Verify that your system has these modifications before using a capstan or bull hoist. If your system was supplied with a capstan or bull hoist, refer to the hoist instructions for complete operational information.***

### **Block And Tackle**

1. Bring the empty batten to the full out (or high trim) above the stage floor. Engage the rope lock and set the oval safety ring.
2. Attach an appropriately rated block and tackle assembly to the bottom of the arbor and secure the bottom block to the locking rail with a suitably rated chain and shackle. Confirm that the locking rail is rated to carry the load that will be applied. The block and tackle may also be secured to the hand line using a "prussik knot". Do not secure equipment in a manner that puts tension into the floor block.



3. Release the rope lock and oval safety ring. Bring the empty batten down to the full in (or low trim) position. The arbor should be braced against the upper stop batten.
4. Securely attach the scenery, drapery, track, etc. to the batten. The scenery chains, clamps or other hanging devices must be
  - (1) strong enough to hold the load,
  - (2) securely fastened,
  - (3) in good condition.If the scenery is suspended by just a few pickup points, it is important that they be attached to the batten near the lift lines to avoid deforming the batten.
5. Once the load has been safely secured to the batten, haul the arbor down to the locking rail with the block and tackle. Load the arbor with counterweight to properly balance the load.
6. Remove the hoist or block and tackle and all temporary hardware.



## ***Operation of Systems Without a Loading Bridge (cont.)***

---

### ***Using Tag Lines***

One method of assisting the operator in moving an unbalanced load is to loop several properly sized "tag" lines over the batten in close proximity to the lift lines and have the deck crew hold these lines while the arbor is loaded at the loading gallery. Slowly let the batten up to where the scenery weight matches the arbor weight. If the scenery is not yet off the floor, adjust the arbor weight. Once the piece is in the air and in balance, one side of the tag line is released and the other side is pulled to remove the line from the batten. Be sure everyone is clear as the rope falls to the floor.

Tag lines on the batten may be used in reverse to unload the set. As the batten comes into reach (often with a ladder or personnel lift), a crew member drapes tag lines over the batten. The deck crew then pulls the batten down as the scenery or curtains are laid on the floor. Keep the tag lines on the batten and secured by several persons until the arbor is unloaded or secured. The crew should grab the batten to directly assist the operation for the last few feet.

Do not "hang" your arms over the batten. If the batten starts to move up, the batten may lift you off the floor.

Care should be taken not to crash the arbor against the upper stop batten or the head block. Once the batten is at low trim, the deck crew should hold onto the batten until the arbor can be unloaded down to "pipe weight".

### ***Incremental Loading***

If loads can be attached to the batten in "stages" (i.e. lighting equipment or tracks and curtains), loading the set can be done incrementally. This is particularly useful for systems without loading galleries.

Run the set so the batten is full in (at low trim). Attach the load to the batten so that the load is slightly out of balance, but the arbor may still be pulled down to the floor by a couple of people. Once the arbor is hauled down, secure it with a snub line (or sunday) from the locking rail top to the load side (back or offstage side) of the hand line using a prussik knot. When it is at the floor, overload the arbor slightly, and pull it back up. When the arbor is up, again secure the arbor with a snub line.

Add more equipment to the batten until the load is slightly more than that in the arbor. Repeat the process until all the loads are attached and the set is balanced.

Unloading the set is performed by reversing the process.

### ***Using Temporary Weights (Sandbags)***

If items attached to the batten need to be removed temporarily, sandbags may be attached at the lift line location on the batten to simulate the load. These temporary weights should be added to the batten prior to removing the scenery or equipment.

### ***Twisting the Hand Line***

If the out of balance condition is less than 150 lb (68 kg), you can take the on- and off-stage hand lines and twist them together four or five times. This adds friction into the hand line and keeps the set from moving.

A belaying pin or steel pipe may be held in the twists by someone to help hold the lines. Never insert end of the pin or pipe between the arbor guides tracks to hold the load. It may release unexpectedly and cause serious injury.

The out of balance load can be controlled by slowly releasing the lines.

This operation places extra load into the floor block, which is typically not designed for significant out of balance conditions. Caution should be used to ensure that the floor blocks and their guides are not bent or damaged. Limit out of balance loads to 150 lb (68 kg).



## **Operation of Systems Without a Loading Bridge (cont.)**

### ***"Line Lok" or "Uncle Buddy"***

A few commercially available devices can be used to hold the hand lines of a set together in an out of balance condition. These are steel fabrications that mimic the twisting of the hand lines as described above. As with twisting the hand lines, these devices may damage the floor block if not used correctly. Refer to the instructions that come with these devices.

### ***Human Assisted Hauling***

If the unbalanced load is small, a few people may gather around the hand line and pull the arbor down (or the batten up) with brute strength. This approach may appear simple but requires careful coordination. Plan where each person can stand safely, and how the individuals will work together to handle the load without interfering with each other or endangering each other.

If this method is used, a snub line or chain should be rigged to the locking rail and be readily available to secure the arbor once it is in position.

### ***Weight Compensation***

As arbors are raised, they become lighter because some of the lift line weight transfers from the head block to the loft blocks. In smaller systems the change is minor. In systems with long travel or with many lift lines, the change can make it difficult, or impossible, for an operator to maintain control.

1. Arbors are sometimes furnished with a chain or cable weight that hangs from the bottom of the arbor and attaches to the guide system at mid elevation or by means of a lightweight cable attaches back to the arbor top.
2. The system drawings will provide details of the system if one is present.

# **Counterweight Set Maintenance**

---

## **General**

All equipment requires periodic maintenance and inspection to insure long life and trouble free operation. Get your system inspected on a regular, scheduled basis and keep records. These inspections will provide information on length of service and any changes in performance which might indicate wearing parts.

It is the responsibility of the venue owner to get its rigging system regularly inspected and maintained by a qualified person as well as the continuous training of its operators. Failure to properly maintain equipment may result in serious injury.

## **Everyday Observation**

In addition to regularly scheduled inspections you need to know your system and ask the following questions each time a set is operated.

- Is the set balanced?
- Is the rope lock properly adjusted?
- Is there excessive friction in the system?
- Is it too hard to operate?
- Are the spreader plates properly spaced among the counterweights and are the stop collars down on the top weight and locked?
- Are there any obstructions or fouled lines?

Any "no" answer should result in an immediate halt to the operation of the set until the fault is corrected.

## **Inspection**

Time, temperature, humidity and both the frequency and severity of operation affect rigging items. A schedule should be established and followed for checking all items. The frequency with which inspections should be done depends upon the above parameters and will be unique to your program and location. Your inspection should at least include the items on an inspection form. A sample is included at the end of this section.

When heavy or complicated equipment exists, Wenger Corporation suggests that you hire a qualified stage rigging firm to perform a full evaluation of your facility on a regular basis per ANSI E1-47. This is in addition to your own periodic inspection program. We further suggest that you maintain full records of all inspections and maintenance for government (OSHA) and insurance purposes. Maintenance records are also useful in making future checks and in evaluating the potential useful life of equipment.

# **Counterweight Set Maintenance (continued)**

---

## **Inspection Check List**

Create an inspection checklist, which works for you and includes items that are unique to your facility and the uses to which it is put. The following list of potential items and questions is only intended as a guide to get you started in creating your own inspection list. Check for the following:

1. Lift Lines
  - a. Abrasion, rust, broken strands or kinks
  - b. Check that terminations are tight, properly applied, worn or cracked
  - c. Check that turnbuckles are adjusted and safety wired
2. Hand Lines
  - a. Abrasion
  - b. Overly smooth or glossy
  - c. Kinking
  - d. Overstressed
  - e. Rot or dry rot
  - f. Connections
3. Locking Rail
  - a. Damage
  - b. Properly and securely mounted
  - c. Index cards in place and correct
4. Rope Locks
  - a. Properly adjusted
  - b. In good condition
  - c. Not worn on handles and/or dogs (the gripping cams inside rope lock)
  - d. Complete with safety rings in place
5. Head, Loft, Mule and Floor Blocks
  - a. Properly mounted
  - b. Bearings and shafts are in good shape
  - c. Sheave groove wear
  - d. Guide shoe wear on floor blocks
6. Counterweight Arbor – check:
  - a. Top and bottom condition
  - b. Rods and nuts (straight and tight)
  - c. Spreader plates and lock collars (in place with all hardware) - locate a spreader plate every 2' (610 mm) and keep stop collars down and locked.  
***Do not unload an arbor with weight on the batten to place spreader plates!***
7. Arbor Guides
  - a. Clean with a cleaner that will not damage the arbor guide material.  
(Do not lubricate or dirt will accumulate and cause premature wear on the guide shoes)
  - b. Straight joints match up

## ***Counterweight Set Maintenance (continued)***

---

### ***Testing***

Except for periodic rope lock adjustments, systems used under normal conditions need not be tested.

However, if you wish to test the system yourself, Wenger Corporation recommends the following procedure:

1. Fully inspect the lineset you wish to test.
  - a. Look for wear on the hand line, guide shoes, rope lock dogs (the gripping cams inside a rope lock) and cable.
  - b. Inspect all cable fittings and terminations.
  - c. Make sure all bolts and nuts are fully tightened.
2. You will want to run your test with an empty batten, so remove any scenic pieces or other items such as draperies or tracks.
3. With the arbor at "pipe weight" (just enough weight to balance the empty pipe), run the batten to its high trim and down again several times. The set will be harder to move at each end of its travel due to the transfer of the weight of the lifting cables. This is normal.
4. Listen for any abnormalities such as cables that may be rubbing or "slapping".
5. If the set is hard to run at any other point during its travel, this may indicate a problem. Typical problems include guide shoes binding in the guide tracks or cables that have "jumped" out of their grooves. If you cannot isolate the cause of your problem, contact your local stage rigging contractor for assistance or call Wenger Corporation.

To test the rope lock's setting, Wenger Corporation recommends the following procedure:

1. With the arbor at "pipe weight", fly the empty batten to its high trim, and then lower it slightly so that the arbor is about 2' (610 mm) above the bottom stop batten.
2. Close the rope lock and secure the handle with the oval ring.
3. Add 50 lb (23 kg) of weights to the arbor - If the arbor moves before all the weight is added, the rope lock setting is too loose and should be tightened by adjusting the screw on the back of the rope lock.
4. If you can add more than 50 lb (23 kg) of weights to the arbor, and it does not move, the rope lock is too tight and should be loosened by adjusting the screw on the back of the rope lock (see rope lock instructions).
5. Repeat the above process until the rope lock allows the hand line to slip at about 50 lb (23 kg).

### ***Maintenance***

J.R. Clancy's manually operated counterweight stage rigging systems are designed, manufactured and installed to provide almost a lifetime of trouble-free service under normal use. Most maintenance is preventive. Wenger Corporation suggests the following:

- Keep equipment, and the areas surrounding it, clean and free of accumulated dirt, dust and debris.
- Periodically inspect system as described above. Correct or repair any deficiencies, or replace worn equipment.
- Maintain proper adjustment of the rope lock.
- Keep tension (floor block) sheaves adjusted to minimize slack in the hand line.
- Replace burned out index strip lights.

# **Rope Locks**

---

## **General Description**

Rope locks are designed to maintain a balanced counterweight set in position by clamping the hand line to prevent unwanted up or down movement. 010-533R and 010-600R are equipped with an oval ring on the hand line that loops over the handle when it is closed to prevent accidental release. 010-2852 includes a pin locking mechanism to hold to handle closed. Depress the button on top of the handle to release the pin and open the handle. A counterweight set should be kept in balance, or very close to balance, except when equipment is being changed.

The recommended working load for J.R. Clancy rope locks operated by routine operators is within 50 lb (23 kg) of neutral balance.

## **Operation**

1. Start by identifying the counterweight set visually and by looking at the locking rail which is provided with "index cards." These identify the set number and often its contents or function.
2. Look for obstructions which might prevent its safe operation before operating any set.
3. When approaching a set for the first time, especially when it is loaded, observation of the front and back purchase lines will indicate the condition of the balance. If the front line is taut and the rear line is loose, the set may be arbor heavy. If the rear line is taut and the front line is loose, the set may be stage or batten heavy. As an added precaution, simply squeezing the front and rear lines together will indicate movement more rapidly than visual observation as the lock is opened. If the set is out of balance, correct it. If you must operate it in an "as is" condition, get help.
4. Operation
  - a. 010-533R and 010-600R: To operate the set, release the oval metal "safety ring" which is used to prevent the lock from opening accidentally under a heavy strain or if bumped. The ring is fitted permanently around the operating line and is slipped over the handle of the rope lock whenever it is not in operation. Then release the rope lock handle slowly until the exact state of balance is known.
  - b. 010-2852: To operate the set, press down on the release button on top of the handle and lower slowly until the exact state of balance is known.
5. Because of the friction inherent in any counterweight set, it will be necessary to pull a balanced set both up and down. If the pull required is excessive or different from normal, stop at once, engage the rope lock and find out what is wrong.
6. When the batten reaches the desired position, engage the rope lock and the safety ring. On 010-533R and 010-600R place the safety ring over the handle.
7. The rope locks are provided with a set of holes in the front of the casting that will accept a standard lock or a lock-out tag to prevent any unauthorized use of the system.
8. 010-533R and 010-600R: The Rope Locks are furnished with an open slot in the handle. The slot can be used to lock several rope locks as follows:
  - a. a length of flat metal bar to prevent the removal of oval safety rings on a group of sets. Use a pad lock at either end of the bar for security.
  - b. A cable can be passed through all of the rope lock handles with the oval rings in place and locked to prevent any unauthorized operation of the counterweight system.
9. The 010-600R SureLock® Rope Lock incorporates a load sensing mechanism that cannot be opened in an out of balance situation of more than 50lbs on either the batten side or the arbor side of the system, preventing runaways. When the system is out of balance the SureLock prevents the handle from being opened. The system must be brought back into balance before the operation of the lineset can occur.

## ***Rope Locks (continued)***

---

### ***Inspection***

Informal inspection should take place each time the rope lock is used. J.R. Clancy recommends a formal inspection quarterly under normal usage.

1. Check housings for signs of wear, loose or bent connections, and cracks in the housings. Check the supporting locking rail.
2. After a set has been subjected to any shock load, it should be closely inspected for damage.
3. Check for proper clamping force between the dogs and the hand line.
4. Check the cam on the end of the handle and the back of the on stage dog for signs of wear. When these parts are worn to the extent that the handle will no longer lock over center, the handle and dog should be replaced.

### ***Maintenance***

1. Tighten and adjust loose fittings as necessary.
2. Adjust the dogs as necessary to compensate for wear in the hand line, changing environmental conditions and tension in the hand line.
3. Damaged rope locks should be replaced.
4. 010-2852 EuroLock Adjustment Procedure:
  - a. Ensure batten and arbor are weighted equally before adjusting.
  - b. Loosen the vertically sliding roller bolt.
  - c. Tighten (clockwise) or loosen (counter-clockwise) the adjustment bolt until the rope slips at 50 lb (23 kg) out of balance.
  - d. Tighten the vertically sliding roller bolt.

# Locking Rails

---

## General Description

Locking rails function as mounting locations for rope locks, safety railings to keep people out of the path of moving counterweight arbors, and locations for counterweight set identification labels. Finally, the locking rail transmits loads caused by out of balance counterweight arbors into the building structure.

## Operation

Locking rails are essentially passive devices. They provide mounting locations for rope locks, have labels that provide set identification, and keep operators away from the travel path of moving arbors.

When a counterweight arbor is in a temporarily unbalanced condition during loading and unloading a line is sometimes attached to the rail and tied to the arbor handline with a stopper hitch or prusik knot. In this case the rail should be padded or checked for any sharp edges that could weaken the line.

When a portable capstan hoist is to be used, a reaction bar is installed. These are often made a part of the locking rail. See the instruction for the capstan hoist on how to engage the reaction bar.

Informal inspection should take place each time the locking rail is used. Especially look for loose floor mounting anchors and bolts and for loose rope lock bolts. J.R. Clancy recommends a formal inspection quarterly under normal usage.

### CAUTION

*Locking rails are not intended for use as operator platforms to permit several people to grip a handline when moving an out of balance set.*

## Maintenance

1. Tighten and adjust loose bolts and fittings as necessary.
2. Damaged components should be replaced.



# Counterweight Arbors

---

## General Description

1. **Counterweight Arbor:** A carriage or rack which can be filled with weights (usually flame cut steel) in sufficient quantity to balance the weight of a batten and the load hung from it (i.e., curtains, lights, tracks). Arbors are guided in some manner to minimize lateral movement during operation. The weights (called counterweights) are locked in place by some means to prevent them from falling out during an emergency or sudden impact.
2. **Arbor Types:** Counterweight arbors are grouped in two ways. They are grouped by type (single purchase or double purchase), and by the guide system employed.
  - a. **Single Purchase Arbors:** The weight of the arbor and counterweight should always equal the weight of the batten and load. The arbor requires the same travel distance as the batten.
  - b. **Double Purchase Arbors:** The arbor top contains a multi-groove sheave for the lift lines and hand line while the bottom contains a rope sheave. The arbors are usually tee guided. They are used when space for the counterweight arbors is restricted or when it is desirable to move the arbor half as far as the batten.

The counterweight arbor should be filled with counterweight to equal twice the load on the batten to achieve a balanced system.
  - c. **FrontLoader Arbors:** The weight is loaded from the front and secured in to compartments in the arbor using latching doors.
3. **Guides:** Three different guide systems are commonly used.
  - a. **Tee Guided:** The arbor has a steel bar along the back side to which a pair of guides are mounted. The guides may be grooved rollers, or plastic or fiber slider plates (usually reinforced with steel backing plates).

The guides engage a pair of tee-shaped guide bars which form a track, vertically mounted true and plumb to the wall. The guide bars are normally steel tees but may also be steel angles or aluminum tees or J's. The guides and guide bars keep the arbor in position and prevent the arbor from hitting adjacent arbors in the system as it is raised and lowered. A minimum clearance of 1" (25 mm) must be kept between the counterweights in adjacent arbors, but 2" (51 mm) is recommended for normal use.
  - b. **Wire Guided:** The arbor top and bottom have holes that engage a pair of lightly tensioned wires which guide the travel path of the arbor. This type of arbor is recommended for single purchase arbors with travels of less than 30' (9144 mm). The recommended clearance between the weights in adjacent arbors is 4" (102 mm) or more.
  - c. **Lattice Track Guided:** Each end of the arbor top and bottom contains a guide shoe with a slot that engages an angle or tee guide bar. The dual bars and supporting framework provide a semi protective enclosure along the travel path of the arbor and is a positive guiding method. This type of arbor is useful when a single arbor must be installed or the arbor must be mounted parallel to the set instead of at a right angle.

## Counterweight Arbors (continued)

---

### CAUTION

- **NEVER** move a set without permission or without checking for other people and obstructions. **PEOPLE MUST NOT BE NEAR OR UNDER MOVING ARBORS OR BATTENS.**
- **NEVER** move a set unless it is in balance and the stop collars are in place and locked.
- **NEVER** stack counterweights above the stop collars.
- **NEVER** lock the collars above the level of the weight stack when the set is in operation.
- **NEVER** put more than two feet of weights between spreader plates.
- **ALWAYS** tighten the stop collars at the top of the counterweight stack to help prevent weights from bouncing out of the carriage.

### **Inspection**

4. Counterweight arbors should be routinely checked for loose nuts, bending, and wear or damage to the guide shoes, along with loose knots, cable clips, and other fittings.
5. Tee and lattice track guide shoes should last indefinitely. If you find a lot of wear or damage, look for another source of trouble, like a bad tee joint, bent guides, or a racked or bent arbor.
6. If an out of balance arbor is allowed to run away, it will hit the end of travel stops with great force. The force may be sufficient to rack the arbor and bend the arbor rods. Look carefully at the rods and back bars, especially near the nuts. The arbor should be replaced if any evidence of damage is found. An arbor crash into the bottom stop will tend to compress the arbor and bow the rods and back bar. A crash into the top stop will force weight against the stop collars and may loosen or damage them. Also inspect the head and floor blocks, guides, and the stop battens. Replace any damaged components or hardware.
7. When lift cables are located properly on top of the arbor, the arbor should hang along its center line of gravity and not impose any great load on the guide shoes or rollers. Look for a warped arbor or cables attached in the wrong locations. If the guides are wearing unequally.

### **Maintenance**

1. Tighten and adjust loose fittings as necessary.
2. Safety all turnbuckles after adjustment.
3. **Do not over tighten** turnbuckles on wire guides.
4. Spreader plates should be located within the stack of counterweights on 2' (610 mm) centers or less.
5. Stop collars should rest on the top spreader plate and the hand screw should be tight.
6. Damaged arbor components should be replaced at once.

## Arbor Capacity Chart

Arbor Type	Operation	Height	Part Number	Capacity 4" Weights	Capacity 6" Weights	Self-Weight
Rod	Single Purchase	4'	007-15X04	504 lb	782 lb	56 lb
Rod	Single Purchase	5'	007-15X05	672 lb	1043 lb	63 lb
Rod	Single Purchase	6'	007-15X06	841 lb	1303 lb	71 lb
Rod	Single Purchase	7'	007-15X07	1009 lb	1564 lb	78 lb
Rod	Single Purchase	8'	007-15X08	1177 lb	1825 lb	85 lb
Rod	Single Purchase	9'	007-15X09	1345 lb	2086 lb	92 lb
Rod	Single Purchase	10'	007-15X10	1514 lb	2346 lb	99 lb
Rod	Single Purchase	11'	007-15X11	1682 lb	2607 lb	106 lb
Rod	Single Purchase	12'	007-15X12	1850 lb	2868 lb	113 lb
Rod	Single Purchase	13'	007-15X13	2018 lb	3129 lb	122 lb
Rod	Double Purchase 6-line	6'	008-615X06	841 lb	1303 lb	113 lb
Rod	Double Purchase 6-line	7'	008-615X07	1009 lb	1564 lb	120 lb
Rod	Double Purchase 6-line	8'	008-615X08	1177 lb	1825 lb	127 lb
Rod	Double Purchase 6-line	9'	008-615X09	1345 lb	2086 lb	134 lb
Rod	Double Purchase 6-line	10'	008-615X10	1514 lb	2346 lb	141 lb
Rod	Double Purchase 6-line	11'	008-615X11	1682 lb	2607 lb	148 lb
Rod	Double Purchase 6-line	12'	008-615X12	1850 lb	2868 lb	155 lb
Rod	Double Purchase 6-line	13'	008-615X13	2018 lb	3129 lb	163 lb
Rod	Double Purchase 8-line	6'	008-815X06	841 lb	1303 lb	119 lb
Rod	Double Purchase 8-line	7'	008-815X07	1009 lb	1564 lb	126 lb
Rod	Double Purchase 8-line	8'	008-815X08	1177 lb	1825 lb	133 lb
Rod	Double Purchase 8-line	9'	008-815X09	1345 lb	2086 lb	140 lb
Rod	Double Purchase 8-line	10'	008-815X10	1514 lb	2346 lb	147 lb
Rod	Double Purchase 8-line	11'	008-815X11	1682 lb	2607 lb	154 lb
Rod	Double Purchase 8-line	12'	008-815X12	1850 lb	2868 lb	161 lb
Rod	Double Purchase 8-line	13'	008-815X13	2018 lb	3129 lb	169 lb
FrontLoader	Single Purchase	6'	007-FL06-6	873 lb	NA	92 lb
FrontLoader	Single Purchase	8'	007-FL08-6	1164 lb	NA	112 lb
FrontLoader	Single Purchase	10'	007-FL10-6	1455 lb	NA	136 lb
FrontLoader	Single Purchase	6'	007-FL06-8	NA	1284 lb	105 lb
FrontLoader	Single Purchase	8'	007-FL08-8	NA	1712 lb	132 lb
FrontLoader	Single Purchase	10'	007-FL10-8	NA	2140 lb	158 lb
FrontLoader	Double Purchase	6'	008-FL06-6	873 lb	NA	120 lb
FrontLoader	Double Purchase	8'	008-FL08-6	1164 lb	NA	140 lb
FrontLoader	Double Purchase	10'	008-FL10-6	1455 lb	NA	164 lb
FrontLoader	Double Purchase	6'	008-FL06-8	NA	1284 lb	136 lb
FrontLoader	Double Purchase	8'	008-FL08-8	NA	1712 lb	163 lb
FrontLoader	Double Purchase	10'	008-FL10-8	NA	2140 lb	189 lb
Wire Guide	Single Purchase	4'	007-85X04	504 lb	782 lb	34 lb
Wire Guide	Single Purchase	5'	007-85X05	672 lb	1043 lb	37 lb
Wire Guide	Single Purchase	6'	007-85X06	841 lb	1303 lb	40 lb
Wire Guide	Single Purchase	7'	007-85X07	1009 lb	1564 lb	43 lb
Wire Guide	Single Purchase	8'	007-85X08	1177 lb	1825 lb	46 lb

# J-Guide System

---

## General Description

### **⚠ CAUTION**

- *The design and load capacity of mounting steel or other supporting structure must be suitable for all live and dead loads imposed by the guide system and associated hardware.*
- *The wall or structure which braces the guides must be rigid to keep the guides from buckling.*
- *The floor must be capable of supporting the weight of the guide system without deformation. If wood flooring is used, it should be solid or heavily blocked under the members to support the weight of the system without deflection.*

The J-Guide System consists of vertical, extruded aluminum J's placed so that the guide shoes on counterweight arbors and tension floor blocks ride in the slot formed between two adjacent members. Guides are usually spaced 6" (152 mm) or 8" (203 mm) between centers.

Top and bottom "Stop" battens are typically installed on the face of the guides to limit the travel of the counterweight arbor and floor block. An angle with punched holes or eye bolts may be provided to tie off the ends of double purchased hand lines.

Because extruded aluminum is very slick, steel guide shoes are provided.

## Inspection

Informal inspection should take place each time the system is used. Especially look for loose anchors and bolts. J.R. Clancy recommends a formal inspection annually under normal usage.

## Maintenance

1. Tighten and adjust loose bolts and fittings as necessary.
2. Damaged components should be replaced.
3. If a counterweight arbor is improperly loaded and permitted to run without control, it will hit a stop batten with considerable force. This force may be sufficient to:
  - a. Smash the wood bumper.
  - b. Bend the stop batten.
  - c. Shear off some of the bolts which mount the stop batten to the J-Guides.

Stop battens and fasteners are sized to sacrifice themselves, if necessary, in order to decelerate the running arbor without causing damage to the building or failure of other counterweight system components.

Any and all damage to rigging from a crash should be investigated by an expert and repaired or replaced before the system is put back into service.

### **NOTICE**

***DO NOT lubricate guides, arbor shoes or floor block shoes.***

# T-Guide System

---

## General Description

### **⚠ CAUTION**

- *The design and load capacity of mounting steel or other support structure must be suitable for all of the loads imposed by the tee guide system and associated hardware.*
- *The wall or structure that braces the tees must be rigid in order to keep the tees from buckling.*
- *The floor must be capable of supporting the weight of the tee system without deformation. If wood is used, it should be solid or heavily blocked under the tees to support the weight of the system without springing or deflection.*

The T-Guide system consists of vertical steel tees placed so that the slots in counterweight arbor and tension floor block guide shoes are captured between two adjacent tees. Standard T-Guide spacing is 6" (152 mm) or 8" (203 mm) between centers.

T-Guides are attached to "U" shaped brackets that are, in turn, attached to "wall battens" fixed to the wall or other structure with "wall knees".

Top and bottom "stop" battens are typically installed on the face of the T-Guides to limit the travel of the counterweight arbor and floor block. An angle with punched holes or eye bolts may be provided to tie off the ends of double purchased hand lines.

## Inspection

Informal inspection should take place each time the system is used. Especially look for loose anchors and bolts. Wenger Corporation recommends a formal inspection annually under normal usage.

## Maintenance

1. Tighten and adjust loose bolts and fittings as necessary.
2. Damaged components should be replaced.
3. If a counterweight arbor is improperly loaded and permitted to run without control, it will hit a stop batten with considerable force. This force may be sufficient to:
  - a. Smash the wood bumper.
  - b. Bend the stop batten.
  - c. Shear off the bolts that mount the batten to the T-Guides.
4. Stop battens are sized to sacrifice themselves, if necessary, in order to decelerate the running arbor without causing damage to the building or failure of other counterweight system components.
5. Any and all damage to rigging from a crash should be investigated by an expert and repaired or replaced before the system is put back into service.

### **NOTICE**

***Wenger Corporation DOES NOT recommend the lubrication of tees or arbor shoes. Lubricants tend to collect dirt and will hasten wear and increase friction against the guides.***

# **Index Lights**

---

## **General Description**

Index lights are intended to hang above a locking rail at the stage and/or gallery levels to provide a low level of directed illumination for the operators of the counterweight or rope rigging. Index light sections are generally joined together end to end to run the full approximate length of the locking rail or T-bar battery.

Index lights are available wired in one or two circuits. The second circuit will often contain blue colored lamps for use when the stage needs to be very dim and no offstage light must be visible.

## **Operation**

When working around index lights, use care not to bump them or lean scenery or curtains against them. Shocks will shorten lamp life and heat from the fixtures could damage some fabrics, etc.

## **Maintenance**

1. Replace lamps as necessary. Turn off fixtures and allow lamps to cool before changing any lamps.
2. Keep flammable objects away from fixture housings.

### **NOTICE**

***Use medium screw base, Type A, incandescent lamps, 40 watts maximum per lamp. Interconnect sections so the total wattage is within the capacity of a 15 ampere circuit.***

# **Floor Blocks**

---

## **General Description**

Blocks consist of a single grooved sheave mounted in a housing and installed on the tee guides, floor, or other support structure. Blocks support and change the direction of the counterweight arbor hand line. Some floor blocks are adjustable to compensate for stretch and shrinkage in the hand line due to loading and changing atmospheric conditions. Other blocks may incorporate rope locks or may be grooved for wire rope for use on motorized systems.

Floor blocks are only one part of a mechanical system of rigging. Consult an operations manual for a full description of the system operation.

## **Inspection**

1. Check housings for signs of bending, wear, loose or bent connections, and movement on the supporting structure. Check the supporting structure.
2. Sheaves should be checked for wear, checking in the grooves, and wear and tightness in the bearings and shafts. Check for chips or cracks that would indicate that the block has been shock loaded or abused in some other manner.

After a sheave has been subjected to any shock load it should be closely inspected for damage.

## **Maintenance**

1. Tighten and adjust loose fittings as necessary.
2. Check the tension in hand lines at least monthly when the system is new and during seasons of changeable weather. Adjust as necessary. If there is insufficient adjustment room in the floor block, the hand line should be retied at the arbor.

When the system is new the hand line will stretch. After a period of time it will probably be necessary to cut off excess rope but do not cut off too much because the rope will shrink in dry weather or when tension in the ropes are lessened. Manila ropes will change much more than synthetic lines.

3. Maintenance of sheaves consists of maintaining the bearings, keeping the grooves clean, and keeping the mounting tight. Bearings need to be kept clean, dry, lubricated and properly torqued. The standard bearing used in J.R. Clancy loft blocks is a sealed precision ball bearing. **Do not attempt to lubricate these bearings.** Ball bearings can be crushed if the shaft is over tightened, so only tighten the shaft nut until end play is removed.
4. Damaged blocks should be replaced.
5. **Do not over tighten guide wires on wire guided style arbors. The maximum recommended tension is 75 lb (34 kg). Safety wire all turnbuckles after adjustment.**



# Head and Loft Blocks

---

## General Description

Blocks consist of a single or multi-groove sheave mounted in a housing and installed on the block beams, stage gridiron or other support structure. Blocks support, and change the direction of, one or more lift lines. They are located between the head block or lifting mechanism and the pipe batten or other load.

Blocks are only one part of a mechanical system of rigging. Consult an operations manual for a full description of the system operation.

## Inspection

1. Check housings for signs of bending, wear, loose or bent connections, and movement on the supporting structure. Check the supporting structure.
2. Sheaves should be checked for proper fleet angles, wear and checking in the grooves, and wear and tightness in the bearings and shafts. Castings should be checked for chips or cracks that would indicate that the block has been shock loaded or abused in some other manner.
3. After a sheave has been subjected to any shock load it should be closely inspected for damage.

## Maintenance

1. Tighten and adjust loose fittings as necessary.
2. Maintenance of sheaves consists of maintaining the bearings, keeping the grooves clean, and keeping the mounting tight. Bearings need to be kept clean, dry, lubricated and properly torqued.
3. The bearing used in most 8" (203 mm) J.R. Clancy blocks is a sealed precision ball bearing. **Do not attempt to lubricate these bearings.** If ball bearings have been installed in a special block, they can be lubricated only if they are not sealed. Ball bearings can be crushed if the shaft is over tightened, so only tighten the shaft nut until end play is removed.

Tapered roller bearings are available as an option on most 8" (203 mm) blocks and standard for all others. The bearings are factory lubricated and should not be greased unless they become contaminated. If they do require lubrication, the sheave should be removed from its housing and the bearings cleaned. Only then should the bearing be pressure lubricated with a Lithium based bearing grease. Be sure to properly re-torque the bearings when putting the block back together. Tapered roller bearings should be tightened carefully until just tight; then back off the nut on the shaft until the sheave rotates freely without any end play.

4. **Do not over tighten** the center bolts on Series 19 blocks.
5. High strength strands in aircraft cable wear the grooves in cast iron sheaves over time. Even steel or Nylatron sheaves will be affected. For this reason grooves are manufactured slightly oversize so cables will fit in the grooves without pinching. As cable wears grooves they get smaller so wire rope check gauges are almost always made to the minimum groove size. If the gauge will not bottom out in the groove the sheave should be replaced. The following chart lists groove dimensions for new and worn sheaves.

Cable Diameter (inches)	New Groove		Worn Groove	
	inches	mm	inches	mm
1/8"	0.156	3.97	0.141	3.57
3/16"	0.219	5.56	0.203	4.76
1/4"	0.281	7.14	0.266	6.75
5/16"	0.344	10.3	0.328	8.33
3/8"	0.438	11.1	0.406	10.3

6. Replace damaged blocks.

# Mule Blocks

---

## General Description

Blocks consist of a single or multi-groove sheave mounted in a housing and installed on the loft block beams, stage gridiron or other support structure. Mule blocks support, and change the direction of, one or more lift lines. They are located between the head block or lifting mechanism and the loft block, pipe batten or other load.

Mule blocks are only one part of a mechanical system of rigging. Consult an operations manual for a full description of the system operation.

## Inspection

1. Check housings for signs of bending, wear, loose or bent connections, and movement on the supporting structure. Check the supporting structure.
2. Sheaves should be checked for proper fleet angles, wear and checking in the grooves, and wear and tightness in the bearings and shafts. Castings should be checked for chips or cracks that would indicate that the block has been shock loaded or abused in some other manner.
3. After a sheave has been subjected to any shock load it should be closely inspected for damage.

## Maintenance

1. Tighten and adjust loose fittings as necessary.
2. Maintenance of sheaves consists of maintaining the bearings, keeping the grooves clean, and keeping the mounting tight. Bearings need to be kept clean, dry, lubricated and properly torqued.

The bearing used in most 8" (203 mm) J.R. Clancy loft blocks is a sealed precision ball bearing. **Do not attempt to lubricate these bearings.** If ball bearings have been installed in a special block, they can be lubricated only if they are not sealed. Ball bearings can be crushed if the shaft is over tightened, so only tighten the shaft nut until end play is removed.

Tapered roller bearings are available as an option on most 8" (203 mm) loft blocks and standard for all others. The bearings are factory lubricated and should not be greased unless they become contaminated. If they do require lubrication, the sheave should be removed from its housing and the bearings cleaned. Only then should the bearing be pressure lubricated with Lithium based bearing grease. Be sure to properly re-torque the bearings when putting the block back together. Tapered roller bearings should be tightened carefully until just tight; then back off the nut on the shaft until the sheave rotates freely without any end play.

3. High strength strands in aircraft cable wear the grooves in cast iron sheaves over time. Even steel or Nylatron sheaves will be affected. For this reason grooves are manufactured slightly oversize so cables will fit in the grooves without pinching. As cable wears grooves they get smaller so wire rope check gauges are almost always made to the minimum groove size. If the gauge will not bottom out in the groove the sheave should be replaced. The following chart lists groove dimensions for new and worn sheaves.

Cable Diameter (inches)	New Groove		Worn Groove	
	inches	mm	inches	mm
1/8"	0.156	3.97	0.141	3.57
3/16"	0.219	5.56	0.203	4.76
1/4"	0.281	7.14	0.266	6.75
5/16"	0.344	10.3	0.328	8.33
3/8"	0.438	11.1	0.406	10.3

4. Replace damaged blocks.

# Capstan Hoist

---

## General Description

Capstan hoists assist rigging operators in controlling a counterweight system that is temporarily unbalanced during loading or unloading. The capstan hoist will hold a batten-heavy set in place with a rope from the arbor to the drum while the change is being made and can be used to haul the arbor down to a location where it can be reached to add weight to balance the system.

Motors, speeds, rigging, drum style and controls can vary widely, but there are only two basic types of capstan hoist systems in common use in the theatre. The fixed capstan hoist acts through a system of pulleys to raise and lower a load and its associated counterweight arbor and the Mobile Capstan Hoist rolls on casters to a position adjacent to the set to be assisted and locks into the reaction bar at that point. Capstan hoist systems consist of the hoist with its gearbox, motor brake, and capstan drum, plus a rope with an attachment hook at one end and any necessary pulleys. Controls are mounted on the hoist and include "Up" and "Down" pushbuttons and a foot-operated engagement switch that must be depressed in order for the hoist to run.

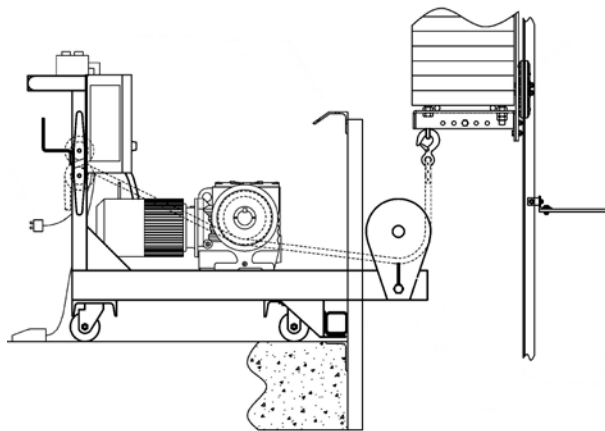

# Capstan Hoist (continued)

---

## Installation

### **⚠ WARNING**

***The design and load capacity of mounting steel or other support structure must be suitable for all of the loads imposed upon it.***

#### 1. Mounting

- a. The Mobile Capstan Hoist is a self-contained unit that requires no installation except for power and a reaction bar which must be mounted to the supporting structure, floor, or locking rail so that it is level and rigidly attached. The bottom of the bar should be located 1" (25 mm) above the finished floor to properly engage the lip on the front edge of the hoist. This is critical since the lip transmits the load from the hoist-hauling rope into the reaction bar and then into the building structure.
- b. Choose and install fasteners for the reaction bar that will hold the full capacity of the system and a suitable service factor.
- c. The floor must be hard and free of imperfections that will keep the hoist from holding the load and easily rolling into position along the reaction bar.
- d. Check the gearbox oil level and the breather, if one is present, for obstructions.
- e. Check the hoist capacity and speed to be sure they are proper for the intended use.

#### 2. Wiring

- a. The hoist is supplied with a type SO power cord and twist-lock connector. A mating receptacle must be supplied on the stage in a convenient location. The receptacle should be located to minimize any tripping hazard from the power cord. Check the motor name plate and compare the voltage and current requirements against the available power. Check wire and circuit breaker sizes.

**Note:** Standard voltage is 208 VAC, 60 Hz. Motor for this service will be supplied unless other instructions are received.

- b. The hoist must be wired and grounded in accordance with local code requirements.
- c. Wires in J.R. Clancy controls and motor starters use the following color code:

Color	Function
Black	High Voltage Power
Red	120 Volt Control
Blue	Low Voltage Control
Orange	Control Power from Remote Device
White	Neutral
Green	Ground

J.R. Clancy motor starters and controls are furnished with numbered screw terminals. All internal wires have wire numbers.

- d. Check the rotation of the hoist drum. Change any two power legs in the connector to reverse motor direction if necessary. Do not change wiring within the motor or starter.

## Capstan Hoist (continued)

---

### Operation

#### **⚠ WARNING**

***J.R. Clancy hoists are NOT designed to hold, raise, or lower people and should never be used in this manner.***

#### **⚠ CAUTION**

***NEVER operate rigging without first obtaining proper instruction and authorization.***

Capstan hoists need space on the stage or gallery for moving the hoist, for the operator, and to lay out the hauling rope for safe operation. If sufficient space is not available, do not use the mobile capstan hoist until the area can be made safe.

1. The first step in operating any hoist is to become familiar with its current status and method of operation. Check the load and look for places where the load could foul during its travel. Check the direction of drum rotation when the "Up" or "Down" buttons are pushed.
2. Check to be sure that the hoist is plugged in, that the power is turned on, and that the power cord is safe and does not interfere with the movement of personnel or the load
3. Move the hoist to the desired location at the locking rail and engage the lip on the front of the hoist under the reaction bar on the locking rail. Locate the foot switch in a convenient spot on the floor but where it will not interfere with free movement of the hauling rope or operators.
4. Counterweight arbors which are manufactured for use with a capstan hoist will have a large eye on the bottom of the arbor or one of the arbor rods. The haul line should be hooked to this eye and carefully run around the integral snatch block to the hoist where it is wrapped two or three turns around the capstan drum so that it will pull in the correct direction when the hoist is turned on.

#### **⚠ WARNING**

***Lay out excess rope so it will not snarl or snag on any obstruction or pull the operator or bystanders into the capstan hoist or arbor.***

5. Hold the rope after it is wrapped around the drum and push the button for the desired direction of travel while depressing the foot switch. It isn't necessary to hold the "Up" or "Down" buttons, but it is necessary to keep the foot switch depressed. The hoist will not start, or continue to run unless the foot switch is depressed.
6. Pulling the rope will tighten it against the rotating drum and cause the rope to move the load. The load will slow down if the operator eases the tension in the rope, permitting it to slip against the rotating drum. If tension is eased completely, the rope will lose contact with the capstan drum and the load will fall regardless of the direction of the drum rotation. The rope must be tied off to the cleat on the hoist frame before tension is released.
7. The operator must constantly watch the progress of the load being raised or lowered. If the operator cannot see the load a safety man should be stationed to watch and report its progress to the operator.
8. When the motor is turned off the brake is automatically applied at the same time but the load will not stop instantly. The load will continue to travel until the capstan drum decelerates to a stop. The distance traveled will depend upon the condition of the brake, the size of the load and whether the load is being raised or lowered. If you are attempting to stop at a certain point, plan ahead.

## **Capstan Hoist (continued)**

---

### **Operation (continued)**

#### **⚠ WARNING**

***NEVER operate capstan hoist with the rope lock engaged. Damage to equipment or possible injury could result. Follow instructions for handling counterweight when loading and unloading arbors.***

9. If fine adjustment is needed, stop the hoist with the load higher than desired and then ease rope tension and allow the load to lower into place. Finally tie off the rope to hold the load in place.

### **General Precautions**

1. Keep people out from under moving equipment.
2. Look for potential problems, such as lift lines or curtains which could foul a batten.
3. Make sure that proper operational and safety procedures are followed.
4. During set-up, operate only one set at a time. Identify any potential interferences or other problems.

### **Inspection**

1. All equipment requires periodic maintenance and inspection to insure long life and trouble-free operation. Inspect on a scheduled basis and keep records. These will provide information on length of service and upon any changes in performance which might indicate wearing parts. The frequency of inspections depends on the usage and severity of the operating conditions but at minimum look for problems (crossed cables, loose fittings, obstructions, etc.) once a month and conduct a full visual inspection and lubrication annually. In addition to inspections and maintenance by the in-house staff, Wenger Corporation recommends a periodic safety inspection by a professional rigging firm.
2. Before performing any inspection or maintenance on powered equipment, it should be removed from use and disconnected or locked out.
3. Check hauling rope and end hook for any sign of wear or abrasion. Repair or replace when necessary.
4. Inspect the power and foot switch cords and connections on a regular basis for signs of abrasion, crushing or loose connections. Repair or replace when necessary.

## Capstan Hoist (continued)

---

### Maintenance

See data sheets from component manufacturers for additional maintenance instructions or information. See the following recommendations for routine maintenance:

1. Lubrication
  - a. Motors used in J.R. Clancy products are sealed so they never need lubrication.
  - b. Check gearbox oil level and quality frequently. Add oil as needed and change if contaminated. Replace after two years or 5,000 hours of use. If using synthetic oil, change after four years or 40,000 hours.
2. As brake disks wear they will no longer stop the motor as quickly as when new. Follow the manufacturer's specific recommendations for adjustment or replacement of brake calipers.
3. Tighten, if needed, all couplings, screws, etc.
4. Clean motor fans to keep them from overheating.
5. Motor Starters
  - a. Components in starter cabinets should be checked two or three times per year. Be sure the power is off before opening the control cabinet for routine maintenance. Excessive dirt should be vacuumed from the cabinet interior to prevent contact arcing and premature relay failure.
  - b. Fuses will occasionally fail from age or build up of stress. Replace failed fuses only with fuses of the same type and rating. Be sure to check the rating on the failed fuse and the label at the fuse block or shop drawing. If the fuse has the wrong value, replace it with a fuse of the correct type and rating. If a fuse fails a second time, look for a short circuit or defective component. The following chart lists fuses commonly used in J.R. Clancy starters. Be sure to check the rating.

Device	Brand	Type	Amps
Transformer Primary	Gould	ATQR	1 - 1/8
CLASS CC	Buss	FNQR	
(Time Delay)	Littlefuse	KLDR	
Transformer Secondary	Gould	TRM	6/10
CLASS CC	Buss	FNM	
(Time Delay)	Littlefuse	FLM	
Power Line	Gould	ATDR	
CLASS CC	Buss	LPCC	
(Time Delay)	Littlefuse	CCMR	
CLASS J	Gould	AJT	
	Buss	LPJ	
	Littlefuse	JTD	

6. Parts Lists

**Consult Wenger Corporation shop drawings for listings on specific components.**