

# Cross Grid Connector

- Provides rigid, low-profile connections for assembling pipe grids of 1-1/2" (38 mm) Schedule 40 pipe.
- Black, powder-coated 1/8" (3 mm) steel plates are supplied with 3/8" (9.5 mm) Grade 5 bolts and nuts.
- Pipes can be added or removed in place, without sliding them in from the ends.
- Half of the assembly can also be used to secure a 1-1/2" (38 mm) Schedule 40 pipe to any flat surface.

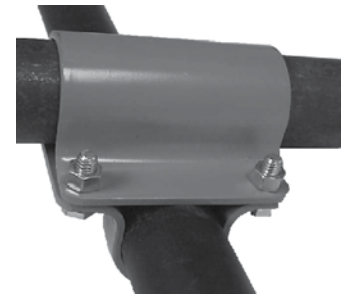

**Cross Grid Connector**  
015-100

## Dimensions

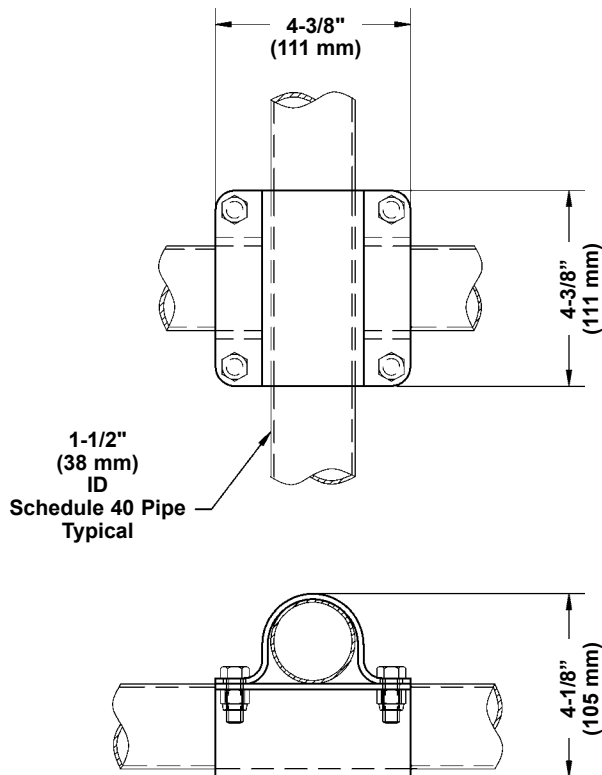

## Order Information

Number	Description	RWL	Weight
015-100	Cross Grid Connector	1500 lb (680 kg)	2 lb (0.9 kg)

**RWL:** RWL is maximum load that can be applied to the cross grid connector which is in "like new" condition and has been properly installed, maintained, and operated.



© 2018 Wenger Corporation  
USA/2018-11/W

