

STANDARD TOLERANCES		MACHINING: 1/X ±1/64"		WELDING: DIMENSION 0 ±1/16"	
UNLESS NOTED OTHERWISE		.XX ±.010"		DIMENSION 10' ±1/8"	
		.XXX ±.003"		ANG. ±1/2"	
FINISH: TO BE SPECIFIED					
NUMBER	DATE	DRAWN	REVISIONS		
0	---	AWG	ISSUED FOR CONSTRUCTION		

NOTE:
DISCONNECT MOUNTED ADJACENT
TO AND SUPPLIED BY OTHERS

SERVICE:
120VAC, 1Ø, 60Hz, 15A, WITH GROUND
BY OTHERS

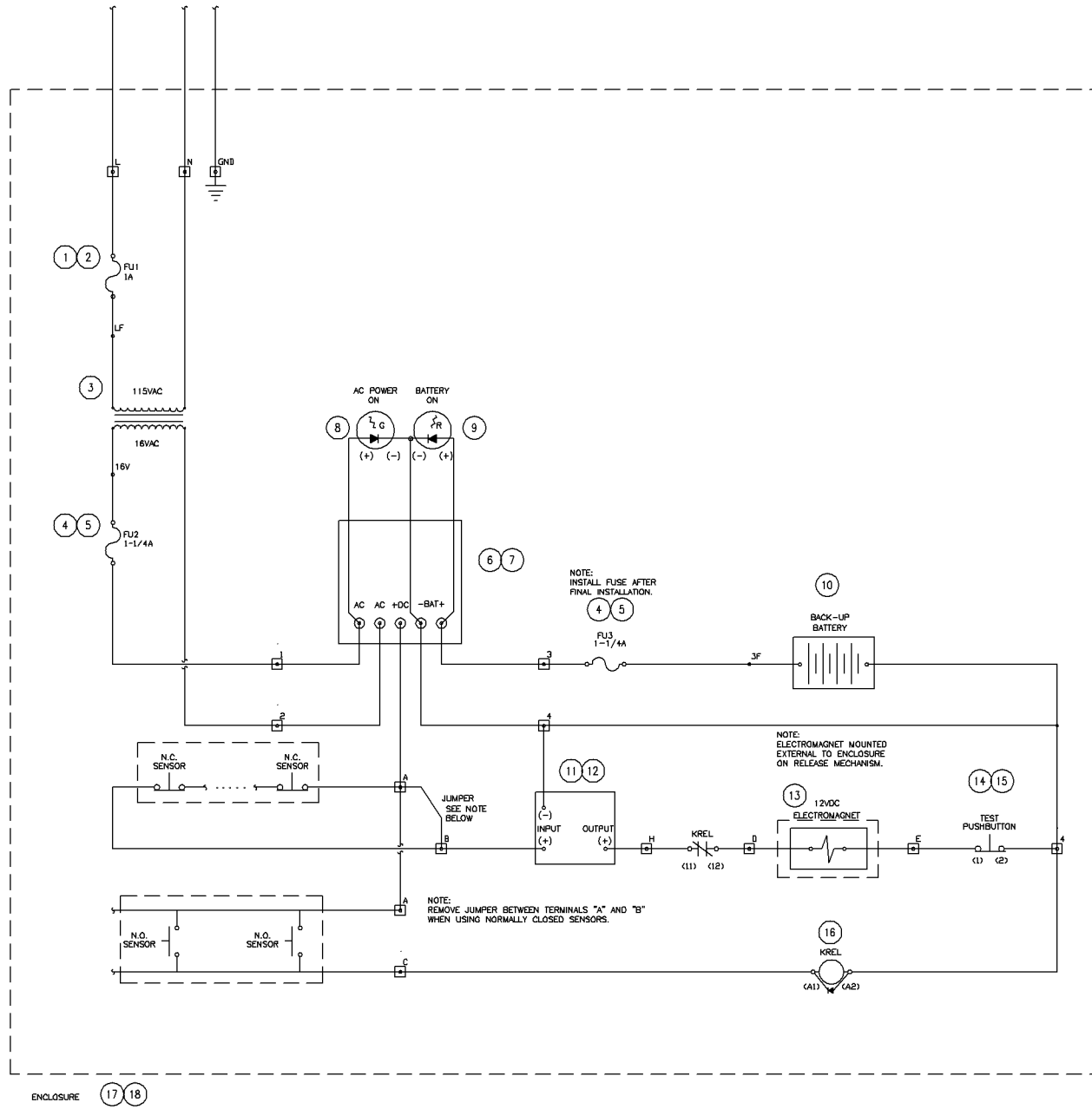

□ SYMBOL DENOTES TERMINATION IN CONTROL PANEL
○ SYMBOL DENOTES WIRE IDENTIFIER IN CONTROL PANEL

18	ENCLOSURE BACK PANEL: VYNCKIER MP1210A	1	1
17	ENCLOSURE: 12"Hx10"Wx5"D; HINGED ON SHORT SIDE VYNCKIER VJ1012HW	1	1
16	RELAY-SPDT, 12VDC: PLC-RSC-12DC/21 PHOENIX 29 66 91 9	1	1
15	PUSHBUTTON- FLIP COVER: ALLEN-BRADLEY 800A-N42	1	1
14	PUSHBUTTON- SQUARE HEAD IND, INC: ALLEN-BRADLEY 800A-M2F	1	1
13	ELECTROMAGNET: 12VDC, 5WATT, 44LB. HOLDING A.P.W. Co. 607 R 1.37	1	1
12	CARD HOLDER W/DIN MOUNT FEET ABB L9911010100, W/(1EA) L99110300000	1/1	1/1
11	LOW POWER DISCONNECT: ALTRONIX LPD	1	1
10	BATTERY: 12VDC SEALED LEAD-ACID YUASA: NP 1.2-12	1	1
9	LED: RED 24V TELEMECANIQUE XVL A334	1	1
8	LED: GREEN 24V TELEMECANIQUE XVL A333	1	1
7	CARD HOLDER W/DIN MOUNT FEET PHOENIX UM 72 PROFIL CM W/UM 72-FE	1/1	1/2
6	POWER SUPPLY/CHARGER: 12VDC ALTRONIX: AL624	1	1
5	FUSE: LITTELFUSE 3121.25 1 1/4A	1	2
4	FUSE BLOCK: ALLEN-BRADLEY 1492-H6, W/1492-N37	1/1	2/1
3	TRANSFORMER: HAMMOND 32.5VA, 166L16	1	1
2	FUSE BLOCK: CLASS CC, FINGER SAFE LITTELFUSE LPSC001	1	1
1	FUSE, 1AMP: LITTELFUSE KLDR-1	1	1

ITEM NUMBER	DETAIL SHEET	DESCRIPTION OR PART NUMBER	QUANTITY PER ASSEMBLY	TOTAL THIS SHEET
PROJECT		016-970 SURE GUARD II		
ARCHITECT		TITLE		
CONSULTANT		SCALE NONE	SURE GUARD II	STD
CONTRACTOR		DRAWN AWG	FILE NAME	SALES NO.
		DATE 1.3.AND.06	-	
		CHECKED		
		DATE		

THIS DRAWING IS THE PROPERTY OF J.R. CLANCY INC. ANY USE AND/OR REPRODUCTION OF THIS DRAWING OR THE DESIGNS CONTAINED HEREIN, WITHOUT WRITTEN CONSENT OF J.R. CLANCY INC., IS PROHIBITED. J.R. CLANCY INC. IS NOT RESPONSIBLE FOR THE UNAUTHORIZED USE AND/OR ALTERATION OF THIS DRAWING OR THE DESIGNS CONTAINED HEREIN. THIS DRAWING IS SUBJECT TO REVIEW AND APPROVAL BY THE PROJECT'S ARCHITECT AND/OR ENGINEER AND IS INCIDENTAL TO J.R. CLANCY'S MANUFACTURING AND/OR INSTALLATION OF THE ITEM(S) REPRESENTED HERE. COPYRIGHT 2006 J.R. CLANCY INC.

SureGuard[®] II

Installation & Schematic

The Sure-Guard II allows smoke detectors, rate of rise detectors or other electrical signals to deploy the fire safety curtain in an emergency. In response to these signals, the Sure-Guard II's electro-mechanical mechanism releases tension in the release line, allowing the fire safety curtain to deploy. The release mechanism may be located at any point along the release line and does not interfere with other deployment mechanisms.

The Sure-Guard II contains an integral battery and charger to provide emergency power for approximately 30 minutes in case of interruption to normal power. A test switch on the cover allows the fire safety curtain and control to be tested. After operation, the Sure-Guard II system and release line must be reset. See item 4 in the installation instructions.

WARNING

Improperly installed rigging equipment may cause serious injury.
Follow all instructions in this manual and project drawings.

NOTICE

You are responsible for providing proper installation of this equipment.

You are responsible for providing the buyer with all relevant safety manuals, warning signs, training and instructions regarding potential hazards, installation, proper operation, and proper maintenance of the goods.

INSTALLATION

1. The SureGuard II should be installed approximately 8' above the floor so that it is less likely to be hit or tripped by accident. The dual pulley must be in line vertically with the fire line. The channel supporting the dual pulley and magnet may be unbolted and reversed so that the dual pulley is on the opposite side of the unit. Mount the unit to the wall using 5/16" or 3/8" mounting hardware.
2. Electrical installation requirements are shown on the label inside the unit. If any Normally Closed sensors are used, remove the jumper between terminals A & B and connect the NC sensors in series between terminals A & B. Normally open sensors (Rate of Rise Detectors, Smoke Detectors, etc.) are connected in parallel between terminals A & C.
3. Connect the battery by installing fuse FU3. Before putting this unit in service, connect line power for 24 hours to fully charge the battery. Power to this unit should be left on at all times except during testing or maintenance. The fire curtain should be lowered before power to the unit is turned off.
4. After the unit is installed and wired, feed the fire line around one of the sheaves in the dual pulley, then around the swivel eye pulley, and back around The other sheave in the dual pulley as shown in the photo. The swivel eye on the small pulley is put over the hook on the trip arm and the arm is placed in contact with the electromagnet. The Sure-Guard II must be powered before the arm and fire line will stay engaged.
5. To ensure proper operation, the tension in the fire line must be set between 5 & 40 pounds (3 & 18 Kg). See the fire curtain system drawings for additional details on installing the fire line and rigging

When properly connected the LED's indicating the presence of 120 VAC power and the status of the battery power will be illuminated.

For connection to building fire alarm systems, consult the factory.

PROBLEM	POSSIBLE CAUSE	REMEDY
Green light off	No power to control box	Turn on switch or circuit breaker at power source.
	Blown fuse	Check fuses FU 1 & 2. Replace fuse. Check for possible short circuit.
Red light off	Battery not charged	A new battery will take about 24 hours to fully charge after installation.
	Battery not connected	Check the wire connections on the battery to be sure it is fully engaged
	Defective control board	Unplug the battery and check to see that voltage is present at the receptacle. If not, replace control board.
Trip arm will not stay engaged	Excessive pull in fireline	The maximum permissible pull on the hook is 50 pounds. Note that the maximum allowable tension in the fireline is 40 pounds.
	Normally closed devices missing, defective, or improperly wired	Install or repair devices. Check wiring.
		Install a jumper between terminals A & B if no normally closed devices are installed.
	Normally open devices defective or improperly wired	Install or repair devices. Check wiring.
Battery worn out or defective	Disconnect the battery and check output voltage. It should be 11 – 13 VDC, otherwise replace the battery.	

PROBLEM	POSSIBLE CAUSE	REMEDY
		Reconnect the battery, confirm that the electromagnet is installed, and check the voltage between terminals D & E. If the voltage is 0 VDC, replace the battery. A new battery will take about 24 hours to fully charge after installation.
	Defective Electromagnet	If 12 VDC can be measured between terminals D & E with the electromagnet properly installed, it is defective and must be replaced.



© 2006 J. R. Clancy

P08-0603

SureGuard II™

S/N _____

⚠ CAUTION



HAZARDOUS VOLTAGE.
Remove power before servicing.
Read instructions before installation or maintenance.

INSTALLATION INSTRUCTIONS

- Use Copper Wire Only, 60°C Torque Terminals 4.4 - 7.1 LB.IN.
- Connect battery by installing FU3.
- Before putting this unit in service, connect line power for 24 hours to fully charge the battery. Power to this unit should be left on at all times except during testing or maintenance.
- When using normally closed devices remove jumper between terminals 'A' and 'B'.



1-800-836-1885 ■ www.jrclancy.com

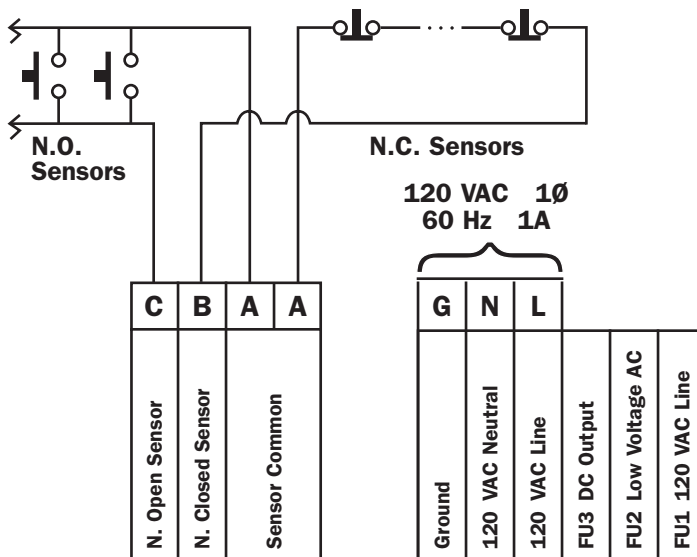

FU1: Time Delay 1A, 600V

Littelfuse KLDR-1 or Equal

FU2 & FU3: Fast Acting 1-1/4A, 250V

Littelfuse 312 1.25 or Equal

Enclosure = Type 1

Output to Magnet = 12VDC, 5 Watt

Disconnecting means provided by others.

See J.R. Clancy Drawing #SureGuard II.

MANUFACTURED FOR J.R. CLANCY BY ROWE TECHNICAL SERVICES, INC., 306 LAROBARDIERE ROAD, MEXICO, NY 13114

L24-0601

©2005 J.R. CLANCY, INC.