



Contents

Important Safety Information	2	Inspection and Maintenance Procedures (continued)	
Product Use Requirements	3	Motor and Gear Reducer	7
Maintenance Schedule	3	Secondary Load Brake	8
Replacement Parts	3	Manually Releasing the Hoist Brakes	10
Recommended Tools	3	Controls Enclosure	10
Inspection and Maintenance Procedures	4	Circuit Protection and Controls Electronics	11
Beam Clamps and Machinery Frame	4	Limit Switch Settings	12
Blocks and Wire Rope	4	Warning Signs and Operational Instructions	15
Guide Rollers	6	Decommissioning and Disposal	15
Drum Screw	6	Titan Hoist Maintenance and Inspection Log	16

Visit the Titan Hoist web page at jrclancy.com for more information.

- Note:** Please read and understand these instructions before using or setting up.
- Note:** Review all of the Installation Drawings and Reference Drawings.
- Note:** If you need additional information, contact JR Clancy using the information below.

Important Safety Information



- For any non-standard Titan Hoist there may be supplemental documentation for hoist maintenance. This documentation can be located at the end of the manual and/or on the hoist drawing(s).
- The procedures in this manual are for use by qualified personnel (furthermore all Qualified Person(s) or Personnel are as defined by ANSI E1.6-1-2019, Entertainment Technology-Powered Hoist Systems, section 3.22) only. If you are not qualified, contact the company that installed your system or JR Clancy to find the nearest service provider.
- The Titan Inspection Checklist must be completely filled out and a copy returned to JR Clancy as proof of initial and subsequent annual inspections. Proof of inspection may be required to activate and maintain the warranty period for this product.
- All users must be aware of maintenance requirements and warned of the associated hazards. Keep a copy of this manual available along with all other product documentation for future reference.



⚠ WARNING

Improper installation or maintenance can cause the machine to fail.

- Hoisting machines impose significant loads on the structure to which they are attached. It is the responsibility installer or service provider for verifying that a qualified person (as noted in ANSI E1.6-1-2019, section 3.22) has determined that this structure can withstand the loads.
- Equipment must be installed and maintained by qualified personnel.
- Annual inspection and maintenance of this product is required. Some applications may require more frequent inspection and service.
- Do not substitute or modify components provided with this equipment.
- Do not exceed the recommended working load of the hoist. It varies by model and is marked on the Identification Label on the hoist.
- Do not exceed lift line capacity on any one wire rope:
 - 1/4" wire rope capacity: 750 lb [340 kg]
 - 3/16" wire rope capacity: 500 lb [230 kg]
- Do not lift or support people or animals.
- Hoist weight varies depending on specifications and is listed on the hoist assembly drawing. Use appropriate handling equipment and safe work practices.



⚠ DANGER

Electrocution Hazard

- Remove power before opening electrical panels.
- Electrical equipment must be installed by qualified electricians.



⚠ WARNING

Moving parts can cut or crush.

- Keep body parts away from machinery in motion.
- Remove power source before working on machinery.
- Machines with moving parts within 106 inches (2.7m) vertically from the floor and less than 60 inches (1.5m) horizontally from a safety barrier must be fitted with machine guarding per ANSI E1.6-1-2019, section 6.7. Guards must be in place during use.

Product Use Requirements

- Installation of this equipment must comply with local building codes.
- Equipment must be installed according to manufacturer's drawings. Individual component information is listed in the bill of materials of these drawings.
- Titan hoists must be inspected by qualified person(s) (as noted in ANSI E1.6-1-2019, section 3.22) every year, or more frequently depending on use and local, state, and federal laws.
Do not install in locations that prohibit access or prevents removal of any machine guarding.
- Titan hoists are designed for indoor use only in buildings with temperatures between 50° and 100°F (10°- 38°C).
- Do not expose machines to rain or extreme humidity.
- Dimensions and weight of Titan hoists vary from project to project. Consult project drawings.
- The recommended working load and duty cycle of each machine is marked on the Identification Label on the controls enclosure. Do not exceed.
- The hoist machinery must be protected from oil, dust and other contaminants.

Maintenance Schedule

Notice: This machinery must be inspected and maintained annually by qualified person(s) (as noted in ANSI E1.6-1-2019, section 3.22). Proof of inspection is required to maintain warranty status.

Annual inspection and operator training is required to maintain the warranty period specified in your information binder, and proof of annual inspection and training may be required to obtain warranty service. Certain applications may demand more frequent inspections and maintenance. It is the responsibility of the user to monitor the machinery and adjust the maintenance schedule accordingly.
Be aware of government regulations concerning the inspection of hoisting equipment.

Replacement Parts

Lubricants and other components that can be procured locally are fully specified in the appropriate section of this manual. Use only the specified type and grade of materials.
Contact your local JR Clancy dealer to obtain any parts not listed in this document.

Recommended Tools

The following tools and materials may be used in this manual and during annual inspections and regular maintenance. This list is not exhaustive, but can be used as a starting point for selecting the proper tools.

- Appropriate personal protective equipment
- 7mm hex nutdriver
- 7/16", 1/2", 9/16", 3/4", 10 mm open-ended box wrenches
- 3/4", 17mm socket wrenches
- Torque wrench
- Wire rope termination tools, as necessary
- Castrol Inc Pyroplex Red NLGI #2 High Temperature Grease
- Portable grease pump
- Feeler gauge set (english and metric)
- 4mm hex (allen) key

Inspection and Maintenance Procedures

Beam Clamps and Machinery Frame

1. Make sure a clamp has been welded to hoist backbone, then the remaining are secured using two U-Bolts provided by JR Clancy. Reference project drawings
2. Check to make sure there is no loose hardware or materials set on top of hoist frame.

Blocks and Wire Rope

1. Check the fleet angle on all sheaves.

⚠ WARNING

Keep body parts away from the machinery in motion.

2. Remove any covers from the machine and observe the machine while running. Listen for the sound of wire rope that might be rubbing against the machine or other ropes. Adjust loft or remote head block(s) if necessary, to eliminate any rubbing.
3. Observe the machine while stationary. Inspect the fleet angle of the rope with respect to the drum grooves as seen in Figure 1. If fleet angle is not acceptable, dead wraps must be added or removed using the replacement procedure below.
4. Test the operation of the machine. Wire ropes entering the drum should not rub on the drum wraps or skip drum grooves.

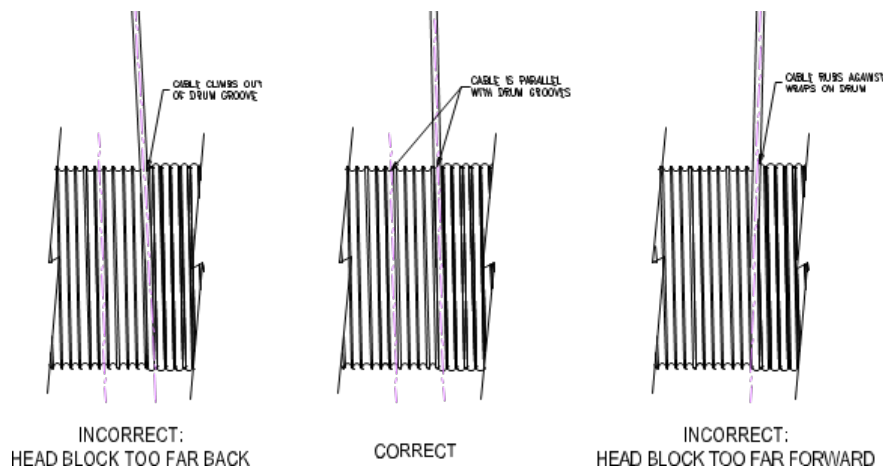

Figure 1: Inspecting the Fleet Angle at the Drum

Inspection and Maintenance Procedures (continued)

Blocks and Wire Rope (continued)

5. Make sure the wire rope is free of kinks, distortions and broken wires. Titan hoists are to be used with 1/4" diameter 7x19 Small Diameter Specialty Cord as defined by ASTM standard A1023. For additional wire rope options see addendum A. Consult hoist drawings to determine the rope size for a particular machine. The correct size rope must be used.



6. Replace wire ropes as necessary using the following procedure:
- Move the load to a location where it can be secured using other rigging e.g. to another batten or to the building structure.
 - Rotate the drum so that the cable termination clips are visible.



- Secure the load and remove the damaged wire rope.
 - Reeve the end of the new rope through the loft blocks and to the Titan.
 - Reeve the rope through the Titan head block being careful to stay below the sheave spacers.
 - Wrap the wire rope around the drum enough times to match the number of standing wraps on the other lines of the hoist. Note that a minimum of three wraps must be maintained on the drum when the machine is at the lowest limit of travel.
 - Make sure the rope lays properly into the grooves on the drum. Insert rope between drum and rope clip, leaving 0.50" to 0.75" exposed past the clip.
 - Tighten the clip by tightening each bolt to a minimum torque value of 20 in-lb.
 - Prior to terminating the lift lines, inspect the reeving and check the following:
 - Wire ropes must lie smoothly in the grooves of the drum.
 - Double check that the wire ropes are reeved properly through the blocks.
 - While pulling wire rope tight, check the fleet angle on the drum. See Figure 1.
 - Cut the lines to length and terminate at the batten.
 - Install a trim chain, turnbuckle, or other rated load leveling device on each lift line connection.
 - Use terminating hardware that is properly rated for the load. Follow hardware manufacturers' instructions carefully, e.g. use inspection gages for swaged sleeves.
 - Swaged sleeves are recommended for most installations. If wire rope clips are used, annual maintenance must include checking the clip nuts with a torque wrench.
7. Inspect any wire rope clips that may be used on the system and use a torque wrench to make sure the nuts are tightened according to the manufacturer's recommendations.
8. Visually inspect swaged (Nicopress or similar) terminations to look for signs of damage or overstress. At least 1/16" of the dead end of the wire rope should be protruding from the swaging sleeve.
9. Inspect all wire rope thimbles for deformation or other damage.
10. Inspect all other components used to attach the loads to the Titan lift lines.

Inspection and Maintenance Procedures (continued)

Guide Rollers

1. Make sure that there is a roller on every wire rope. Note the position of the rollers in Figure 2.
2. Each roller must be secured to the hoist frame with a M6X20 T-bolt, lock washer and a hex nut. Check fasteners are tight, and none are missing.
3. Make sure rollers are aligned with the wire rope as shown in Figure 2.
4. Observe the surface of the rollers to look for abrasion or other damage
5. Observe the machine while operating and make sure that all rollers are turning.

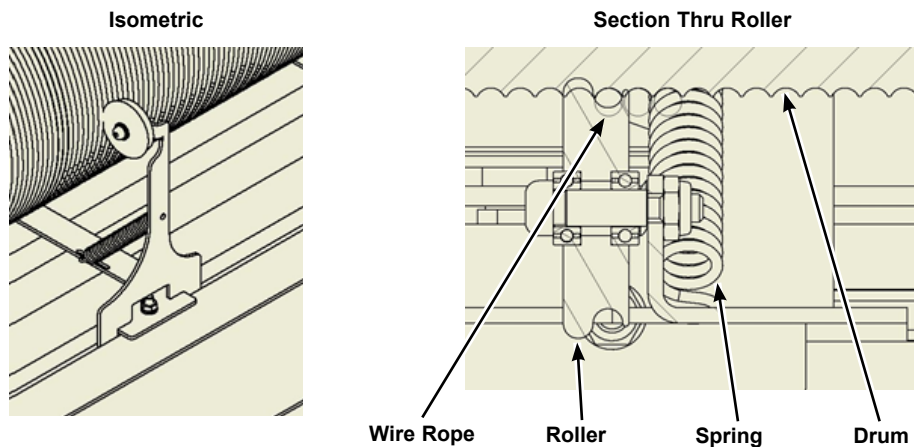

Figure 2: Guide Roller

Drum Screw

1. Examine the Drum Screw as seen in Figure 3.
If the grease is contaminated with debris or excessive dust, wipe all the contaminated grease off.
Look for debris or other signs of damage to the nut inside the drum that runs on the screw.
2. Lubricate the screw with a thin even film of Castrol Inc Pyroplex Red NLGI #2 EP High Temperature Grease.
Contact JR Clancy if you cannot locate a dealer with the specified grease in your area.
3. Observe the machine in operation through the entire range of motion to make sure the drum moves smoothly.

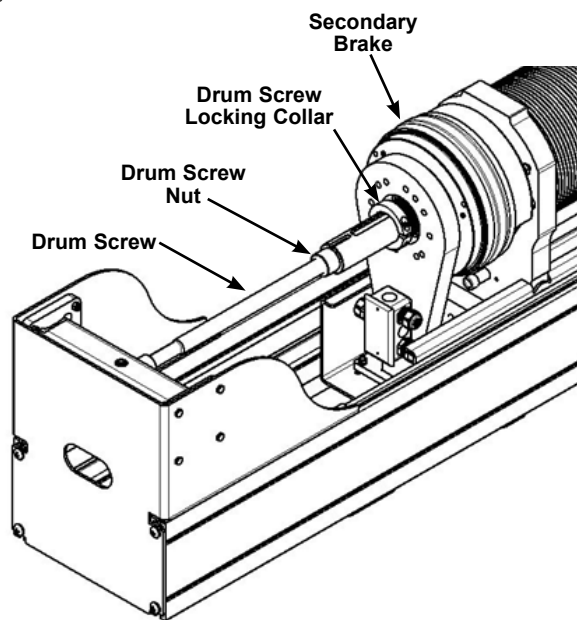

Figure 3: Drum Screw

Inspection and Maintenance Procedures (continued)

Motor and Gear Reducer

1. Observe the machinery while raising the load, the brake on the electric motor should engage and stop the load before the secondary load brake engages. The load should stop quickly and without any back-winding.

If the load backwinds, or if the load brake is engaged under these circumstances, the electric motor brake should be serviced. Contact the JR Clancy factory.

2. Check the gear reducer oil level.

The gear reducer oil must be replaced every two years or analyzed annually by a commercial laboratory to ensure that the oil properties and contamination levels are acceptable.

3. Figure 5 shows the drain plug and fill levels for the machines based on mounting position. Any oil added to the reducer must match the manufacturer and type marked on the reducer label that is fastened directly onto the side of the gear case. Note that bearings inside the electric motor are lifetime lubricated and sealed and do not require periodic lubrication.
4. Inspect for any loose fasteners and retighten as necessary.

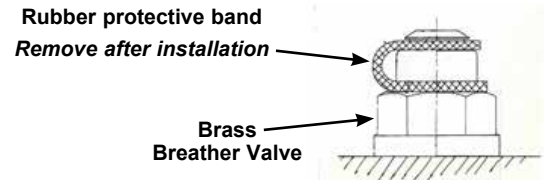

Figure 4: Reducer Breather Valve With Protective Band







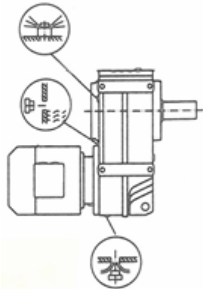

Mounting Position	Lubrication Ports	
 <p>Underhung Hoist Reducer Position M3</p>		
 <p>Upright Hoist Reducer Position M1</p>		
 <p>Wall Mounted Reducer Position M2</p>		
 <p>Fill Level</p>	 <p>Breather Valve</p>	 <p>Drain Plug</p>

Figure 5: Reducer Lubrication

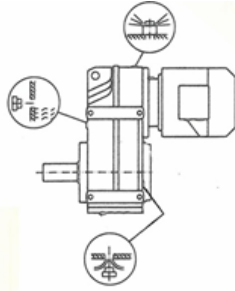
Inspection and Maintenance Procedures (continued)

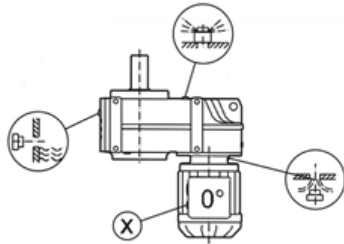
Secondary Load Brake

The Titan is equipped with two brakes: a primary motor brake and an electrically operated secondary load brake.

⚠ WARNING

The primary and secondary brakes must be properly adjusted or the load can fall if the hoist loses power.

The secondary brake is calibrated at JR Clancy, but the following procedure should be used to check the brake once it is installed. See Figures 6-8 on the following page.

1. Locate the three locking nuts on the face of the brake.
Confirm that all three nuts are in place.
2. Locate the manual release bolt holes in the face of the brake.
Confirm that the release bolts have been loosened.
3. Slide the protective rubber boot back to expose the air gap between the brake magnet and the armature assembly. The edge of the paper disk will be visible.
4. Check the gap between the paper disk and magnet at a minimum of three locations around the brake.
This gap should be set to 0.9 mm (0.035 inches).
A mechanic's feeler gauge is recommended to inspect this gap.
5. Adjust the nuts on the face of the brake as necessary to maintain the proper clearance.
The nuts must remain fully threaded on the studs at all times.
6. Replace the rubber boot around the brake when adjustment is complete.

Inspection and Maintenance Procedures (continued)

Secondary Load Brake (continued)

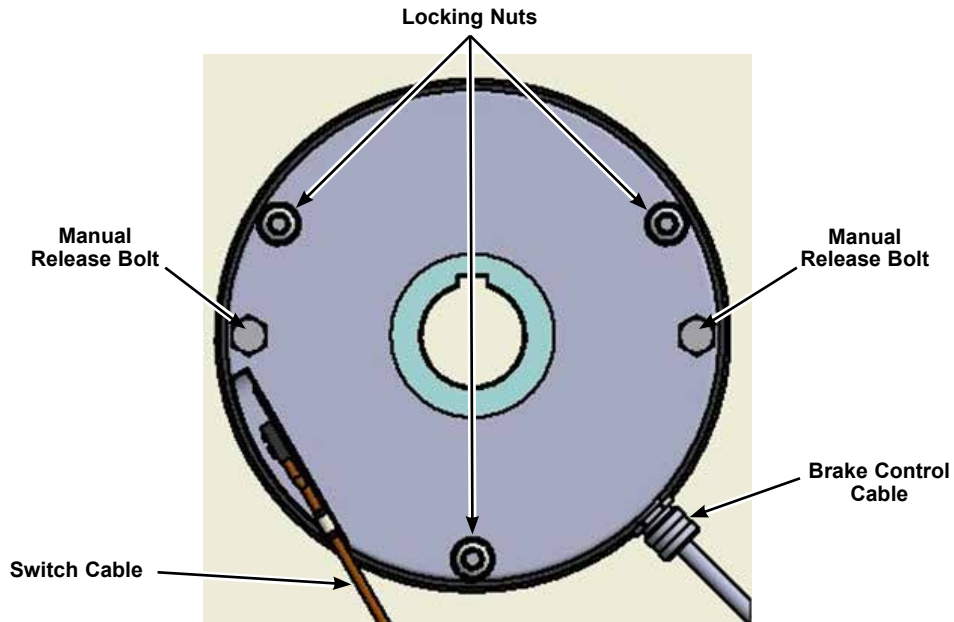

Figure 6: Secondary brake bolt locations

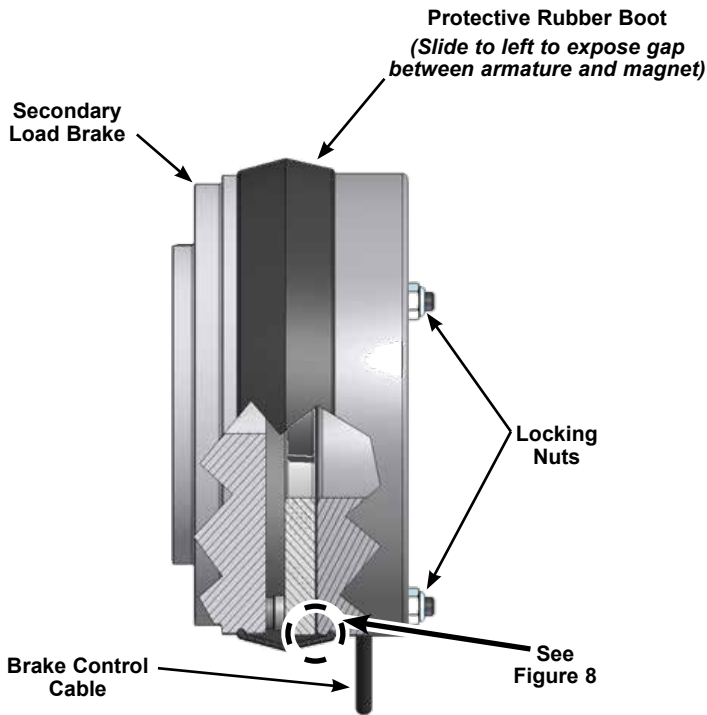

Figure 7: Side view of brake with rubber boot

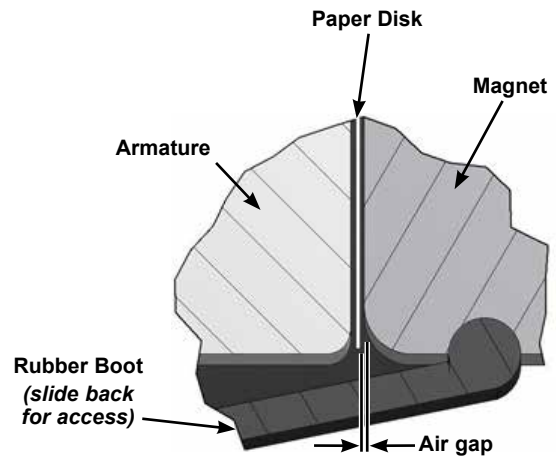

Figure 8: Detail view of brake air gap

Inspection and Maintenance Procedures (continued)

Manually Releasing the Hoist Brakes

It is possible to manually release the hoist brakes for testing or maintenance.

⚠ WARNING

Releasing either brake can cause the load to fall. This procedure is for use by qualified personnel only. Secure the load and/or keep the area below the hoist clear when working on the hoist brakes.

⚠ DANGER

Releasing both brakes will cause the load to fall. Remove or secure the load on the hoist before releasing both brakes.

To release the motor brake:

1. Locate the threaded manual brake release handle. It is clipped to the fins of the motor or screwed into the reducer adjacent to the encoder.
2. Locate the matching threaded socket in the fan shroud of the motor and screw in the release handle.
3. Pull the release handle towards the back of the motor shroud until resistance increases sharply and then slightly further to release the brake. Note that only after the resistance increases sharply will the brake be released. Take care to not bend the release handle.
4. The brake will reengage when the handle is released. Replace the brake handle in its storage position on the motor fins or gear case after work is complete. Servo motors will have the release handle already attached.

To release the secondary brake

1. Use a wrench to alternately and evenly tighten the two bolts about ½ turn at a time until the brake is released.

⚠ WARNING

The manual release bolts must be loosened to restore function of the secondary brake. Brake can be released for testing and maintenance only and must be reengaged prior to the hoist being returned to service.

2. Use a wrench to alternately and evenly loosen the two bolts until the brake is reengaged.

Controls Enclosure

⚠ DANGER

Electrocution hazard. Make sure power is off before opening controls enclosure.

1. Check that the power and controls plugs are latched into their receptacles.
2. Check for any missing fasteners in the enclosure.
3. Check to make sure that the strain relief clamps hold the power and control cables tightly in the plugs.

Inspection and Maintenance Procedures (continued)

Circuit Protection and Controls Electronics

⚠ DANGER

***Electrocution hazard.
Remove power source before
opening electrical enclosures.***

Fixed Speed Machines

Fixed speed machines are controlled through the use of a self-protected motor starter inside the controls enclosure. See Figure 9.

This unit includes both overload sensors and a disconnect switch to shut off the motor power.

The disconnect handle is turned to the "twelve o'clock" position to turn the power on, and to "nine o'clock" to turn the power off. This handle also functions as a fault indicator; when the sensors detect an overload, the power will automatically be disconnected, and the handle will snap to the "ten-thirty" position.

To reset a fault, turn the disconnect handle to the "reset" position (seven o'clock) and then back to the "on" position.

The dial of the overload sensor is set at the factory to match the motor's Full Load Amperage (FLA). Do not adjust this setting unless directed by a JR Clancy factory representative.

For all other adjustments to the control electronics contact the JR Clancy factory.

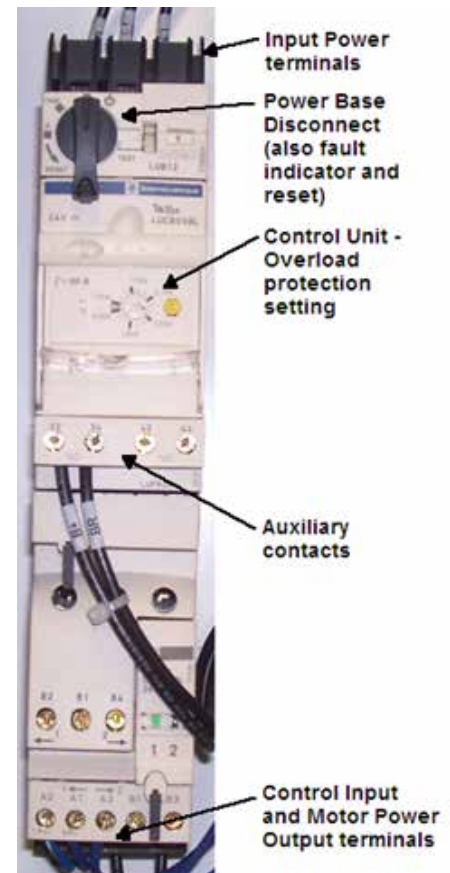

Figure 9: Fixed Speed Starter Module

Variable Speed Machines

1. Variable speed machines are controlled by an electronic drive module as well as being protected by a circuit breaker.

In the event of an overload or over-current situation the sensors built into the drive module will trigger a drive fault that will shut down the drive. A fault condition will be reported to the user at the motion control system console. The Fault Reset button on the main screen of the controller will reset the drive electronics.

2. The circuit breaker for the drive module is located either inside the drive enclosure or mounted into the electrical raceway adjacent to the power plug, depending on your installation. The circuit breaker can be manually switched to the ON or OFF positions.

In the event of a fault condition the breaker may switch to a TRIPPED position midway between ON and OFF. To reset the circuit breaker, move the switch to the OFF position and then back to the ON position.

For all other adjustments to the control electronics contact the JR Clancy factory.

Inspection and Maintenance Procedures (continued)

Limit Switch Settings

⚠ WARNING

Machinery and loads can collide with surroundings if limit switches are incorrectly adjusted.

Operate machine at slow speed only when setting limits.

Operator or observer must be in sight of all obstacles in the path of machine or load.

Do not operate over the heads of people.

⚠ WARNING

Wire Rope must have at least three complete wraps around the drum to avoid failure of the termination.

Check the Soft Limits

The Titan has upper and lower limits that are set from within the control system software ("soft" limits). These limit the travel of the hoist to prevent damage to the machine and the surrounding structure, and to prevent the load from hitting an obstruction and causing an unsafe condition.

1. Position the operator or an observer so that both ends of the drum can be seen.
2. Position the operator or an observer so that all parts of the lifted load can be seen.
3. Slowly run the hoist down until it reaches its soft lower limit, or approaches an obstruction. Confirm that the soft limit stops the hoist before the hoist reaches its hard-lower limit (see below). If the soft limit requires adjustment, see the control system Operations and Maintenance Manual.
4. Slowly run the hoist up until it reaches its soft upper limit, or approaches an obstruction. Confirm that the soft limit stops the hoist before the hoist reaches its hard-upper limit (see below). If the soft limit requires adjustment, see the control system Operations and Maintenance Manual.

Check the Hard Limits

The Titan features a four-element rotary limit switch to limit the travel of the hoist.

This switch includes four independently adjustable switches, two to limit the normal travel of the hoist in the up and down direction and two redundant overtravel switches which should be set just outside the normal travel limits.

In order to leave enough room for an emergency stop of the lifted load at full speed, the switches must be set so that striking the overtravel limit will stop the load with sufficient clearance from any obstruction. (See step 3 for clearance measurements.)

Inspection and Maintenance Procedures (continued)

Limit Switch Settings (continued)

Notice: The hoist should never strike the hard limit switches during normal operation.

The limits set in the control system ("soft" limits) should always activate first.

To check the hard limits, a Maintenance Control Pendant should be used.

The limit switch indicator lights on the Maintenance Control Pendant should be used to facilitate setting the limit switches.

Please contact JR Clancy to obtain a control pendant in order to check the hard limits. See the Titan Installation Manual for more information.

Limit switches must be set in the same way regardless of whether the hoist is controlled by a computerized control system or by push buttons.

- Run the machine to its lower overtravel ("hard") limit.
For all Titan units, confirm that the machine stops the load at least 6 inches (15 cm) from any obstruction.

⚠ WARNING

Load can hit surrounding structure and fall if clearance to obstruction is not maintained.

If adjustment of the limit switches is required use the following procedure:

1. Position the operator or an observer so that the limit switches and both ends of the drum can be seen.
2. Position the operator or an observer so that all parts of the lifted load can be seen.
3. Remove the limit switch cover.
4. Establish switch rotation:
 - a. Drive hoist in UP direction. Note the direction of the cam stack rotation.
 - b. Mark switch cover or label inside switch to record cam stack rotation.
 - c. Avoid contacting screw terminals on switches while control system is on.

Notice: Do not allow hoist drum to hit the machine frame.

Observe during operation prior to setting limit switches.

⚠ WARNING

Load can hit surrounding structure and fall if clearance to obstruction is not maintained.

5. Determine hoist travel:
 - a. Determine where load must stop to avoid damage to hoist, lifted load or surrounding structure. Set overtravel to stop load short of this point.
 - b. For each end of travel, set overtravel switch first, the normal end of travel switch.
 - c. At the lower end of travel, confirm there are at least three (3) standing "dead" wraps on the drum at all times.

Inspection and Maintenance Procedures (continued)

Limit Switch Settings (continued)

6. Adjust Limit:
 - a. Drive the hoist to the desired end of travel.
 - b. Re-verify cam stack rotation (when the hoist travels up, does the cam stack rotate clockwise or counterclockwise). Determine which side of the desired switch the limit cam must strike (i.e. if the cam stack rotates clockwise when the hoist travels down, and you are setting a down limit, the cam must actuate the down limit while moving in a clockwise direction).
 - c. Locate the adjusting screw for the desired limit by referring to the numbers adjacent to the adjusting screws. Note that the lowest switch in the cam stack (down overtravel) is switch 1, the next switch (down limit) is switch 2, the next switch (up limit) is switch 3, and the highest switch in the stack (up overtravel) is switch 4.
 - d. Rotate the adjusting screw with a 4mm allen wrench to adjust the limit cam lobe to a position where the selected limit switch is just actuated (audible click).

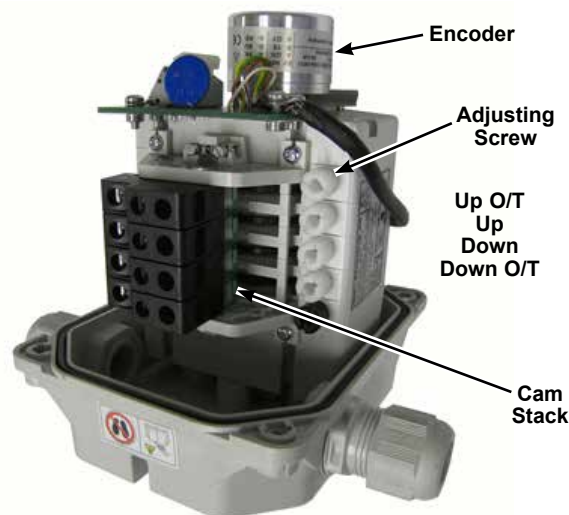

Figure 10: Stromag Rotary Limit Switch (with cover removed)

7. Test Limit
 - a. Drive hoist away from limit until limit is cleared (use overtravel bypass switch to move hoist off overtravel limit if needed).
 - b. Drive hoist toward limit until limit stops motion.
 - c. Assess stopping position (measurement vs. target).
 - d. Drive hoist off limit (use overtravel bypass switch to move hoist off overtravel limit if needed).
8. Refine Limit Adjustment
 - a. Repeat the Adjust Limit procedure, as detailed above.
 - b. Move cam lobe closer to switch to make switch trip sooner (decrease travel distance).
 - c. Move cam lobe further from switch to make switch trip later (increase travel distance).
 - d. Retest limit adjustment until hoist stops at desired position.

Inspection and Maintenance Procedures (continued)

Limit Switch Settings (continued)

9. Adjust Remaining Limits
 - a. Once overtravel limit is set, set normal limit at same end of travel.
 - b. Check to ensure that there is sufficient distance between normal limit and overtravel limit - if the hoist strikes both limits before stopping, increase the distance between the limits by moving the normal limit to stop the load sooner.
 - c. Once all limits are set, replace the limit switch cover.

Warning Signs and Operational Instructions

In the event that operation, service, or training questions arise, the users must have contact information for qualified service personnel readily available.

1. Make sure that the JR Clancy "Motorized Rigging" safety sign (Part # 002-WINSIGN) is placed in a prominent location and that the service contact information is filled in.
2. Make sure that the capacity labels are in place on each batten, and that the labels match the capacity of the machines to which they are attached.
3. Interview the user and make sure that they have access to the "Operation and Maintenance Manual." Also, a service log form is provided at the end of this manual. Locate this log and examine it. The following information should be recorded for each occasion of service:
 - Date of service
 - The provider of the service, with contact information.
 - The machinery, i.e. channel number, on which the service was performed.
 - The work or inspection that was performed.

Notice: Documentation of annual inspection is required to maintain the full warranty period of the hoist and may need to be provided upon request to obtain warranty service.

Decommissioning and Disposal

Lubricants and other components that can be procured locally are fully specified in the appropriate section of this manual. Use only the specified type and grade of materials.

Contact your local JR Clancy dealer to obtain any parts not listed in this document.

Remove machines if necessary using qualified personnel and safe rigging practices.

Any modifications to the structure and wiring must be performed by qualified persons and conform to local codes.

Do not defeat interlock switches or any other safety features of remaining machines or control system.

Dispose of all materials according to local codes.

