

# Vantis™ Pendant Controller

The Vantis Pendant Controller offers simple control of up to eight machines. Each machine can be programmed with up to six targets including upper, lower and four intermediate targets. Selection of multiple hoists or other machine types is easy as well as the ability to move them to a target together. Variable speed control lets you use this controller on drapery or scenery sets during production.

## Applications

Venues with up to eight motorized machines that need the simplicity and mobility of a pendant controller and the ability to easily access and record targets.

## Key Features

- Up to eight (8) machines
- Variable speed control
  - variable when operating a single machine
  - default speed when operating multiple machines
- Up to six (6) targets per machine – four (4) user recordable
- Operation of various set types including hoists, acoustic banners and travelers
- Load sensing

## Specifications

- Illuminated GO button
- 3.5" (89 mm) color touchscreen
- Control wheel for variable speed control

## Safety

- Emergency Stop Operator
- Hold-to-Run operation
- Multi-Level security
- Status/Alarm indication

## Dimensions

14" h x 4" w x 3-3/8" d  
(356 x 102 x 86 mm)

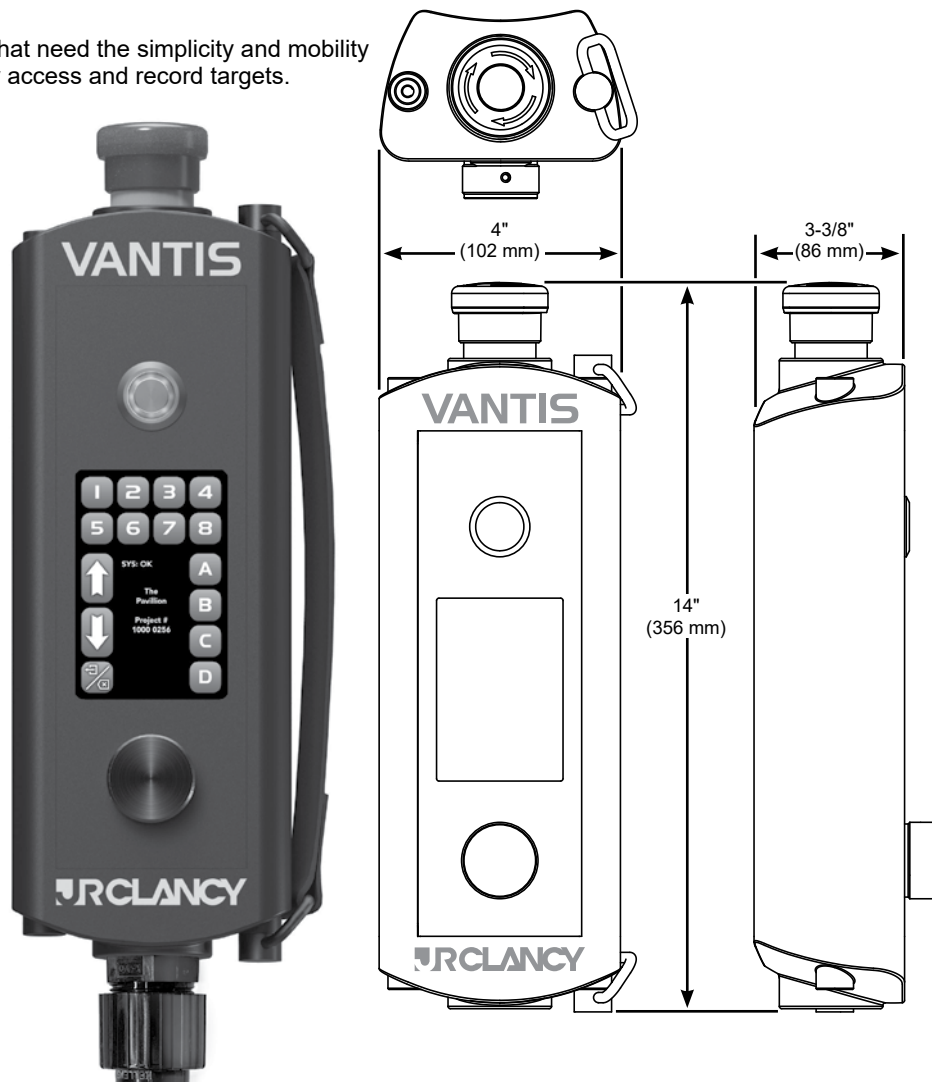

## Warranty and Support

Three-Year Warranty against defects in materials or workmanship is provided on all J.R. Clancy equipment. Our warranty is contingent on operation by trained personnel and an annual equipment inspection by a Wenger Corporation-authorized technician.

24/7 factory technical service and support.

Inspection and maintenance are available through our J.R. Clancy T.I.M.® (Train, Inspect, Maintain) Program. For more information call 800-836-1885 or email [service@wengercorp.com](mailto:service@wengercorp.com).

## Additional Information

Additional information on J.R. Clancy systems is available at [jrclancy.com](http://jrclancy.com) or [performance.wengercorp.com](http://performance.wengercorp.com).

## Order Information

060-VANTIS-PENDANT



© 2020 Wenger Corporation  
USA/2020-07

## MUSIC EDUCATION AND PERFORMING ARTS

Owatonna Office: Phone 800.4WENGER (493-6437) Worldwide +1.507.455.4100 | Parts & Service 800.887.7145 | [wengercorp.com](http://wengercorp.com)  
555 Park Drive, PO Box 448 | Owatonna | MN 55060-0448

Syracuse Office: Phone 800.836.1885 Worldwide +1.315.451.3440 | [jrclancy.com](http://jrclancy.com) | 7041 Interstate Island Road | Syracuse | NY 13209-9713

**ATHLETICS** Phone 800.493.6437 | email [gearboss@wengercorp.com](mailto:gearboss@wengercorp.com) | [gearboss.com](http://gearboss.com) | 555 Park Drive, PO Box 448 | Owatonna | MN 55060-0448