

GearBoss® Shelving

GearBoss Shelving is designed for needs all over the facility from athletics to fine arts to general storage areas. The unique design provides cantilevered shelves keeping areas underneath free from supports and available for carts and mobile storage.

The system is easily installed and shelves and accessories can be adjusted quickly without tools.

GearBoss Shelving comes in standard bays that are 4' wide and 8' high (1219 x 2438 mm) and can be mounted on block wall and wood or metal stud walls.

Intended Use

- The GearBoss Shelving System is intended to maximize storage density in areas where there is storage need and space limitations.
- The GearBoss Shelving System is intended for indoor use in normal ambient temperature and humidity conditions - components must not be exposed to prolonged outside weather conditions.

Specifications

- Galvanized 2" square 12-gauge steel uprights with galvanized 14-gauge shelf support bracket and 14-gauge tube support brackets.
- Durable silver powder-coat paint finish.
- Each bay section measures approximately 4' wide x 8' high (1219 x 2438 mm).
- Each 4' (1219 mm) wide bay is rated for 1000 lbs (454 kg) evenly distributed.
- UL GREENGUARD Certified - Product certified for low chemical emissions: ul.com/gg - UL 2818.
- Environmental attributes and LEED compliance for this product can be found at www.wengercorp.com/GREEN or by contacting your Wenger representative.
- Shipped ready-to-assemble with detailed instructions. Wenger assembly and installation is optional.
- Product Numbers: 241C025 - GearBoss Shelf Starter Bay, 241C026 - GearBoss Shelf Add-On Bay.
- Patent and Patents Pending.
- Ten-year warranty.

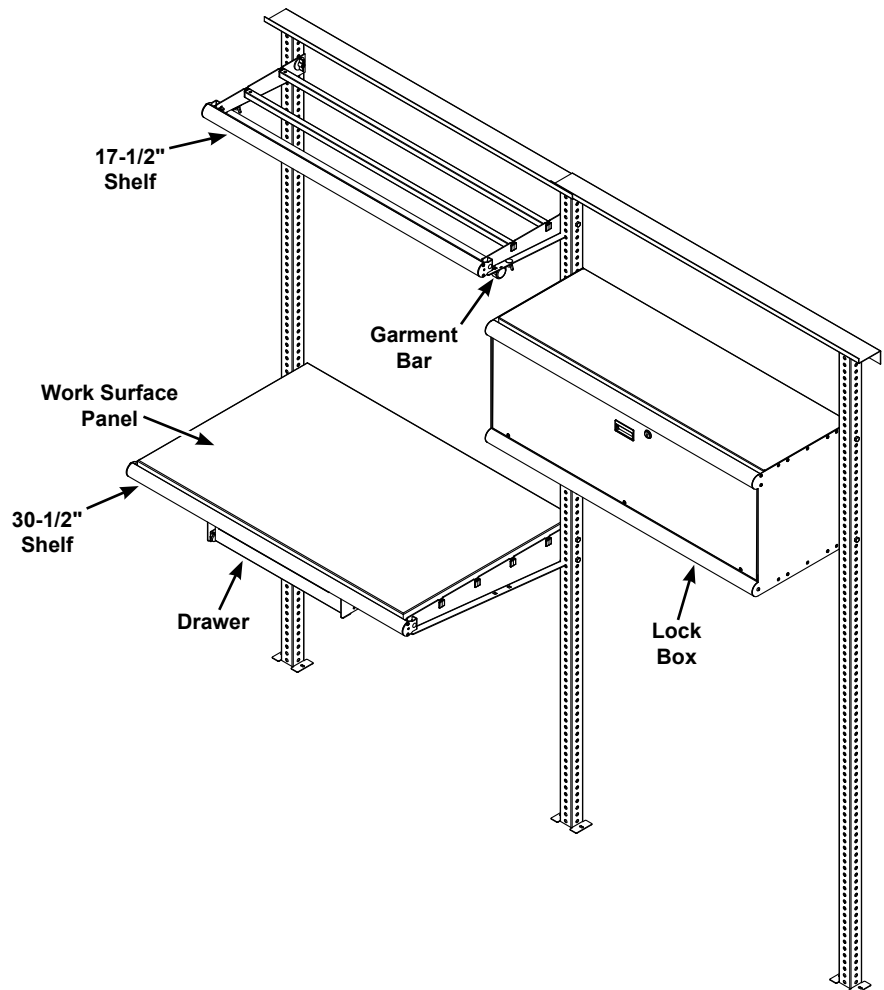

Accessories continued on next page.

Accessories

Shelves, 30-1/2" and 17-1/2"

- 30-1/2" (775 mm) cantilevered shelf with 4 support tubes spaced 5-1/4" (133 mm).
- 17-1/2" (445 mm) cantilevered shelf with 2 support tubes spaced 5-1/4" (133 mm).
- Shelves can be mounted and adjusted in 1" (25 mm) increments without tools.
- Both shelves fronted with a contoured aluminum extrusion with a 3/8" (9 mm) lip to retain a hardboard insert if necessary.
- Each shelf is rated for 250 lbs (113 kg) evenly distributed, not to exceed 1,000 lbs (454 kg) per bay.
- All steel parts have a durable silver powder-coat paint finish.
- Shelf brackets are formed 12-gauge steel.
- Shelf support are 14-gauge 7/8" (22 mm) steel tubes.
- Product Number: 241C001 for 30-1/2" (775 mm) shelf and 17-1/2" (445 mm) shelf.

Work Surface Panel

- 29-1/4" (743 mm) x 44-3/4" (1137 mm) panel lays directly inside a 30-1/2" shelf.
- 1-1/8" (29 mm) graphite polyester laminated particle board with PVC edgebanding - black only.
- Product Number: 241B030.

Drawer

- Mounts to underside of a work surface panel accessory for a 30-1/2" shelf.
- 14-gauge steel construction.
- Durable black powder-coat paint finish.
- Rated for 100 lbs (45 kg) evenly distributed.
- Product Number: 241A049.

Garment Bar/Hanging Bar

- 48" (1219 mm) x 14-gauge x 1-1/2" (38 mm) round steel tube.
- All steel parts have a durable black powder-coat paint finish.
- Durable black powder-coat paint finish.
- Mounts to underside of shelves without tools.
- Rated for 100 lbs (45 kg) evenly distributed.
- Product Number: 241C004.
- Interchangeable companion products: 240B056.1 - Football helmet hanger, 1510902 - Shoulder pad hanger - long, 1510901 - Shoulder pad hanger - short.

Lock Box

- Door is hinged at the bottom so it may drop and stay open for easy access.
- Sides, top and bottom panels are 16-gauge steel.
- Features upper and lower contoured aluminum extrusions, a key tab-lock and laminated wood door.
- Door is 5/8" (16 mm) graphite pebble polyester laminated board with PVC edgebanding - black only.
- Rated for 100 lbs (45 kg) evenly distributed.
- Mounted and adjustable without tools.
- Dimensions: 16" x 18" x 46" (406 x 457 x 1168 mm).
- Product Number: 241A007.

Peg Board Back

- Mounts directly onto existing shelf banks.
- Rated for 40 lbs (18 kg) evenly distributed.
- Product Number: 241A079.
- The 1/4" thick peg board material is not supplied by Wenger and must be purchased separately.

Wenger

JRCLANCY

GEARBOSS

© 2018 Wenger Corporation
USA/2018-09/W



WENGER CORPORATION Phone 800.4WENGER (493-6437) Worldwide +1.507.455.4100 | Parts & Service 800.887.7145 | Canada Office 800.268.0148 | wengercorp.com
555 Park Drive, PO Box 448 | Owatonna MN 55060-0448

JR CLANCY Phone 800.836.1885 Worldwide +1.315.451.3440 | jrclancy.com | 7041 Interstate Island Road | Syracuse NY 13209-9713

GEARBOSS Phone 800.493.6437 | email gearboss@wengercorp.com | gearboss.com | 555 Park Drive, PO Box 448 | Owatonna MN 55060-0448