

GearBoss® Sports Storage System

GearBoss is an athletic equipment storage and transportation solution designed to transform your equipment room into a point of pride. GearBoss is a high-density storage solution that uses an innovative system of rolling carts and accessories to reduce the square footage of your storage area. GearBoss units are designed to encourage airflow and improve sanitation and odor issues. Accessories like closure panels and doors can be added for security, and in matching school colors, they present an unmistakable message of program pride. All SportCarts have a five-year warranty.

Intended Use

- The GearBoss SportCart is intended for use as a mobile storage unit that can also transport equipment closer to points of use such as a gymnasium and can be secured to create storage around your facility.
- The GearBoss SportCart is intended for indoor use in normal ambient temperature and humidity conditions - components must not be exposed to prolonged outside weather conditions.
- The heavy-duty commercial-grade swivel casters are intended for easy moving on hard surfaces.

Specifications

- Welded chassis made from 14-gauge and 12-gauge components.
- Upright support tubes constructed from large 2" (51 mm) diameter, 16-gauge steel tubing.
- Resistant welded heavy-duty steel wire grill end frames.
- Durable powder paint coat finishes.
- Various colors available for wire grill ends.
- Heavy-duty 5" swivel casters with Polyolefin non-marring wheels.
- Roof panel constructed from solid 5/8" thermofused composite wood core with aluminum extrusions, the roof assembly is rated for a 150 lbs (68 kg) load.
- SportCart Dimensions: 32" wide x 41.8" long x 74" high (813 x 1062 x 1880 mm).
- Approximate Weight: 150 lbs. (68 kg).
- UL GREENGUARD Certified - Product certified for low chemical emissions: ul.com/gg - UL 2818.
- Environmental attributes and LEED compliance for this product can be found at www.wengercorp.com/GREEN or by contacting your Wenger representative.
- Product Number: 240A809.3.
- Patent and Patents Pending.
- Shipped ready-to-assemble with detailed instructions. Wenger assembly and installation is optional.

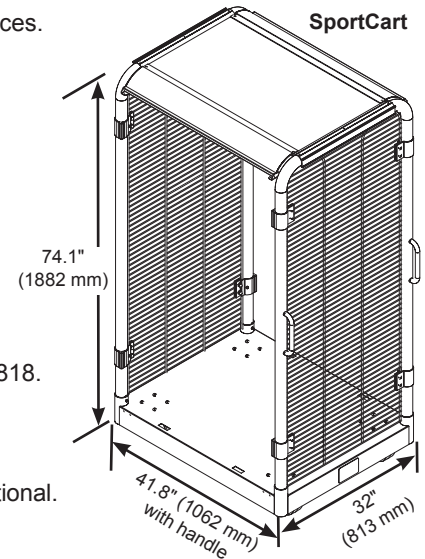

Accessories

Swing Door & Side Closure Accessory

- Lockable door for added security.
- Can be ordered in a variety laminate colors.
- Made from solid 5/8" thermofused composite wood core with black polyester edge banding.
- Shipped ready-to-assemble.
- Dimensions: Swing Door 34-1/8" x 63-1/2" (867 x 1613 mm).
Side Closure 34-7/8" x 65-5/8" (886 x 1667 mm).
- Approximate Weight: Swing Door 52 lbs. (24 kg).
Side Closure 41 lbs. (19 kg).
- Product Number: 240A189.

Swing Door & Side Closure Accessory

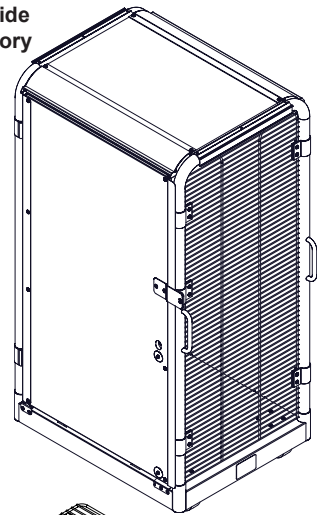

Garment Bar

- Designed to be installed using two accessory hanger brackets.
- Designed to be used with standard garment hangers and supports up to 80 jerseys.
- Durable black powder-coat paint finish.
- Shipped ready to be installed, no tools required.
- Dimensions: 37-1/2" (953 mm) x 1-1/2" OD.
- Rated for 100 lbs. (45 kg) evenly distributed.
- Product Number: 240A079.

Garment Bar Accessory



Metal Wire Shelves

- Designed to be installed using four accessory hanger brackets per shelf.
- Resistant welded construction of 3/16" and 5/16" (0.1875" and 0.3125") metal wires.
- Shipped ready to be installed, no tools required.
- Rated for 150 lbs. (68 kg) evenly distributed.
- Dimensions: 27-5/8" x 37" (702 x 940 mm).
- Approximate Weight: 20 lbs. (9 kg).
- Product Number: 240A140.

Wire Shelf Accessory

