

GearBoss® Sports Storage System

GearBoss is an equipment storage and transportation solution designed to transform your equipment room into a point of pride. GearBoss is a high-density storage solution that uses an innovative system of tracks and rolling carts and accessories to reduce the square footage of your storage area by at least half. GearBoss units are designed to encourage airflow and improve sanitation and odor issues. The modular system features accessories specific for the needs of bulky equipment like helmets and shoulder pads. Accessories like panels and doors can be added for security, and in matching school colors they present an unmistakable message of program pride. All X-Carts have a five-year warranty.

Intended Use

- The GearBoss X-Cart, is intended for permanent use on the track converting a traditional storage area into an organized, secure high-density space.
- The GearBoss X-Cart is intended for indoor use in normal ambient temperature and humidity conditions - components must not be exposed to prolong outside weather conditions.

System Description

- GearBoss X-Carts are available in 32" and 48" (813 and 1219 mm) widths.
- Aluminum Rail extrusion holds carts in place and guides them as they are moved.
- 8' (2438 mm) sections affix to floor with anchor bolts.
- Roller guides follow the track keeping the units aligned and are made of glass-filled nylon.
- Welded chassis made from 16-gauge, 14-gauge and 12-gauge components.
- Upright support tubes constructed from large 2" (51 mm) diameter, 16-gauge steel tubing.
- Resistant welded heavy-duty steel wire grill end frames.
- Durable powder-coat paint finishes.
- Various colors available for wire grill ends.
- Heavy-duty 8" (203 mm) wheels provide easy movement.
- Roof panel constructed from solid 5/8" thermofused composite wood core with aluminum extrusions, the roof assembly is rated for 150 lbs. (68 kg) load.
- 32" X-Cart dimensions, 32" wide x 78" long x 79" high (813 x 1981 x 2007 mm)
- 48" X-Cart dimensions, 48" wide x 78" long x 79" high (1219 x 1981 x 2007 mm).
- Approximate Weight: 32" (813 mm) X-Cart, 250 lbs. (113.4 kg)
- 48" (1219 mm) X-Cart, 335 lbs. (151.9 kg).
- UL GREENGUARD Certified - Product certified for low chemical emissions: ul.com/gg - UL 2818.
- Environmental attributes and LEED compliance for this product can be found at www.wengercorp.com/GREEN or by contacting your Wenger representative.
- Shipped ready-to-assemble with detailed instructions. Assembly takes approximately 60 min with two people per cart. Wenger assembly and installation is optional.
- Product Numbers: 32" (813 mm) X-Cart 240A801
- 48" (1219 mm) X-Cart 240A800.
- Patent Pending.

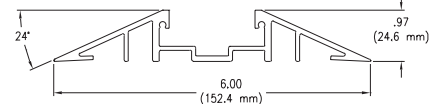
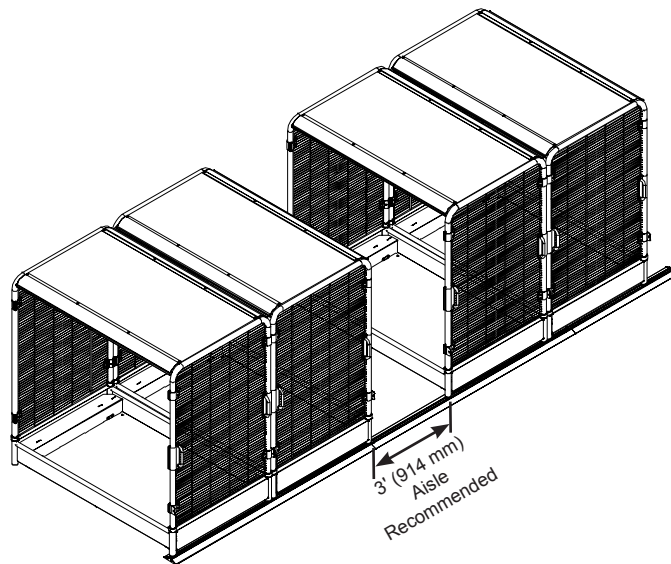
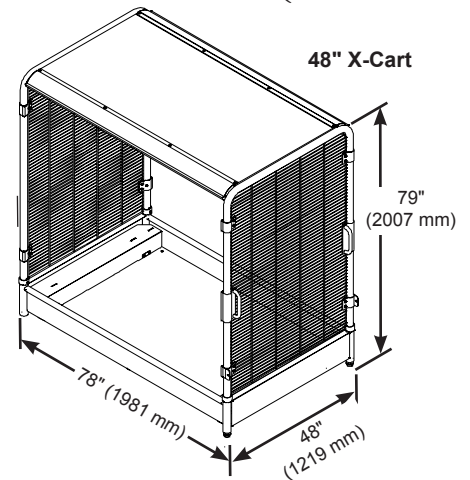
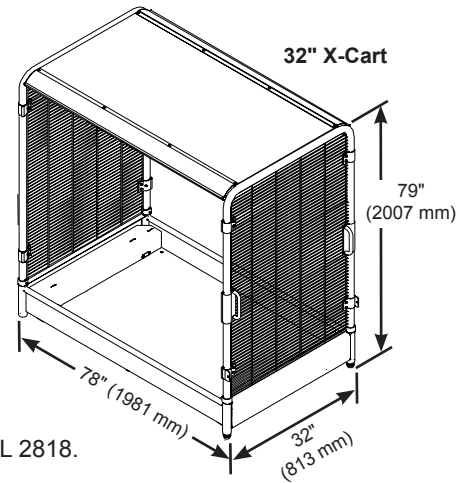

Aluminum Rail Extrusion