

Guitar Storage Rack

- 148J006_ , Guitar Storage Rack, 147 lbs (67 kg).
- Designed to transport and store up to 20 acoustic or electric guitars.
- Stores up to 10 mariachi guitars and guitarrons.
- Can store cased and uncased guitars.
- Adjustable height upper cross supports to fit 3/4 to full size guitars.
- Adjustable yokes to accommodate various styles and are removable to accommodate cased guitar storage.
- Optional security cables help prevent instrument theft using standard padlocks with 3/8" (10 mm) maximum diameter x 1-3/8" (35 mm) wide shackle. (padlocks not included)
- Four swivel, hard rubber casters, with two front locking, 4" (102 mm) in diameter.
- Fits through 33" (838 mm) wide door opening.
- End panels are 3/4" (19 mm) thick industrial grade composite wood with no added formaldehyde and polyester laminate finish in Wenger standard colors.
- Edging is 1/8" (3 mm) radiused PVC.
- Lower cross supports are plywood core laminated panels with flexible soft PVC edging to protect instruments.
- Dimensions: 65-3/4" long x 29-1/2" deep x 72" high (1670 x 750 x 1829 mm).
- UL GREENGUARD Certified - Product certified for low chemical emissions: ul.com/gg - UL 2818.
- Environmental attributes and LEED compliance for this product can be found at www.wengercorp.com/GREEN or by contacting your Wenger representative.
- Assembly required.
- Five-year warranty.

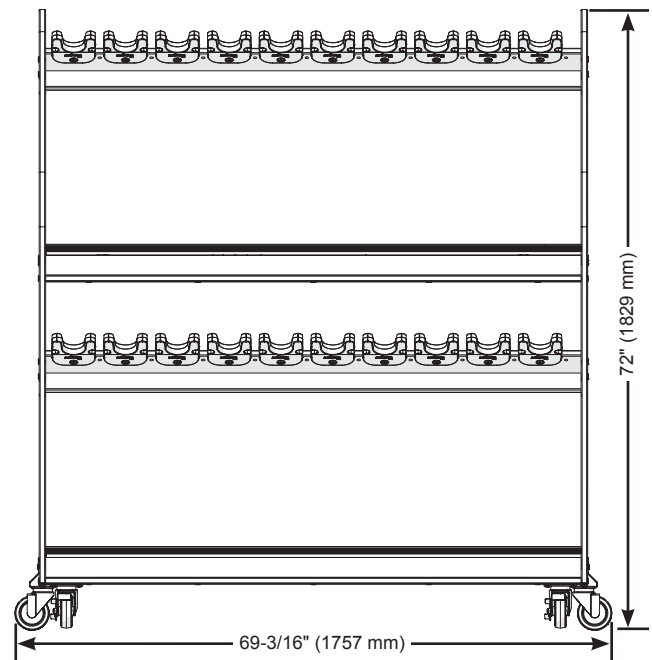

© 2017 Wenger Corporation
USA/2017-12/W

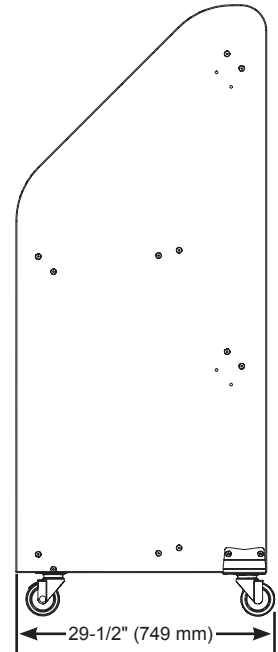
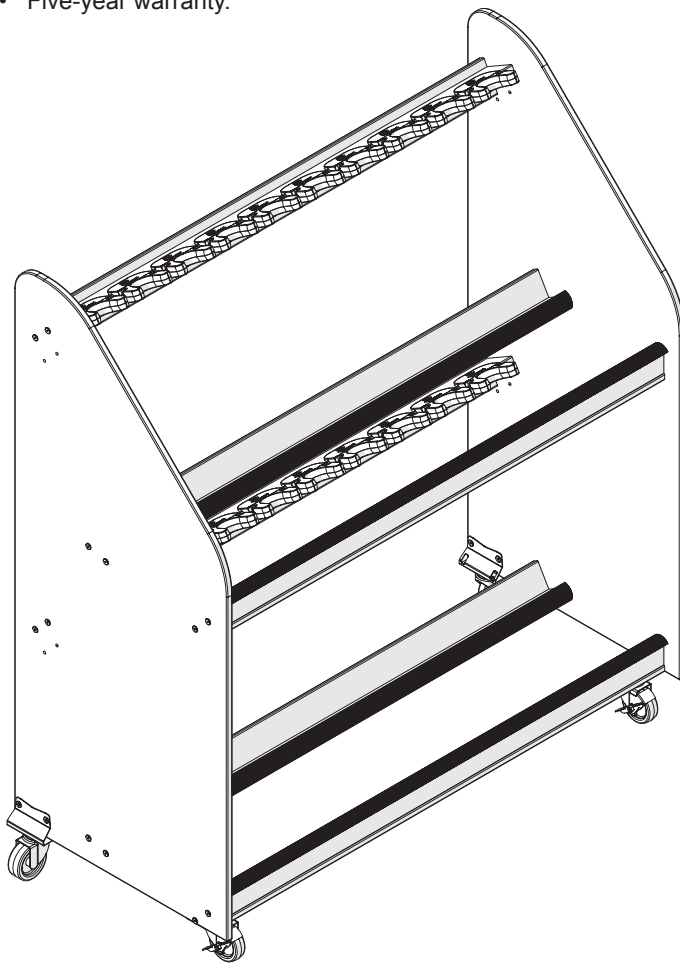

WENGER CORPORATION

Phone 800.4WENGER (493-6437) Worldwide +1.507.455.4100 | Fax 507.455.4258 Worldwide +1.507.774.8576
Parts & Service 800.887.7145 | Canada Office 800.268.0148 | Web wengercorp.com | 555 Park Drive, PO Box 448 | Owatonna | MN 55060-0448

JR CLANCY

Phone 800.836.1885 Worldwide +1.315.451.3440 | Fax 877.836.1885 Worldwide +1.315.451.1766 | Web jrclancy.com
7041 Interstate Island Road | Syracuse | NY 13209-9713

GEARBOSS

Phone 800.493.6437 | email gearboss@wengercorp.com | Web gearboss.com | 555 Park Drive, PO Box 448 | Owatonna | MN 55060-0448