

# OnBoard® Keyboard Cart

- 210C005 OnBoard Keyboard Cart, 150 lbs. (68 kg).
- Ideal for transporting electronic keyboard equipment onto the field for marching band competitions.
- Designed to fit into trailers, semi-trailers and trucks.
- Fits through standard 32" (813 mm) door.
- Bottom shelf stores audio components, cables, and small speakers.
- Top shelf rotates (10 degrees maximum), and includes adjustable clamps for holding keyboard in place.
- Top shelf adjusts vertically in 1-1/2" (38 mm) increments, allowing 3" (76 mm) of total adjustment.
- 100' (30480 mm) capacity power cord reel included.
- Tow bar included for pulling additional carts or with small garden tractor or Gator™.
- Accommodates up to 88-key keyboards.
- Optional shelf extensions available for placement of small speakers or small mixer.
- Durable black powder-coat paint finish.
- Upright tubes constructed of 14-gauge 1-3/4" (45 mm) round tubing, with aluminum extrusion.
- Two swivel and two rigid 8" (203 mm) dia. pneumatic casters provide easy maneuverability on all surfaces.
- Top and bottom shelf constructed of 16-gauge steel with black powder-coat paint finish.
- Dimensions: 68-3/4" (1746 mm) long x 31" (787 mm) deep x 41" to 44" (1041 to 1118 mm) high.
- UL GREENGUARD Certified - Product certified for low chemical emissions: [ul.com/gg](http://ul.com/gg) - UL 2818.
- Environmental attributes and LEED compliance for this product can be found at [www.wengercorp.com/GREEN](http://www.wengercorp.com/GREEN) or by contacting your Wenger representative.
- Five-year warranty.
- Ships fully assembled.

## Accessories

- 210A008 - Shelf Extensions, 2-pack, 25 lbs (11kg)

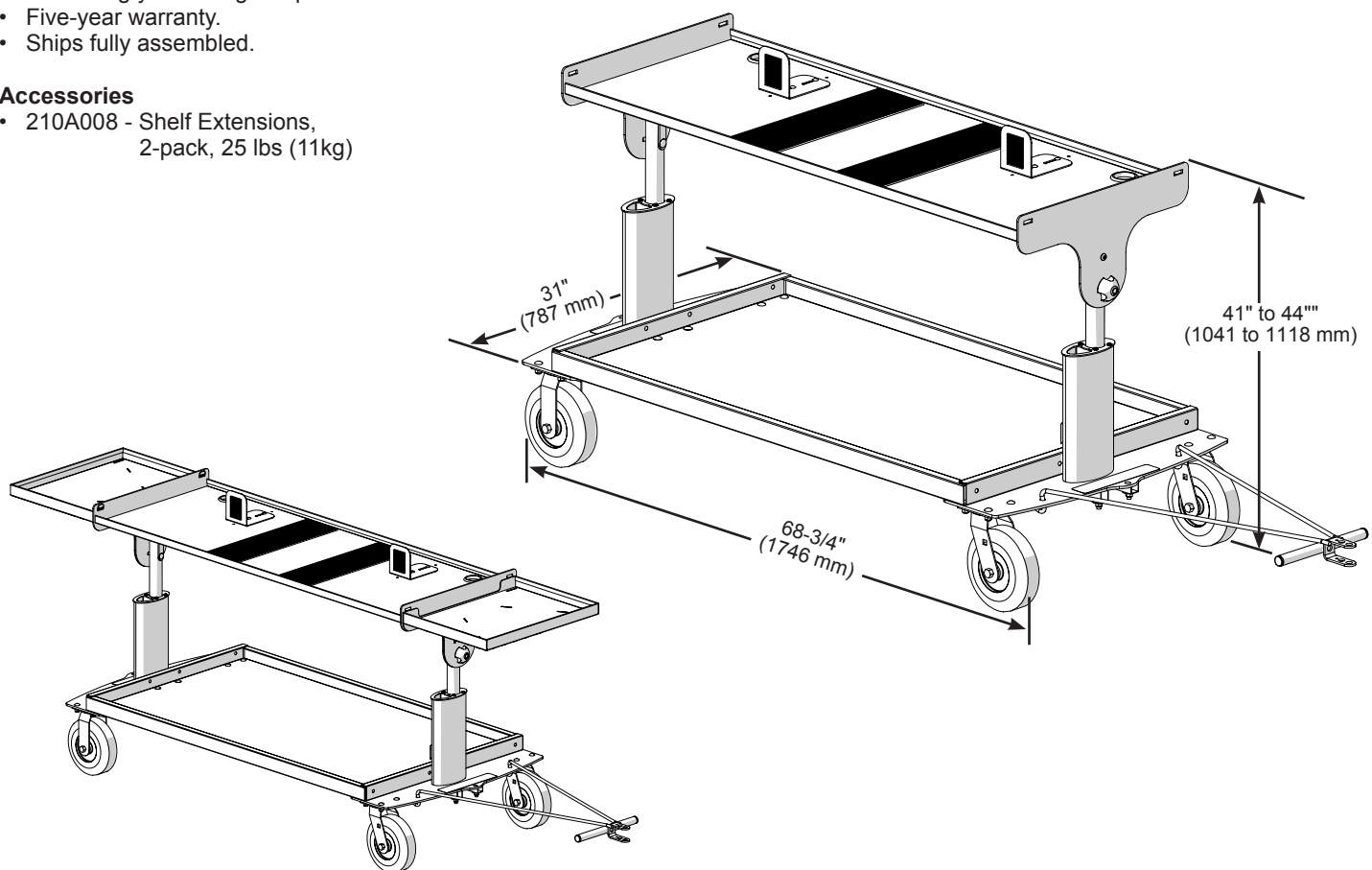

OnBoard Keyboard Cart shown with optional shelf extensions.



© 2017 Wenger Corporation  
USA/2017-12/W



## WENGER CORPORATION

Phone 800.4WENGER (493-6437) Worldwide +1.507.455.4100 | Fax 507.455.4258 Worldwide +1.507.774.8576  
Parts & Service 800.887.7145 | Canada Office 800.268.0148 | Web [wengercorp.com](http://wengercorp.com) | 555 Park Drive, PO Box 448 | Owatonna | MN 55060-0448

## JR CLANCY

Phone 800.836.1885 Worldwide +1.315.451.3440 | Fax 877.836.1885 Worldwide +1.315.451.1766 | Web [jrclancy.com](http://jrclancy.com)  
7041 Interstate Island Road | Syracuse | NY 13209-9713

## GEARBOSS

Phone 800.493.6437 | email [gearboss@wengercorp.com](mailto:gearboss@wengercorp.com) | Web [gearboss.com](http://gearboss.com) | 555 Park Drive, PO Box 448 | Owatonna | MN 55060-0448