

# OnBoard® Percussion Cart

- 210C006 OnBoard Percussion Cart, 90 lbs. (41 kg).
- Ideal for transporting small percussion equipment onto the field for marching band competitions.
- Designed to fit into trailers, semi-trailers and trucks.
- Fits through standard 32" (813 mm) door.
- Ergonomic curved design with all instruments within arm's reach for easy playing ability.
- Tow bar included for pulling additional carts or with small garden tractor or Gator™.
- Includes four accessory mounts for attaching small percussion instruments. Additional accessory mounts are available.
- Durable black powder-coat paint finish.
- Top curved bar constructed of durable 0.125" (3 mm) thick wall x 2" (51 mm) square aluminum extrusion.
- Bottom curved bar constructed of 14-gauge, 1" (25 mm) x 1-1/2" (38 mm) steel tubing.
- Upright tubes constructed of 14-gauge 1-3/4" (45 mm) round tubing.
- Attractive aluminum extrusion includes pocket for storage of mallets and drumsticks.
- Two swivel and two rigid 8" (203 mm) diameter pneumatic casters provide easy maneuverability on all surfaces.
- Dimensions: 72-1/4" (1835 mm) long x 31" (787 mm) deep x 49-1/2" (1257 mm) high.
- UL GREENGUARD Certified - Product certified for low chemical emissions: [ul.com/gg](http://ul.com/gg) - UL 2818.
- Environmental attributes and LEED compliance for this product can be found at [www.wengercorp.com/GREEN](http://www.wengercorp.com/GREEN) or by contacting your Wenger representative.
- Five-year warranty.
- Shipped fully assembled.

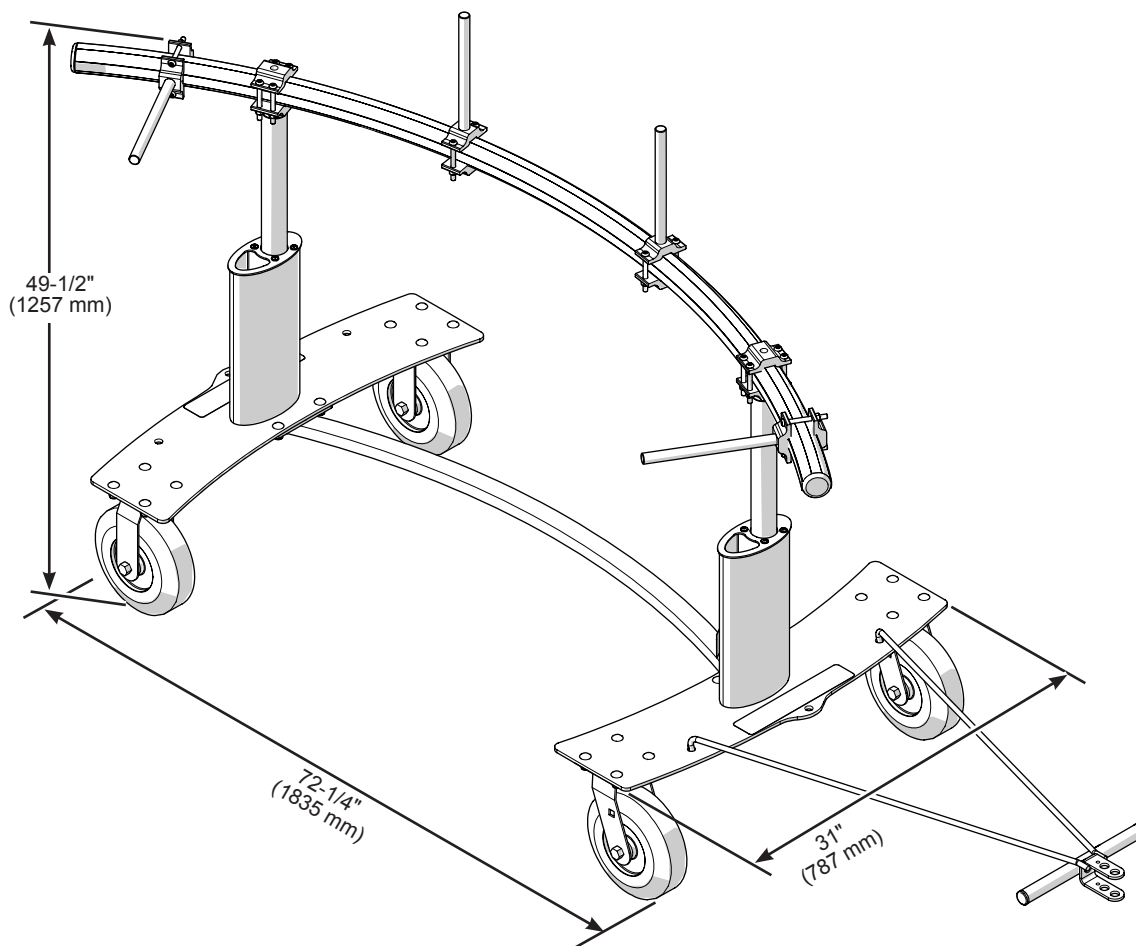

© 2017 Wenger Corporation  
USA/2017-12/W

