

# Trouper® Seated Choral Risers

- System consists of individual Trouper staging units, combined to create a multi-level seating arrangement.
- Platforms are available in 3' x 6' (914 x 1829 mm) and 3' x 8' (914 x 2438 mm) surface dimensions and in standard heights of 8" (203 mm), 16" (406 mm), 24" (610 mm), and 32" (813 mm). Pie-shaped units are also available.
- Decks are available in the following surfaces:  
 Black: 3/4" (19 mm) 7-ply plywood with a black slip resistant thermally fused overlay.  
 Grey Carpet: 3/4" (19 mm) 7-ply plywood with 1/8" (3 mm) (approximate pile height) manufacturer's standard grey carpet.
- Legs are one-piece, 16-gauge, 1-1/4" (32 mm) tubular steel.  
 Legs are designed to open in one motion and are automatically locked in place by a spring-loaded clip.
- Wrap around 16-gauge steel provides strength and protects the deck edge from damage.
- Frame clamps are a quick cam-type lock for positive locking to the frame of the adjacent unit.  
 One clamp per side of each stage unit, which provides two clamps per side when units are locked together.  
 Wood spacers securely hold the units of different heights together.
- Environmental attributes and LEED compliance for this product can be found at [www.wengercorp.com/GREEN](http://www.wengercorp.com/GREEN) or by contacting your Wenger representative.
- Five-year warranty.

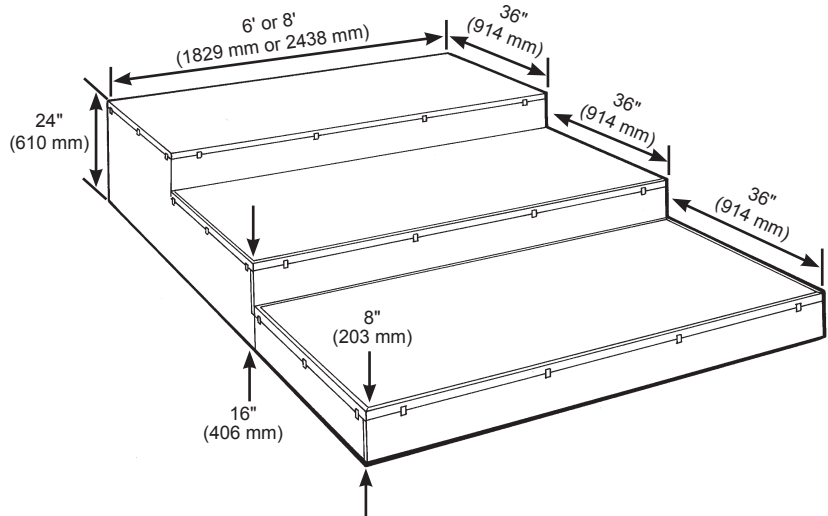
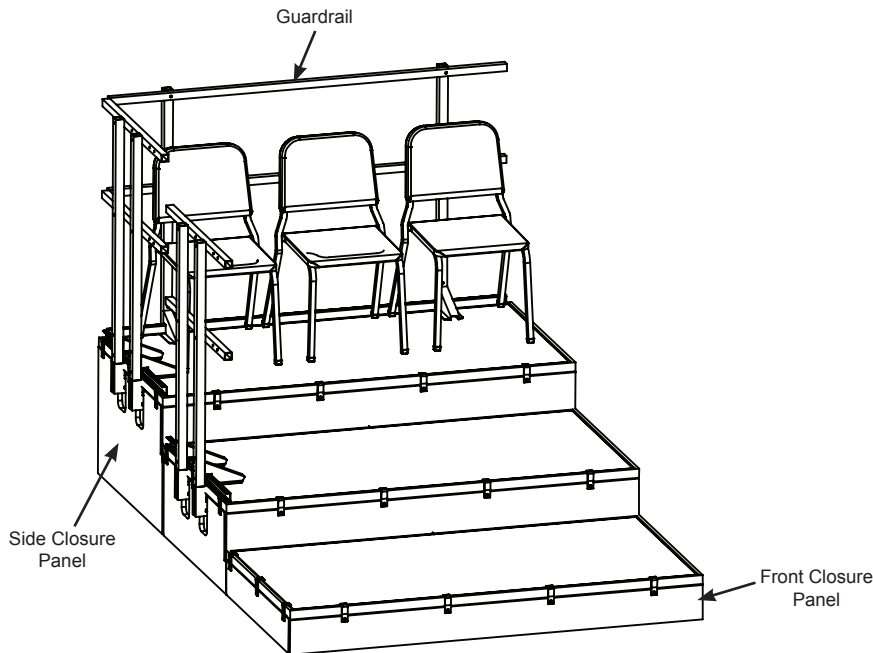

**Accessories**

- Side Closure Panels – Close each end of the riser arrangement.
- Front Closure Panels – Closes the gaps between elevations. Gives a finished-off, built-in look.
- Guardrails – Provide a measure of protection while adding a professional appearance.
- Transport Carts – Move units from one location to another. Enables efficient two-person handling.
- Guardrail Carts – Move guardrails from one location to another.

**Guardrail, Stairway, Backdrop and Drapery**

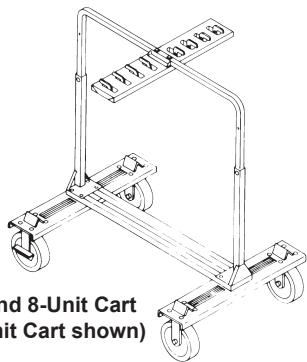
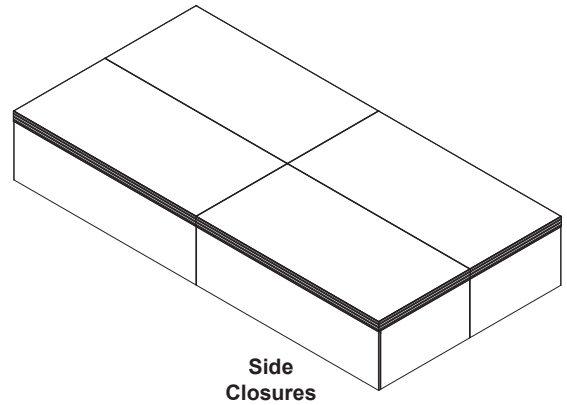
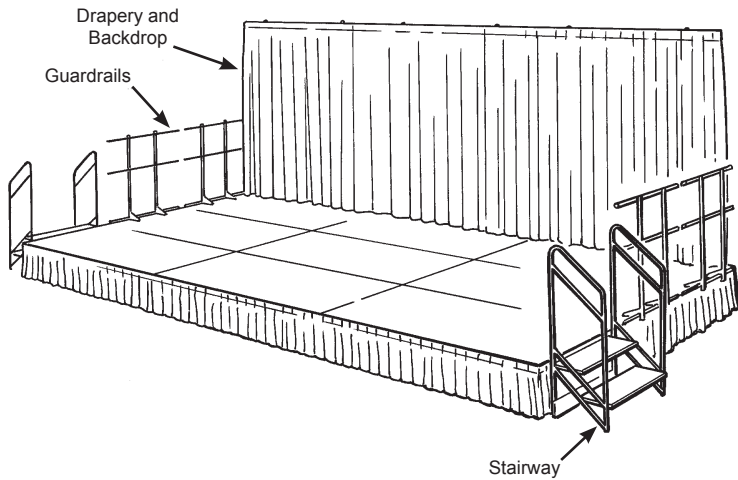

**Loaded 8-Unit Cart**

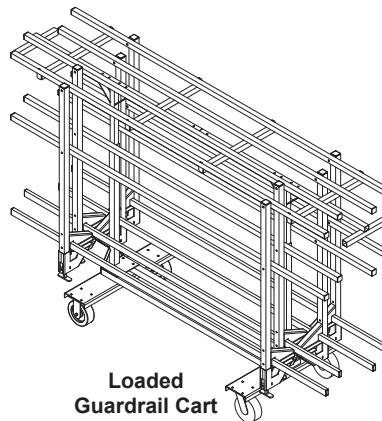
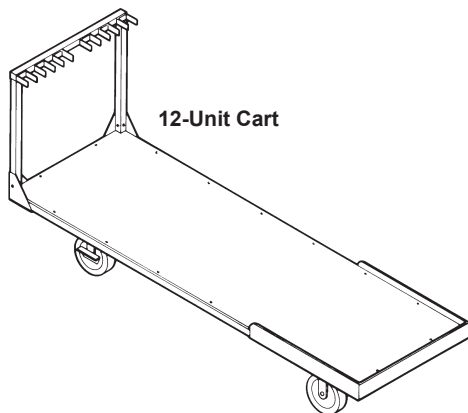
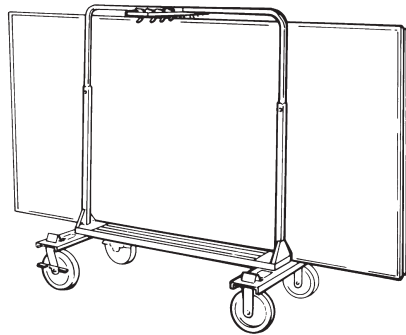

© 2017 Wenger Corporation  
USA/2017-12/W



**WENGER CORPORATION**

Phone 800.4WENGER (493-6437) Worldwide +1.507.455.4100 | Fax 507.455.4258 Worldwide +1.507.774.8576  
Parts & Service 800.887.7145 | Canada Office 800.268.0148 | Web wengercorp.com | 555 Park Drive, PO Box 448 | Owatonna | MN 55060-0448

**JR CLANCY**

Phone 800.836.1885 Worldwide +1.315.451.3440 | Fax 877.836.1885 Worldwide +1.315.451.1766 | Web jrclancy.com  
7041 Interstate Island Road | Syracuse | NY 13209-9713

**GEARBOSS**

Phone 800.493.6437 | email gearboss@wengercorp.com | Web gearboss.com | 555 Park Drive, PO Box 448 | Owatonna | MN 55060-0448