

# Bravo™ Music Stand

- 1020000 Standard Bravo Music Stand 7 lb (3.1 kg)
- Black polycarbonate desk with accessory shelf
- Base and tube are black powder-coat paint finish for maximum durability; Tube chrome finish is also available
- 20-3/8" x 13-1/2" (518 x 343 mm) desk with 19" x 2-1/2" (483 x 64 mm) accessory shelf
- 18-gauge upright post for added strength and stability
- Unique composite spring mechanism with premium holding ability adjusts height from 22-1/2" to 46-1/2" (572 to 1181 mm) (desk lip to floor)
- UL GREENGUARD certified - product certified for low chemical emissions: [ul.com/gg](http://ul.com/gg) - UL 2818
- Ten-year warranty

## Accessories

### Electric Music Stand Light

Classic stand light fits all Wenger stands, and most other manufacturers' stands

1090001 Music Stand Light, 14 oz (0.4 kg)

### LED Music Stand Lights

Compact, attractive, and adjustable, these battery-operated stand lights work with all Wenger stands

Features all-LED technology, so no bulbs to replace

237A040 HammerHead LED Music Stand Light, 2.1 oz (0.06 kg)

237A035 Encore LED Music Stand Light, 4.3 oz (0.12 kg)

237A033 Orchestra Music Stand Light, 10.2 oz (0.29 kg)

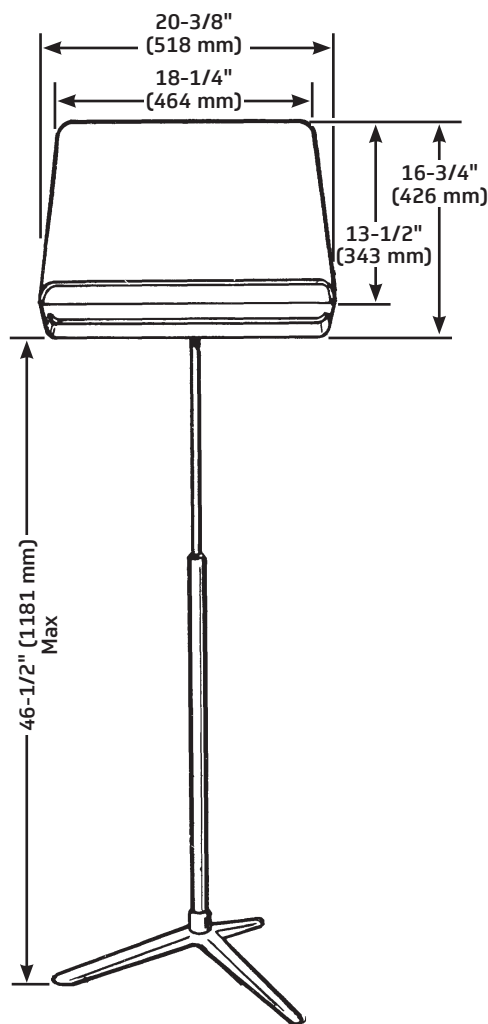
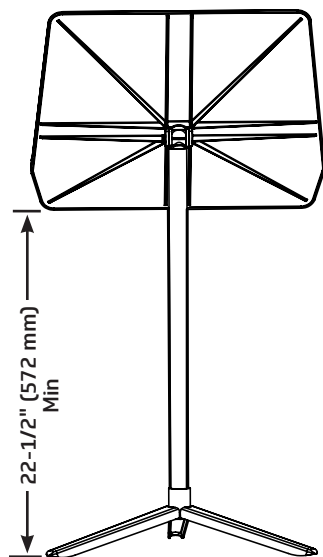
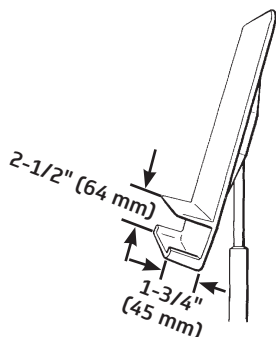

## Accessories (continued)

### Hands-Free Page Turner

A rugged hands-free device for turning the pages on your digital sheet music. Simple setup and operation make this a great solution for musicians who need a hand.

- Tap the foot switches to turn the pages on your digital sheet music forward or backward
- No messy cables, wireless connection to tablets or computers up to 60' (18 m) away using secure Bluetooth technology
- Internal rechargeable battery, up to 100 hours between charges
- Nearly indestructible, made of same material as bullet-proof glass



Hands-Free Page Turner

### Universal Tablet Mount, Single

The perfect holder for most models of tablets. Clipping your tablet in place is easy and secure. No more resting your tablet on a stand, amp, floor, etc.

- Attaches to a standard 5/8" (16 mm) threaded stand

### Large Stand Move and Store Cart

- Holds eighteen Bravo Music Stands
- Large center pivot wheels for maneuverability
- Loads and unloads from both ends
- 14-gauge 1" x 1-1/2" (25 x 38 mm) and 16-gauge 7/8" (22 mm) steel tubing with 8" (203 mm) wheels and 5" (127 mm) heavy-duty casters
- Stores compactly in 27-1/2" x 68" (699 x 1727 mm) floor space. Allow 64-1/2" (1638 mm) for height with Bravo Music Stands

### Small Stand Move and Store Cart

- Holds nine Bravo Music Stands
- Two-wheel cart design allows transport up and down stairs
- 14-gauge 1" x 1-1/2" (25 x 38 mm) and 16-gauge 7/8" (22 mm) steel tubing with 8" (203 mm) heavy-duty wheels
- Stores compactly in 27-1/2" x 36" (699 x 914 mm) floor space. Allow 64-1/2" (1638 mm) for height with Bravo Music Stands



Universal Tablet Mount

Universal Tablet Mount (shown on traditional music stand)

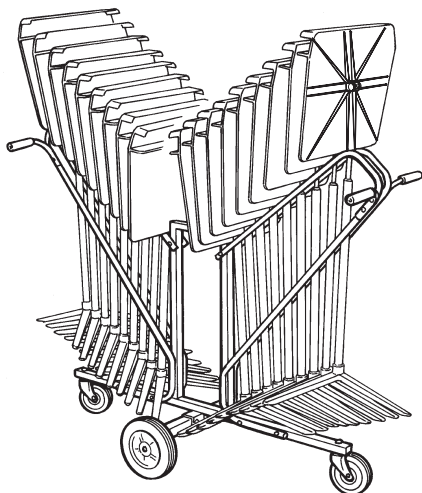

Large Move and Store Cart

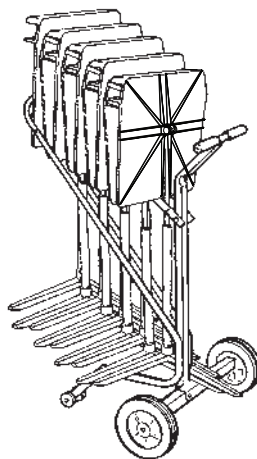

Small Move and Store Cart

Wenger

JRCLANCY

GEARBOSS

© 2024 Wenger Corporation  
USA/2024-03

#### Minnesota Location

Wenger Phone 800.4WENGER (493-6437) Wenger Worldwide +1.507.455.4100 | Parts & Service 800.887.7145 | wengercorp.com  
GearBoss Phone 800.493.6437 | gearboss.com  
555 Park Drive, PO Box 448 | Owatonna | MN 55060

#### New York Location

J.R. Clancy Phone 800.836.1885 JR Clancy Worldwide +1.315.451.3440 | jrclancy.com | 7041 Interstate Island Road | Syracuse | NY 13209