

4-Unit Cello Rack

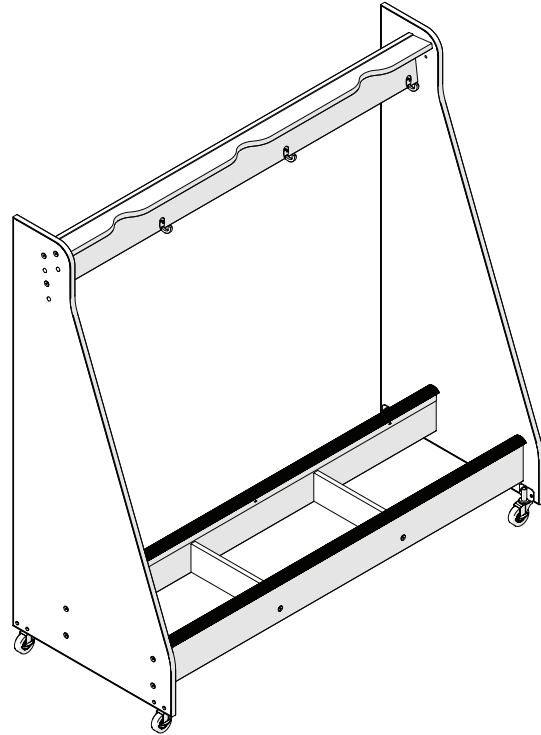

3-Unit String Bass Rack

### Contents

Important User Information .....	2	Fastener Parts List .....	3
General .....	2	Parts List .....	3
Manufacturer .....	2	Assembly .....	4
Intended Use .....	2	Operation .....	7
Warranty .....	2	Replacement Parts .....	8
Required Tools .....	2		

Visit the Instrument Storage Racks web page at [wengercorp.com](http://wengercorp.com) for more information.

- Note:** Please read and understand these instructions before starting the assembly.  
**Note:** If you need additional information, contact Wenger Corporation using the information below.  
**Note:** For easier assembly, two people are recommended.

# ***Important User Information***

---

## ***General***

Copyright © 2022 by Wenger Corporation

All rights reserved. No part of the contents of this manual may be reproduced, copied, or transmitted in any form or by any means including graphic, electronic, or mechanical methods or photocopying, recording, or information storage and retrieval systems without the written permission of the publisher, unless it is for the purchaser's personal use.

Printed and bound in the United States of America.

The information in this manual is subject to change without notice and does not represent a commitment on the part of Wenger Corporation. Wenger Corporation does not assume any responsibility for any errors that may appear in these instructions.

In no event will Wenger Corporation be liable for technical or editorial omissions made herein, nor for direct, indirect, special, incidental, or consequential damages resulting from the use or defect of these instructions. The manufacturer reserves the right to change this product at any time.

The information in this document is not intended to cover all possible conditions and situations that might occur. The end user must exercise caution and common sense when assembling or installing Wenger Corporation products. If any questions or problems arise, call the Wenger Corporation at (800) 4WENGER (493-6437) or +1-507-455-4100 worldwide.

## ***Manufacturer***

The Cello/Bass Storage Racks are manufactured by:

Wenger Corporation  
555 Park Drive  
Owatonna, MN 55060  
(800) 4WENGER (493-6437) • +1 (507) 455-4100  
wengercorp.com

## ***Intended Use***

- This product is intended for indoor use in normal ambient temperature and humidity conditions — it must not be exposed to prolonged outside weather conditions.
- This product is intended to be assembled and used only as described in these instructions.

## ***Warranty***

This product is guaranteed free of defects in materials and workmanship for five full years from date of shipment. A full warranty statement is available upon request.

# ***Required Tools***

---

The following tools are required for assembly.

- Plastic mallet
- Phillips head screwdriver or phillips head insert bit
- Variable speed drill (to drive hex socket screws)
- 5/32" (4 mm) hex insert bit (supplied)

## Fastener Parts List

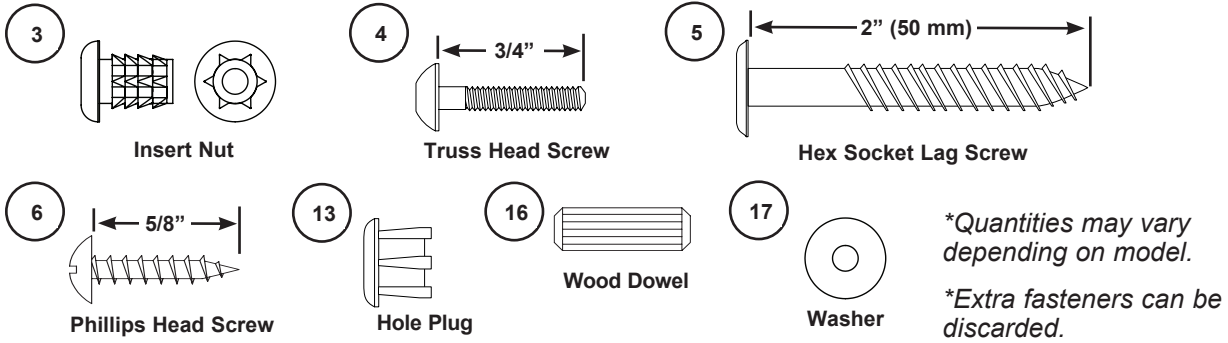

## Parts List

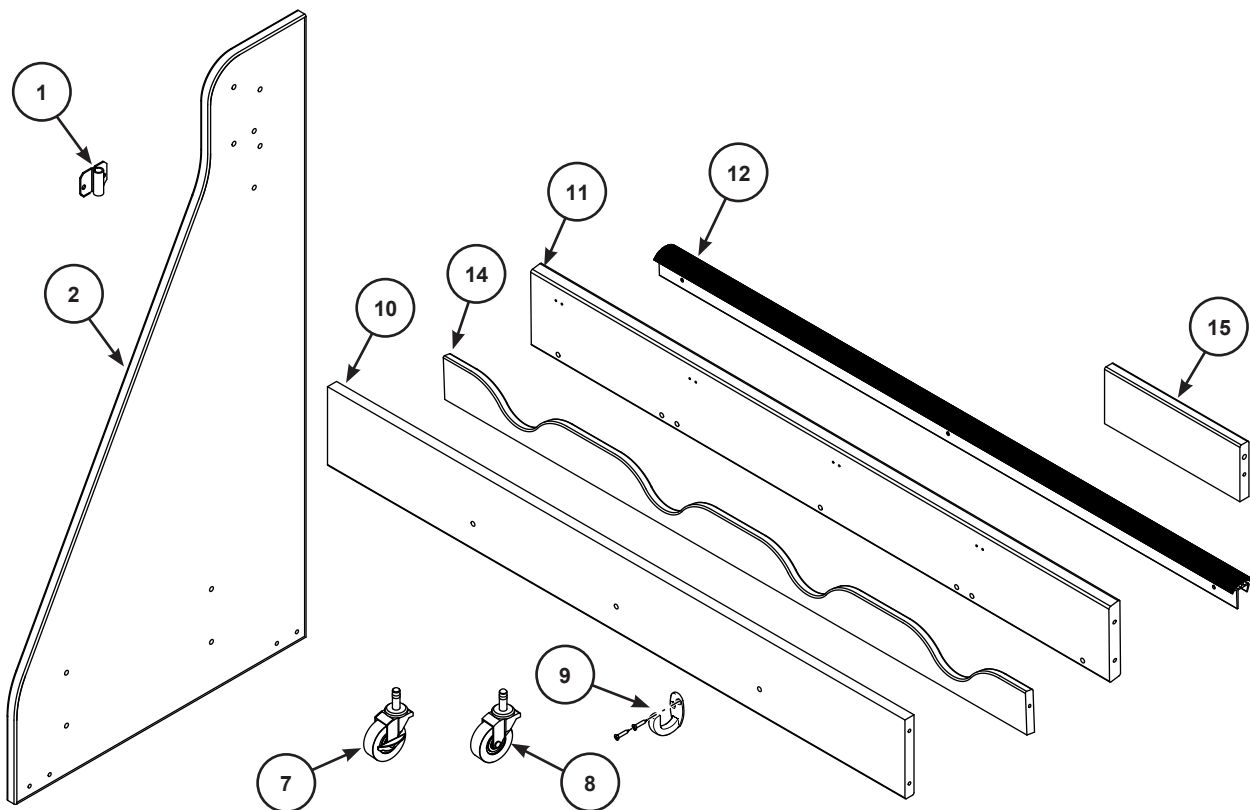

Item	Qty	Description	Item	Qty	Description	Item	Qty	Description
1	4	Bracket, caster	7	2	Caster, locking	13	12	Plug, hole, 5/16" diameter
2	2	Panel, end, right and left	8	2	Caster, non-locking	14	1	Panel, top, neck support
3	8	Nut, insert	9	3-6	Hook, brass, with screws	15	2-5	Panel, divider
4	8	Screw, truss-head, 3/4"	10	2	Panel, base	16	9-17	Dowel, wood
5	23-30	Screw, lag, hex socket, 2" (50 mm)	11	1	Panel, top, cross support	17	9	Washer, flat, 3/16" ID x 1/2" OD
6	7	Screw, phillips head, 5/8"	12	2	Extrusion, string rack			

\*Pre-drilled holes may vary by size and model.

\*Quantities may vary depending on model.

\*Extra fasteners can be discarded.

# Assembly

---

1. Assemble the base support.  
Quantities of divider panels, wood dowels and hex head lag screws may vary depending on model.
  - a. With the edge banded surface facing up, insert one wood dowel (#16) into the top hole on each end of the three divider panels (#15). **(Detail A)**
  - b. With the base panel (#10) edge banded surfaces facing down, insert the wood dowel end of each divider panel (#15) into the top hole on the inside surface of each base panel. **(Detail A)**
  - c. Secure both base panels (#10) to the divider panels (#15) using one 50 mm (2") hex socket lag screws (#5) in each side. **(Detail A)**

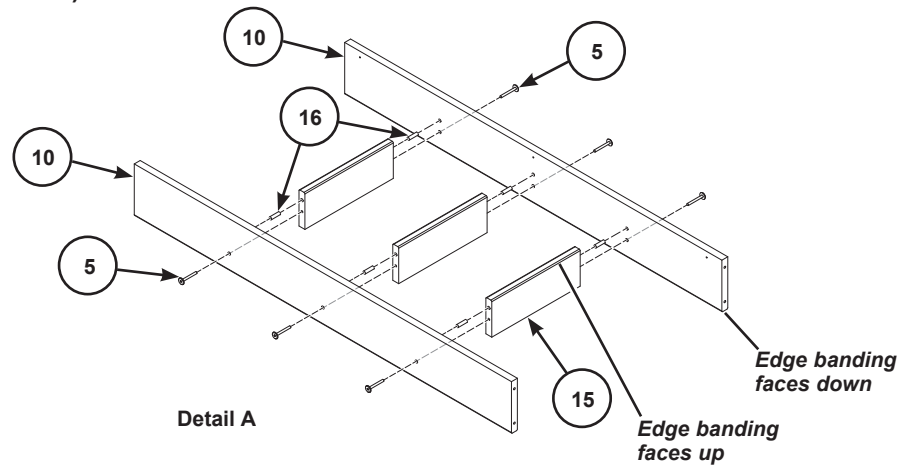

2. Place one string rack extrusion (#12) over each of the non-edge banded surfaces at the front and back of the base panel assembly. Secure to the inside surface using three 5/8" phillips head screws (#6) in each. **(Detail B)**

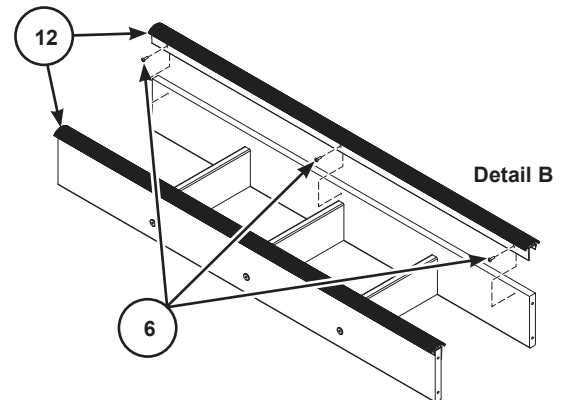

## Assembly (continued)

3. Pound two insert nuts (#3) into each rear corner of the end panels (#2) to make a left-hand and a right-hand side as shown. **(Detail C)**

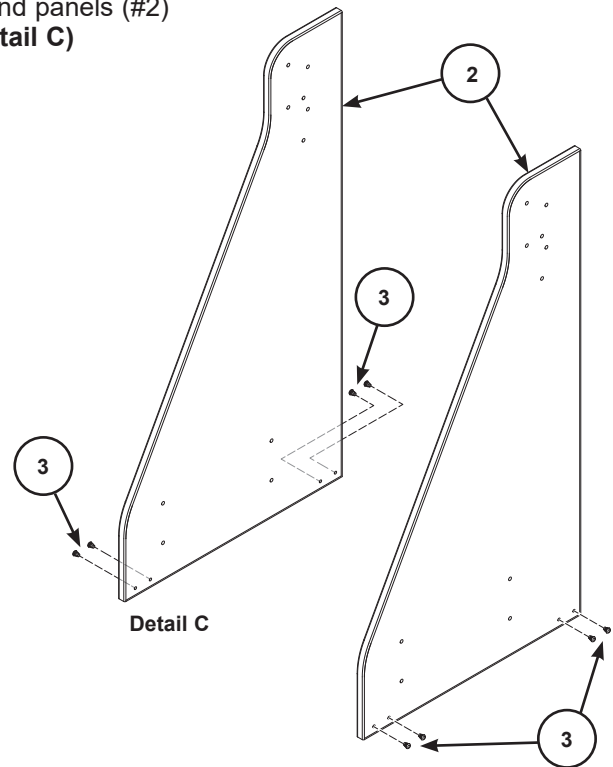

4. Attach caster brackets (#1) to the inside corners of the end panels (#2) with 3/16" ID x 1/2" OD washers (#17) and 3/4" truss head screws (#4). **(Detail D)**

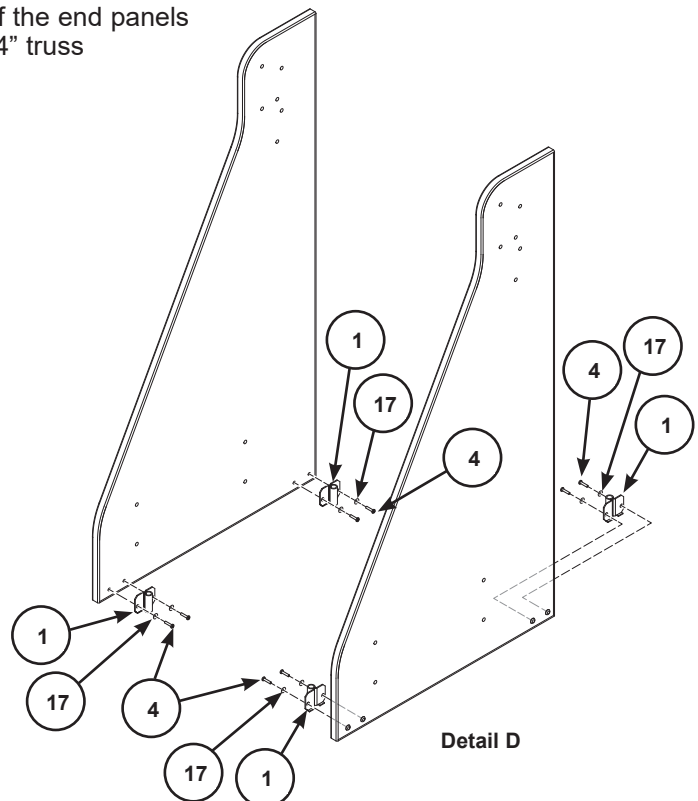

## Assembly (continued)

5. Attach the base support assembly to both end panels (#2) using four hex socket lag screws (#5) in each from the outside of the end panels as shown. **(Detail E)**

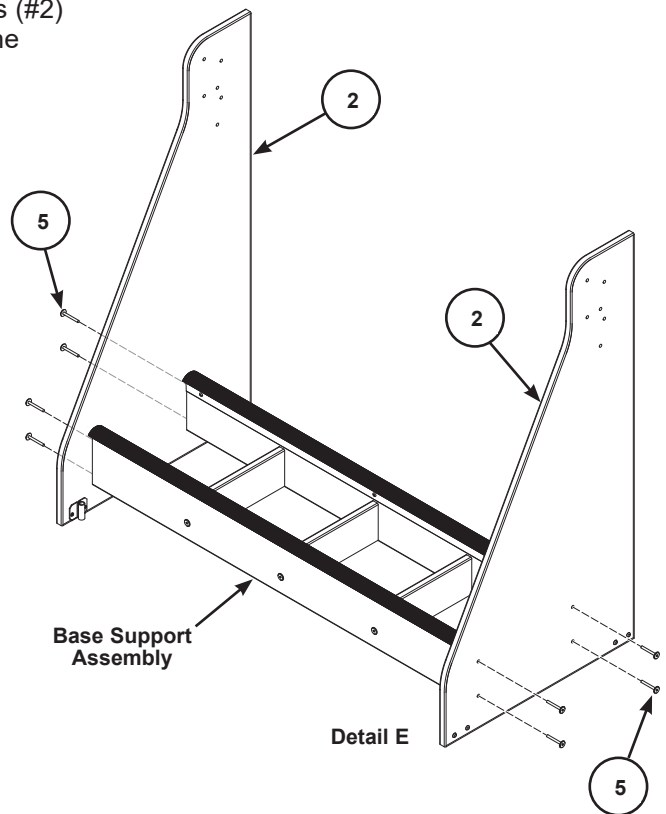

6. Assemble top cross support.  
Quantities of wood dowels (#16) and hex head lag screws (#5) may vary depending on model.
- Insert wood dowels (#16) into the neck support top panel (#14). **(Detail F)**
  - Secure the neck support top panel (#14) with wood dowels (#16) to the cross support top panel (#11) using 50 mm (2") hex socket lag screws (#5). **(Detail F)**

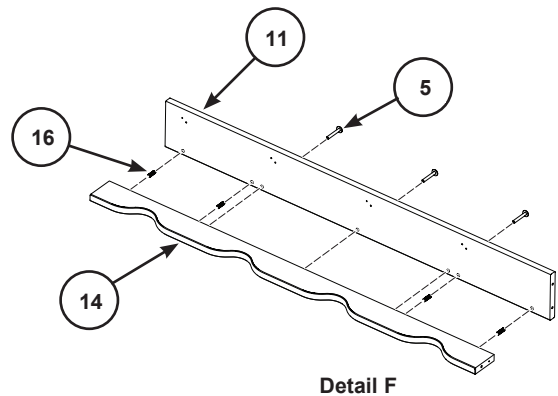

- Attach the brass hooks (#9) with the supplied brass screws to the top cross support panel (#11).  
Quantity may vary depending on model. **(Detail G)**

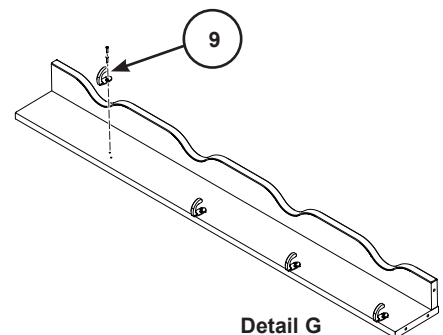

## Assembly (continued)

7. Attach the top cross support assembly to both end panels (#2) using three hex head lag screws (#5) using the upper set of holes in each side.

Plug the unused holes on both the inside and outside surfaces using hole plugs (#13). (Detail H)

**Note:** For 1/2 size cellos and basses, use the lower set of holes labeled "B" to attach the top cross support assembly. (Detail I)

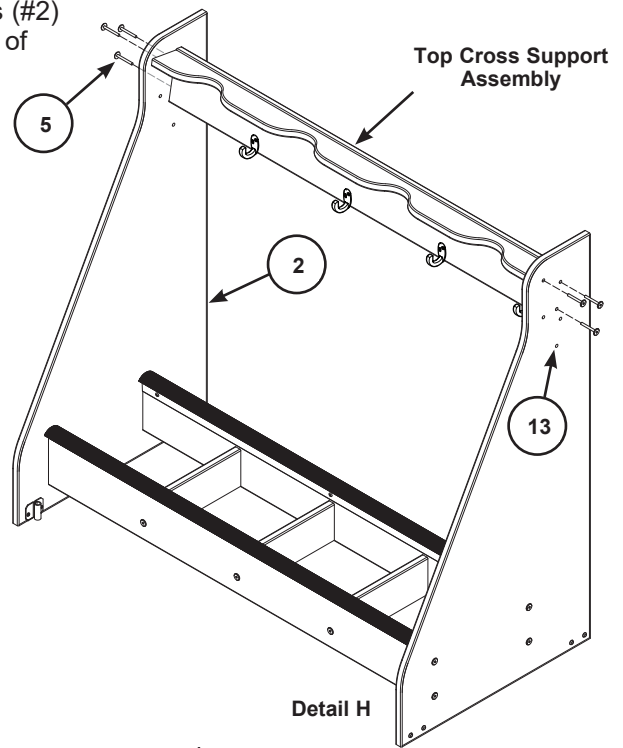
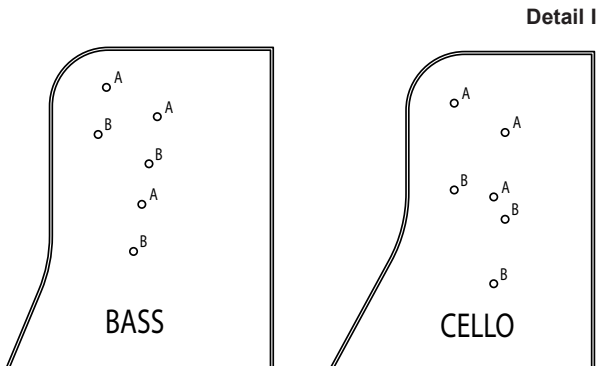

8. Pound in the two locking casters (#7) into the front caster brackets (#1) and the two non-locking casters (#8) into the back caster brackets (#1). (Detail J)

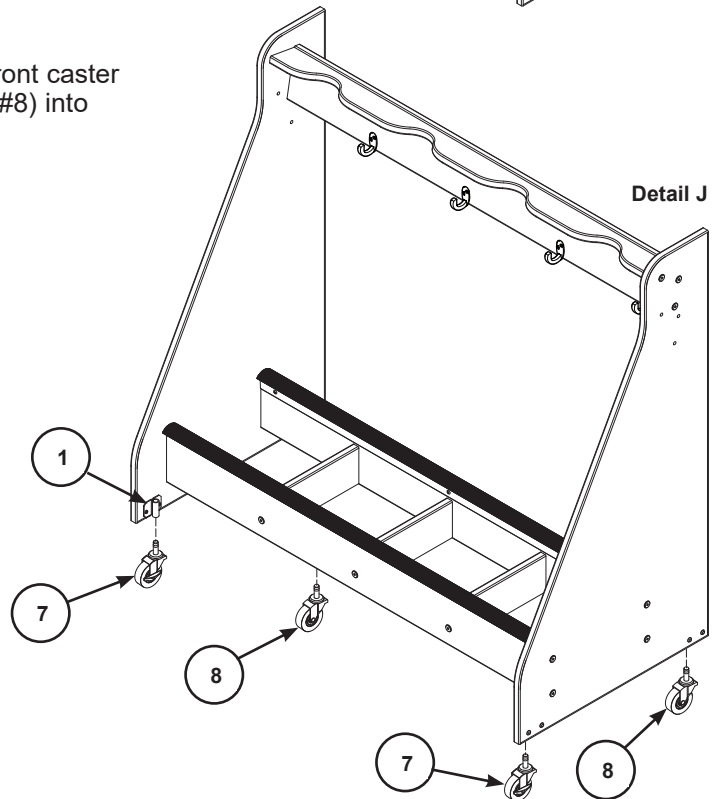

## Operation

Before placing instruments on the mobile rack, be sure the casters are in the locked position. Unlock the casters to move the rack. Two people are recommended to move the rack. Move the rack slowly and carefully making sure the instruments stay in place during transport.

# Replacement Parts

Item	Qty	Description	Item	Qty	Description	Item	Qty	Description
1	4	Bracket, caster	7	2	Caster, locking	13	12	Plug, hole, 5/16" diameter
2	2	Panel, end, right and left	8	2	Caster, non-locking	14	1	Panel, top, neck support
3	8	Nut, insert	9	3-6	Hook, brass, with screws	15	2-5	Panel, divider
4	8	Screw, truss-head, 3/4"	10	2	Panel, base	16	9-17	Dowel, wood
5	23-30	Screw, lag, hex socket, 2" (50 mm)	11	1	Panel, top, cross support	17	9	Washer, flat, 3/16" ID x 1/2" OD
6	7	Screw, phillips head, 5/8"	12	2	Extrusion, string rack			

