

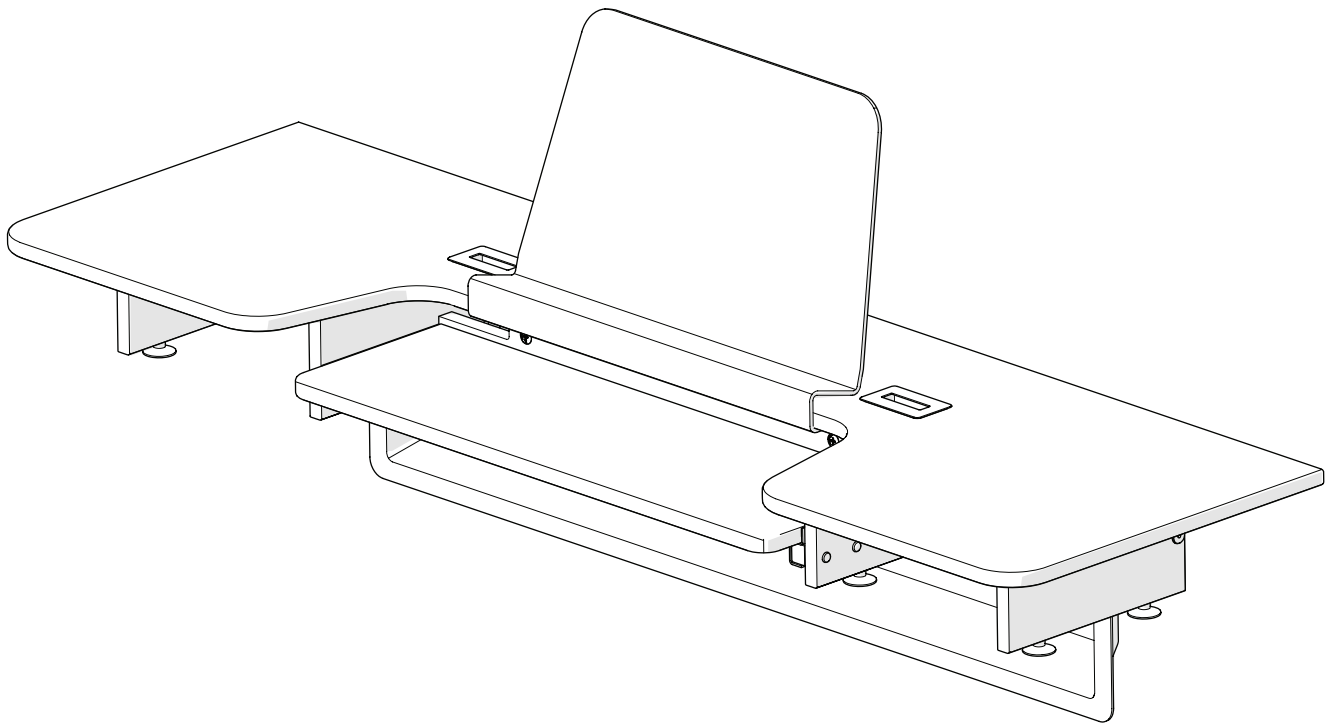

# Assembly Instructions Class Piano Workstation



## Contents

Important User Information .....	2	Assembly .....	4
Required Tools .....	3		
Parts List .....	3		

Visit the Class Piano Workstation web page at [wengercorp.com](http://wengercorp.com) for more information.

**Note:** Please read and understand these instructions before starting the assembly.

**Note:** If you need additional information, contact Wenger Corporation using the information below.

# ***Important User Information***

---

## ***General***

Copyright © 2022 by Wenger Corporation

All rights reserved. No part of the contents of this manual may be reproduced, copied, or transmitted in any form or by any means including graphic, electronic, or mechanical methods or photocopying, recording, or information storage and retrieval systems without the written permission of the publisher, unless it is for the purchaser's personal use.

Printed and bound in the United States of America.

The information in this manual is subject to change without notice and does not represent a commitment on the part of Wenger Corporation. Wenger Corporation does not assume any responsibility for any errors that may appear in these instructions.

In no event will Wenger Corporation be liable for technical or editorial omissions made herein, nor for direct, indirect, special, incidental, or consequential damages resulting from the use or defect of these instructions.

The manufacturer reserves the right to change this product at any time.

The information in this document is not intended to cover all possible conditions and situations that might occur. The end user must exercise caution and common sense when assembling or installing Wenger Corporation products. If any questions or problems arise, call the Wenger Corporation at (800) 4WENGER (493-6437) or +1-507-455-4100 worldwide.

## ***Manufacturer***

The Class Piano Workstation is manufactured by:

Wenger Corporation  
555 Park Drive  
Owatonna, MN 55060  
(800) 4WENGER (493-6437) • +1 (507) 455-4100  
wengercorp.com

## ***Intended Use***

- This product is intended for indoor use in normal ambient temperature and humidity conditions — it must not be exposed to prolonged outside weather conditions.
- This product is intended to be assembled and used only as described in these instructions.

## ***Warranty***

This product is guaranteed free of defects in materials and workmanship for five full years from date of shipment. A full warranty statement is available upon request.

## Required Tools

The following tools are required for assembly.

- Phillips head screwdriver
- 4 mm hex wrench (supplied) *if installing on a 76-key piano*

## Parts List

Item	Qty	Description
1	1	Workstation Desk
2	8	Suction Cup
3	2	Wire Grommet
4	1	Power Strip and Mounting Plate
5	1	Plastic Rear Cover
6	4	#8-32 x 3/4" Machine Screw
7	1	Music Holder

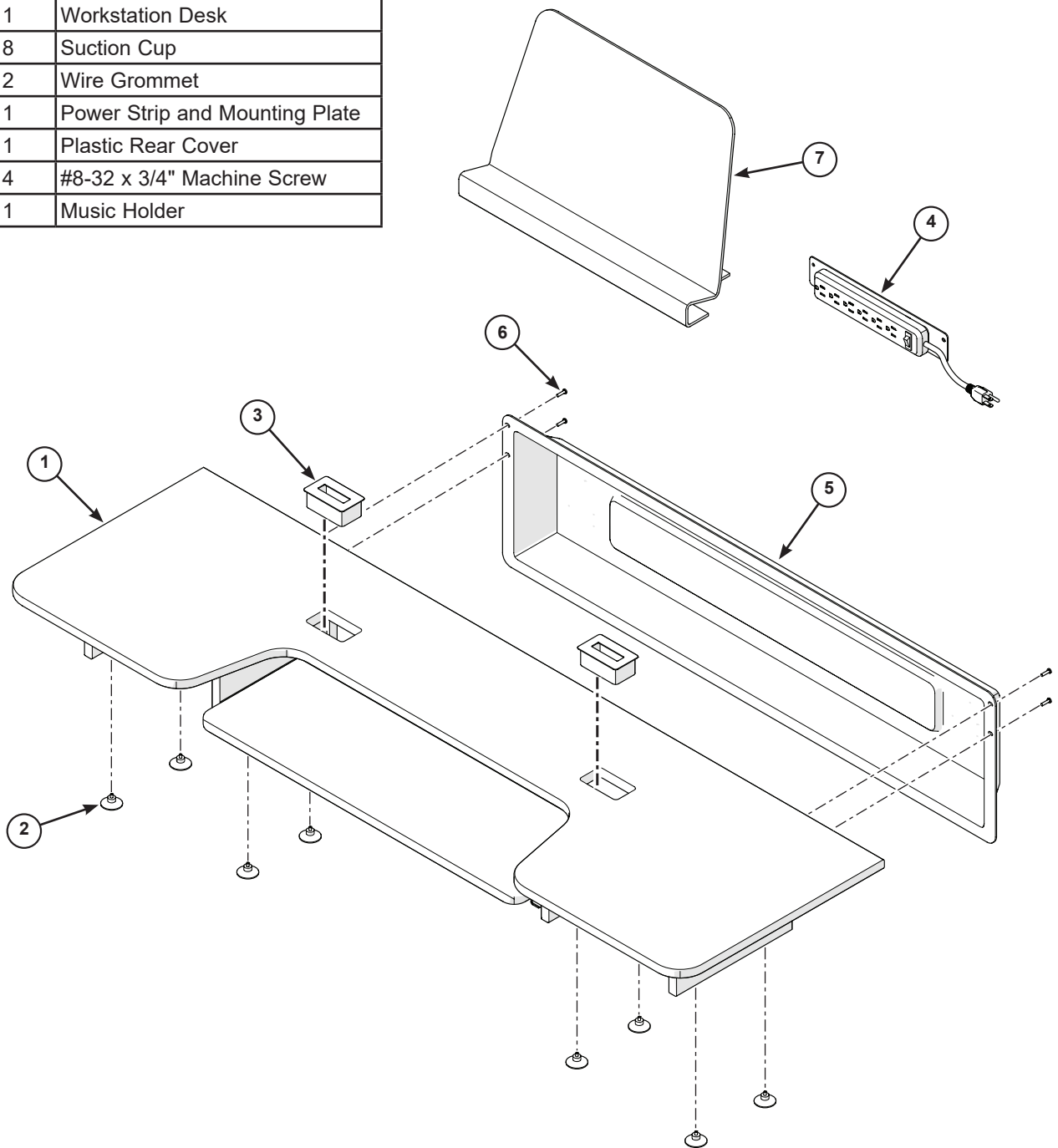

# Assembly

---

1. Screw eight suction cups (2) into the inserts on the bottom side of the workstation desk (1). Tighten securely.

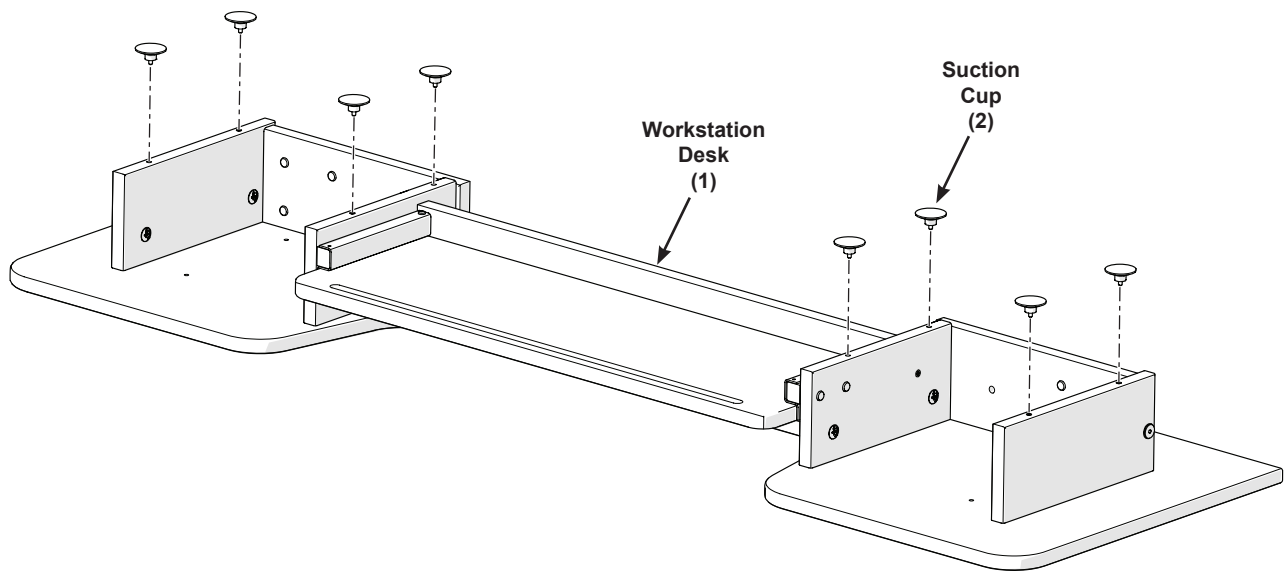

2. Insert two wire grommets (2) into the slots on the top side of the workstation desk.

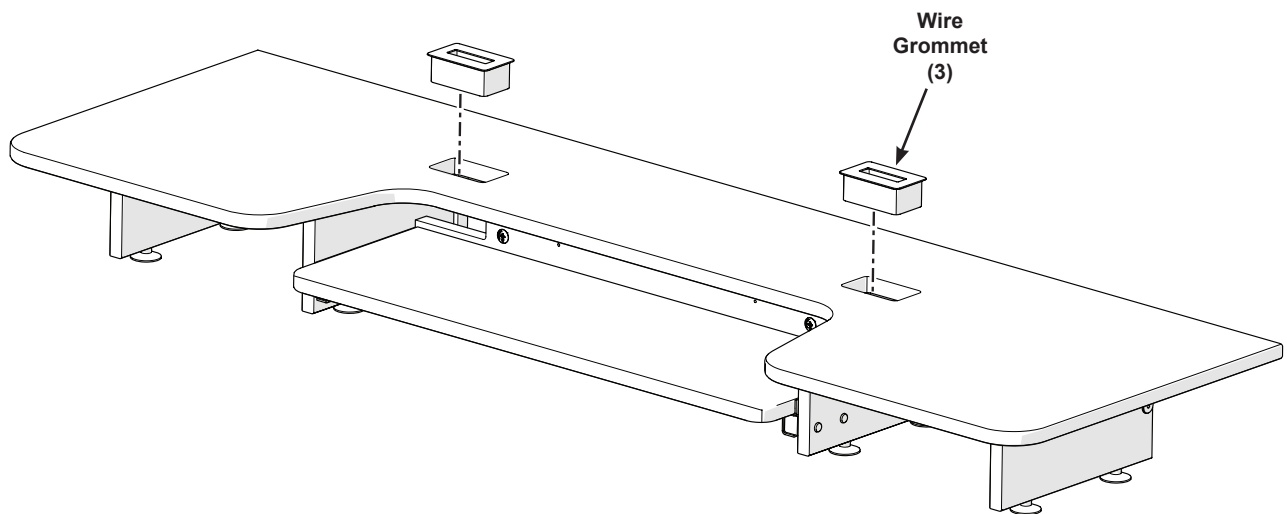

## Assembly (continued)



The Class Piano Workstation is shipped to fit on top of a 88-key digital piano.  
To fit on top of a smaller 76-key digital piano, the end support panels can be moved in.  
To move the end support panels, follow the step below before proceeding.  
Otherwise skip ahead to the next page.

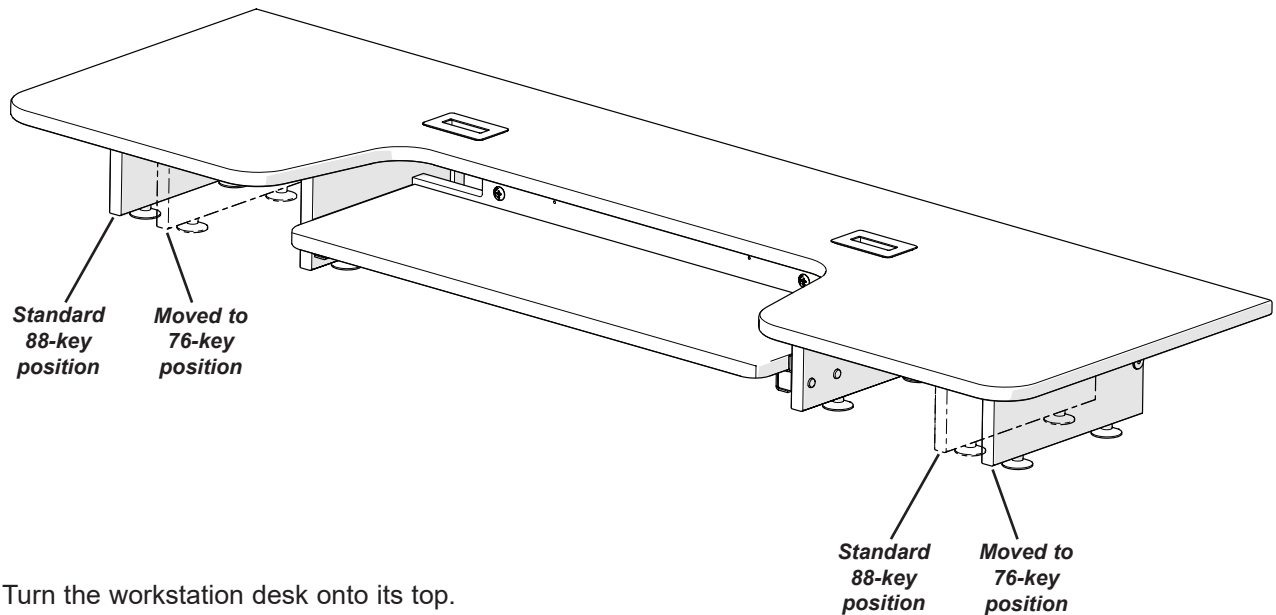

3. Turn the workstation desk onto its top.

**On both end support panels:**

- Turn and unlock the two cam connectors in the side panel.
- Remove the hex socket screw from the back panel.
- Lift the end support panels off the connecting bolts
- Move the connecting bolts to the inner set of holes.
- At the new location, place the end support panels onto the connecting bolts and reattach.

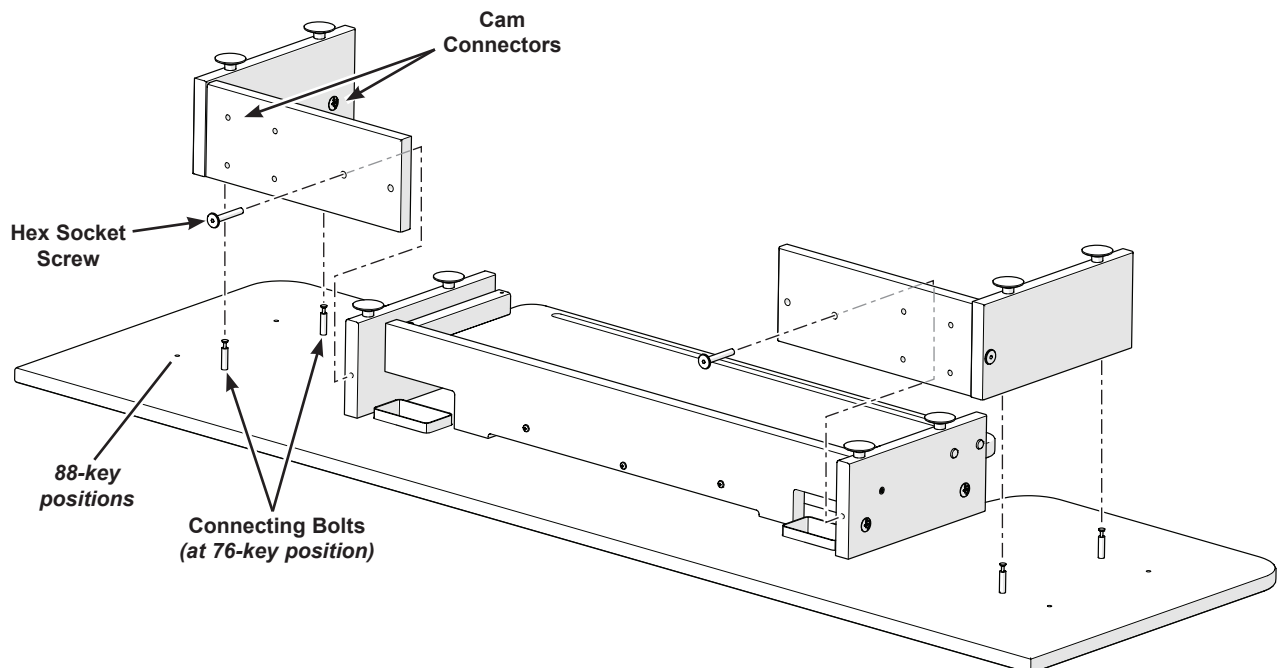

## ***Assembly (continued)***

---

4. Set the workstation desk to fit on top of the piano as shown.  
Press down firmly to secure the suction cups

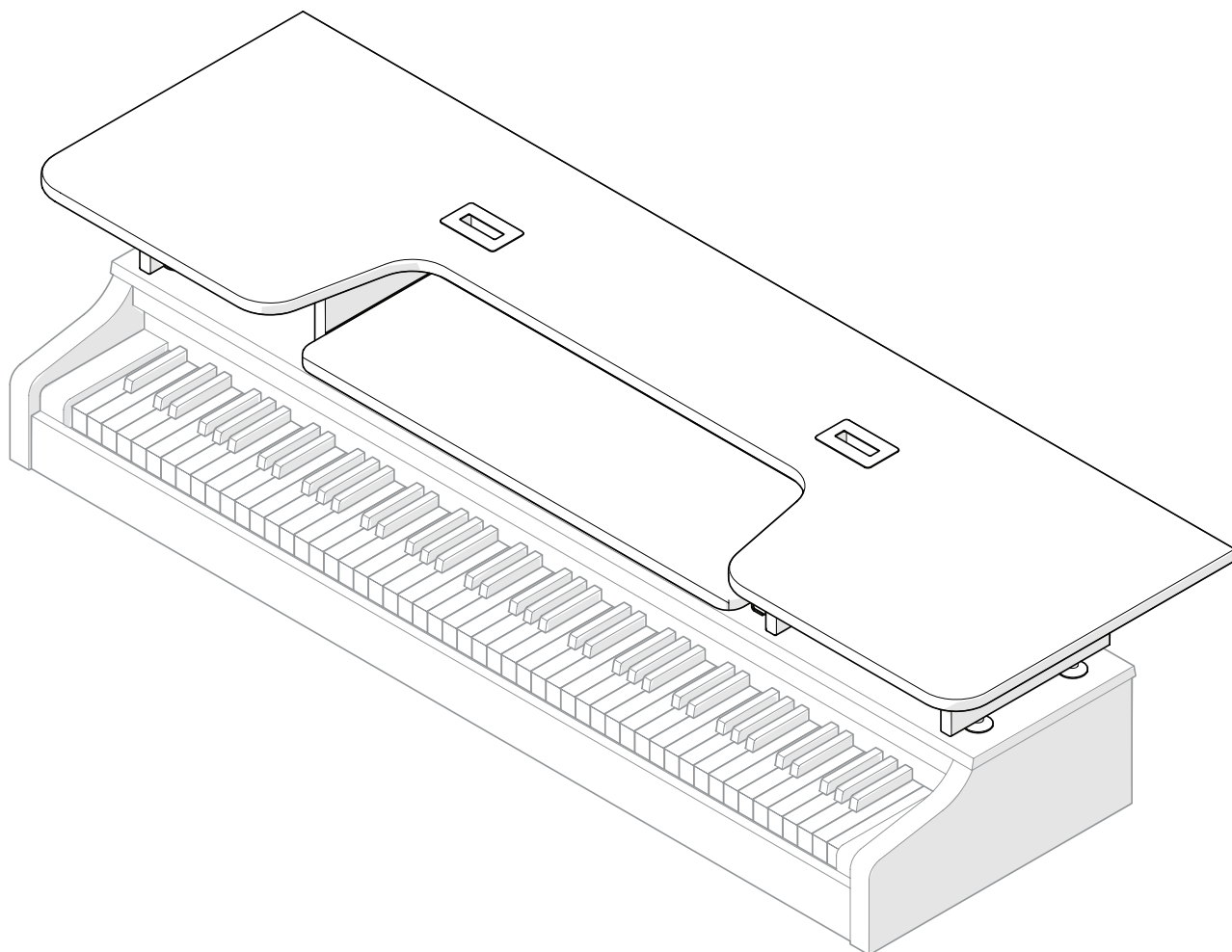

## Assembly (continued)

---

5. Wires, cords and cables can all be fed through the wire grommets. There is a power strip (4) mounted on the back side of the workstation desk under the desk surface.

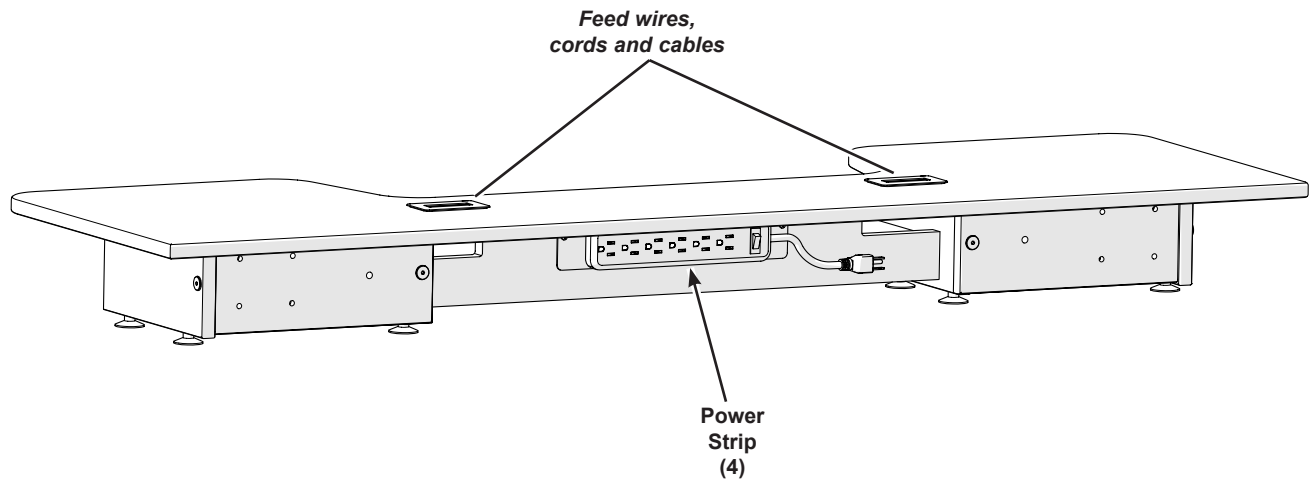

6. Attach the plastic rear cover (5) to the pilot holes at the back side of the workstation desk using four #8-32 x 3/4" Machine Screws (6).

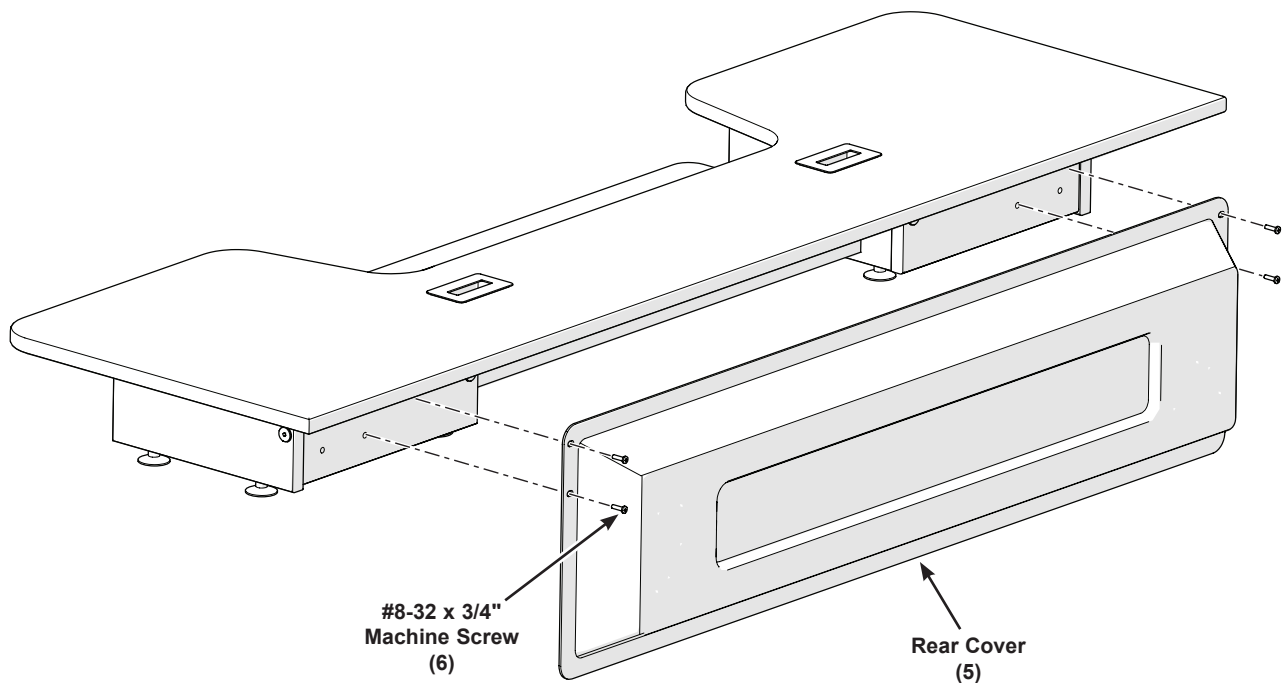

# Assembly (continued)

---

7. Slide the music holder (7) over the front edge of the upper desk surface as shown.

