



Assembly Instructions

Work Surface Mount Accessory

for Flex® TechBridge

Basic Instructions to be used with the Work Surface Mount Accessory for Flex® TechBridge only!
For other component information, refer to the Flex TechBridge Owner's Manual 236A153.

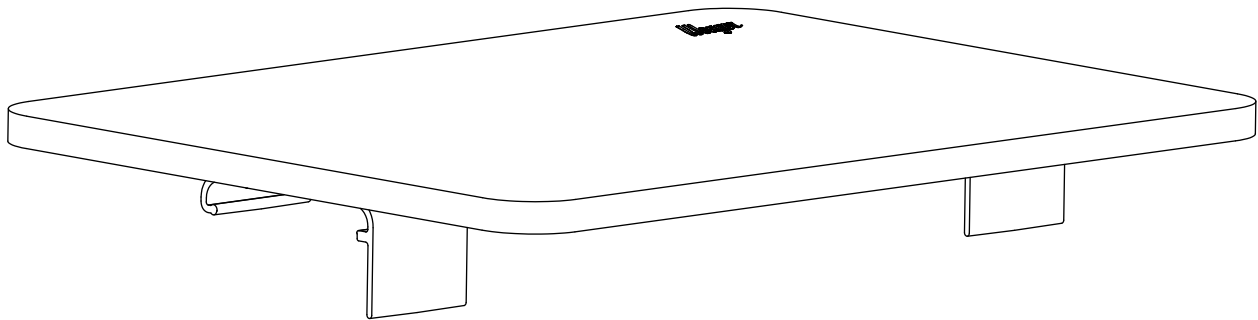

Work Surface Mount
Accessory

Parts List

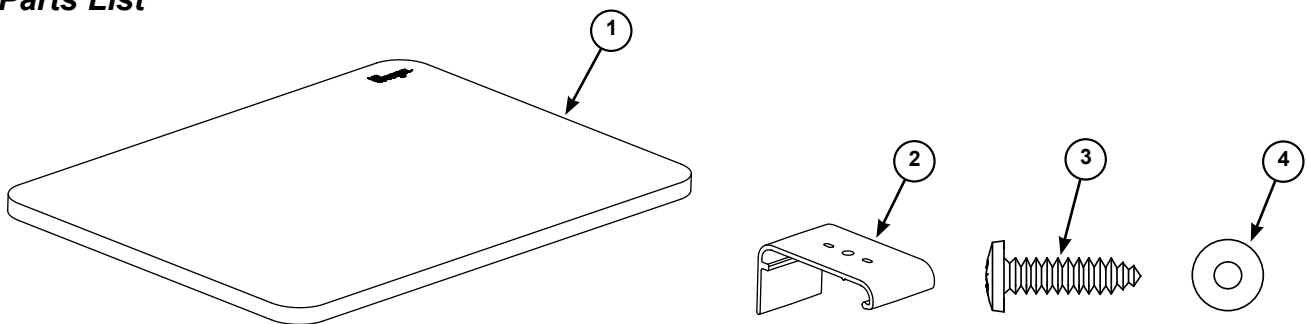

Item	Qty	Description	Item	Qty	Description
1	1	Work Surface	3	4	Screw, #10-3/4"
2	2	Bridge Clip	4	4	Flat Washer, 0.188 ID x 0.734 OD

Note: Please read and understand these instructions before assembling.

Note: If you need additional information, contact Wenger Corporation using the information below.

Assembly

1. Align the bridge clip (2) with the pilot holes located at the bottom side of the work surface (1) and attach it using two #10-3/4" screws (3) and 0.188 ID x 0.734 OD flat washers (4) as shown.
2. Repeat to attach the second bridge clip.

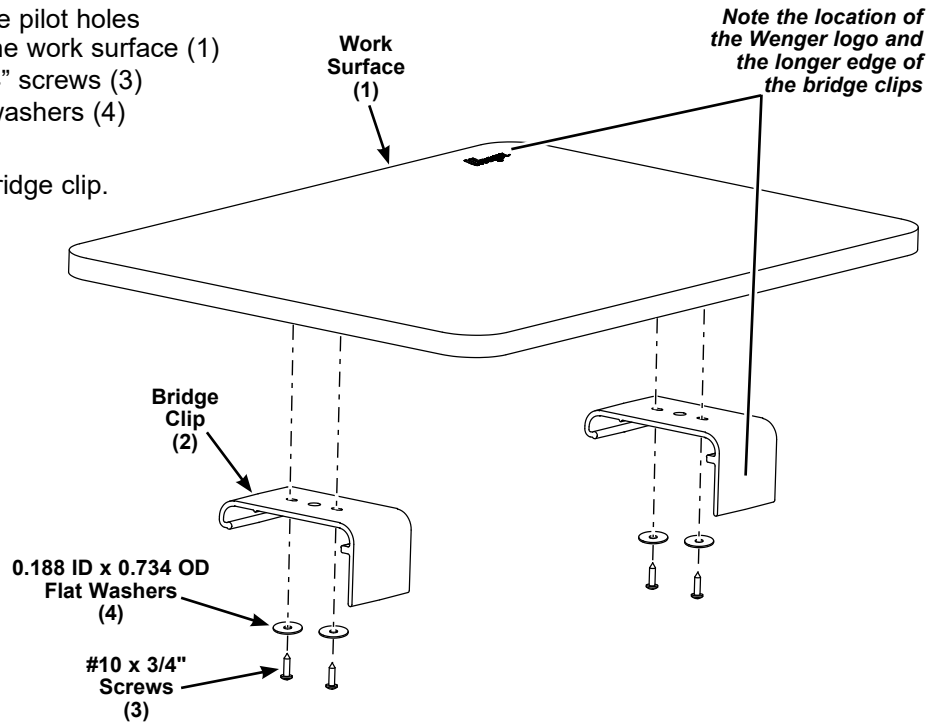

4. Attach the assembled work surface mount to the bridge extrusion by inserting the short sides of the bridge clips into the outside groove. Press down to snap the long sides of the bridge clips into place.
5. To reposition or remove the work surface mount, release the bridge clips by pulling on the release handle (long side of the clip) and rotate forward.

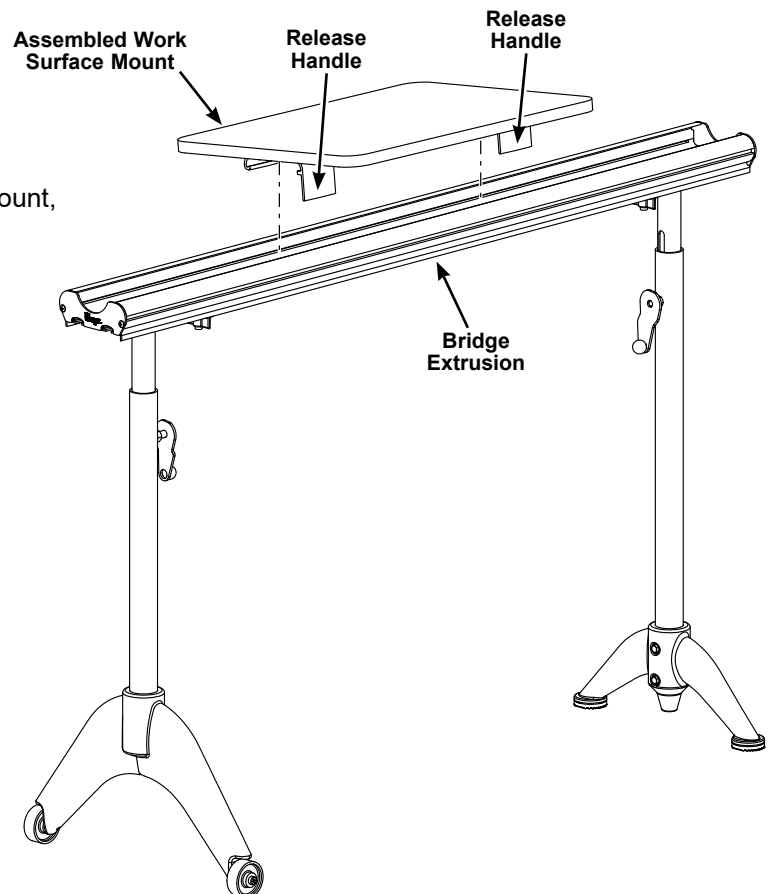

CAUTION
Always load the work surface evenly.