

flipFORMS®

- 025D002 blue/grey, 025D003 green/grey, 025D004 yellow/grey, 025D005 red/grey, 025D027 grey/grey, 025D028 black/black (100 lb) (45 kg)
- Designed for maximum load of 125 lb/ft² (610 kg/m²)
- Takes on three basic shapes for use as a one tier platform, two tier or three tier unit
- Has two movable sections hinged onto a core unit
 - Flip larger back section onto core for two tiers
 - Flip both back and front sections onto core unit for three tiers; when both sections are down, flipFORMS can be used as a one tier raised platform
- Blow molded, high-density polyethylene plastic shell provides an easy-to-clean surface that's super tough
- Shell has skid resistant texture molded into surface for added safety and sure-footedness
- Replaceable tops
- Recessed, molded handholds on front and sides for easy positioning or carrying
- Built-in wheels in reinforced wheel pockets provide one-person portability
- Units store in an upright position
- Twelve 1-1/2" (38 mm) square skid-resistant, non-marring glides positioned on the bottom of the unit; secured by recessed screws
- Patented hinge design maintains flat surface in all positions
- Ten-year warranty

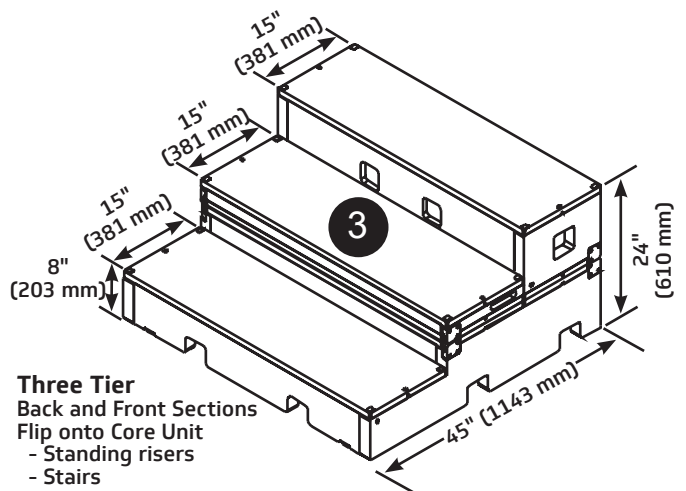
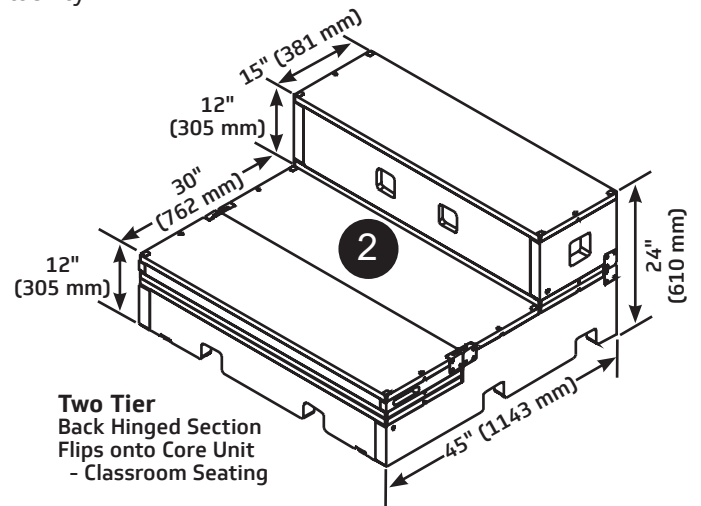
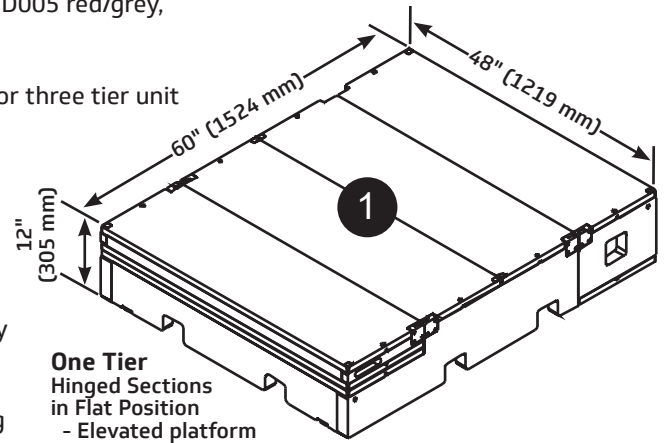

Grade Level	2-Step Tiered Seating Capacity	3-Step Riser Capacity*
Grades 1-3	8 students/unit	16 students/unit
Grades 4-6	6 students/unit	12 students/unit

*Capacity using the floor as the front row

