

Bravo® Stand

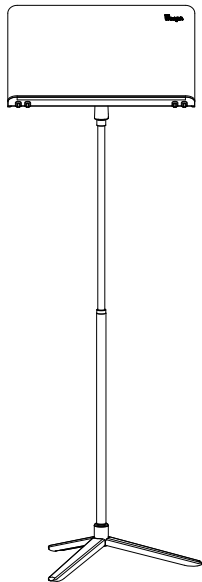

Roughneck® Stand



Classic 50® Stand

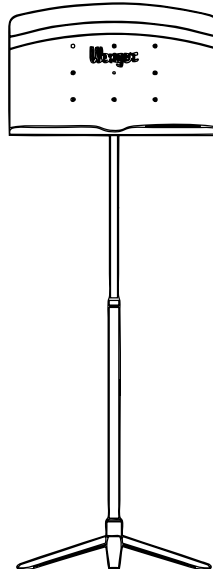

Preface® Stand

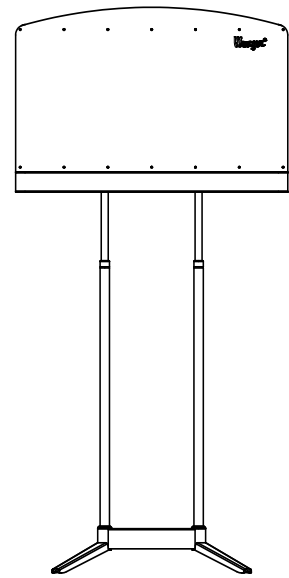

Preface® Conductor's Stand

## Contents

Important User Information .....	2	Assembly .....	4
General .....	2	Base and Slider Assembly .....	4
Manufacturer .....	2	Desk and Slider Assembly .....	5
Intended Use .....	2	Operation .....	7
Warranty .....	2	Storage .....	8
Required Tools .....	3	Maintenance .....	8
Parts List .....	3		



Visit the Music Stands web page at [wengercorp.com](http://wengercorp.com) for more information.

**Note:** Please read and understand these instructions before assembling or using.

**Note:** If you need additional information, contact Wenger Corporation using the information below.

# ***Important User Information***

---

## ***General***

Copyright © 2018 by Wenger Corporation

All rights reserved. No part of the contents of this manual may be reproduced, copied, or transmitted in any form or by any means including graphic, electronic, or mechanical methods or photocopying, recording, or information storage and retrieval systems without the written permission of the publisher, unless it is for the purchaser's personal use.

Printed and bound in the United States of America.

The information in this manual is subject to change without notice and does not represent a commitment on the part of Wenger Corporation. Wenger Corporation does not assume any responsibility for any errors that may appear in these instructions.

In no event will Wenger Corporation be liable for technical or editorial omissions made herein, nor for direct, indirect, special, incidental, or consequential damages resulting from the use or defect of these instructions. The manufacturer reserves the right to change this product at any time.

The information in this document is not intended to cover all possible conditions and situations that might occur. The end user must exercise caution and common sense when assembling or installing Wenger Corporation products. If any questions or problems arise, call the Wenger Corporation at (800) 4WENGER (493-6437) or +1-507-455-4100 worldwide.

## ***Manufacturer***

The Music Stands are manufactured by:

Wenger Corporation  
555 Park Drive  
Owatonna, MN 55060  
(800) 4WENGER (493-6437) • +1 (507) 455-4100  
wengercorp.com

## ***Intended Use***

- This product is intended for indoor use in normal ambient temperature and humidity conditions — it must not be exposed to prolonged outside weather conditions.
- This product is intended to be assembled only as described in these instructions.

## ***Warranty***

This product is guaranteed free of defects in materials and workmanship for five full years from date of shipment. A full warranty statement is available upon request.

## Required Tools

The following tools are needed to assemble the Music Stands:

- Plastic or Wood Mallet
- 7/16" (11 mm) Box End or Socket Wrench
- 5/32" (4 mm) Hex Key Wrench

### **CAUTION**

**Only use hand tools for assembly. Power tools could damage the components.**

## Parts List

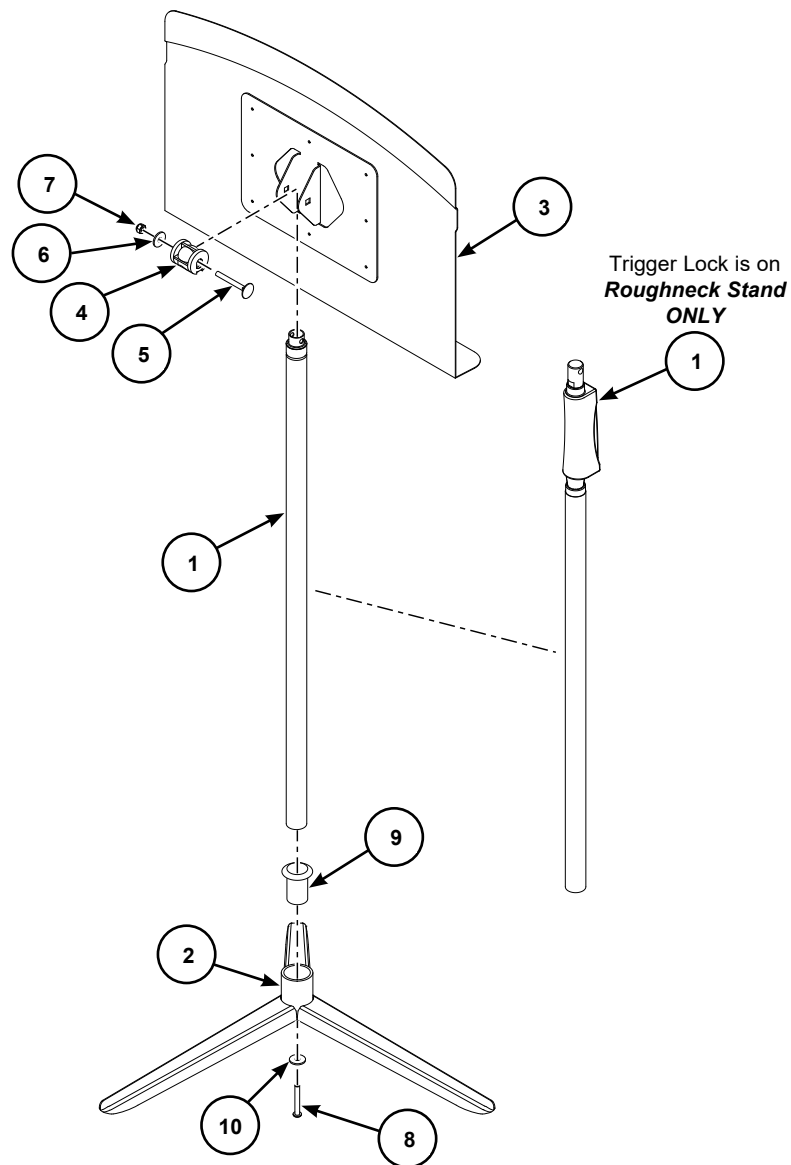

Item	Qty	Description	Item	Qty	Description
1	1	Slider Assembly	6	1	Washer, 1/4" ID x 1" OD
2	1	Base Assembly	7	1	Lock Nut, Flange, BZ, 1/4-20"
3	1	Desk	8	1	Socket Screw, BHD, 1/4-20 x 1.25"
4	1	Pivot Hub	9	1	Bushing Insert ( <b>Roughneck and Preface Stands ONLY</b> )
5	1	Elevator Bolt, 1/4-20 x 2"	10	1	Washer, 1/4" ID x 1" OD ( <b>Classic 50 Stand ONLY</b> )

# Assembly

## Base and Slider Assembly

If Assembling Roughneck or Preface Stands, begin at Step 1,  
If Assembling Bravo or Classic 50 Stands, skip to Step 2.

### CAUTION

Only use hand tools for assembly.  
Power tools could damage the components.

1. Slide the Bushing Insert into the Base Assembly.  
If necessary, tap the Bushing Insert with a plastic or wood mallet to ensure it is seated tightly in the Base Assembly.

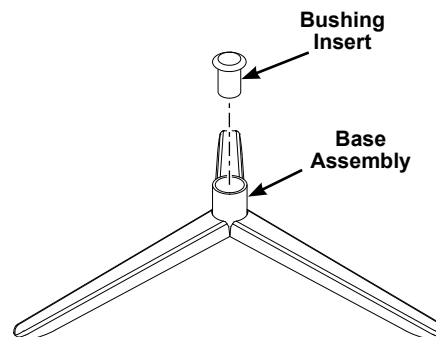

Roughneck and Preface Stands ONLY

2. Push the Slider Assembly into the Base Assembly.  
The Base Assembly may be tapped with a plastic or wood mallet until the Slider Assembly is flush with the bottom of the Base Assembly.

### CAUTION

Do not allow the Inner Tube to strike the ground.  
Do not force the Slider Assembly into the  
Base Assembly.  
Damage to the components could occur.

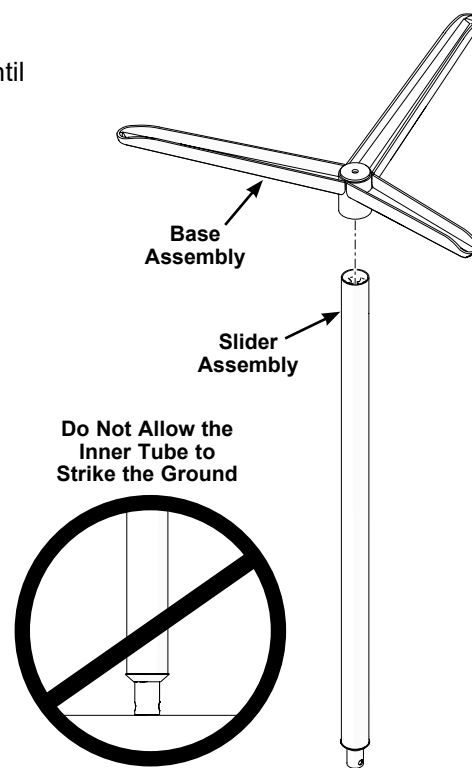

If Assembling Classic 50 Stands ONLY, go to Step 3,  
For ALL other stands, skip to Step 4.

3. Place a 1/4" ID x 1" OD Washer on the 1/4-20 x 1.25" Socket Screw.
4. Attach the Base Assembly to the Slider Assembly using a 1/4-20 x 1.25" Socket Screw.  
Tighten the Socket Screw using a 5/32" (4mm) hex key wrench until the Slider Assembly no longer rotates inside of the Base Assembly.

**Note:** If assembling a Preface Conductor's Stand, follow these steps for both of the Base and Slider Assemblies.

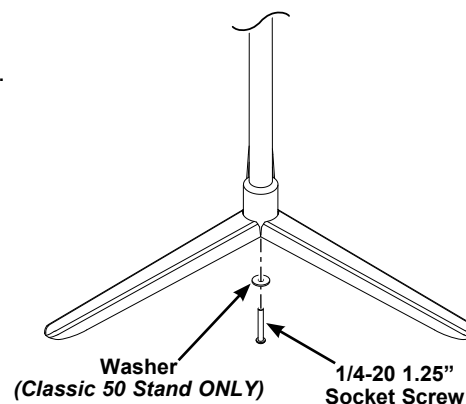

## Assembly (continued)

---

### Desk and Slider Assembly

1. Extend the inner tube of the Slider Assembly 3" to 4" (76 to 102 mm) to ease installation of the Pivot Hub. Insert an Allen Wrench through the holes at the end of the inner tube and use as a handle to extend the tube. A pair of pliers may also be used to grasp the wall of the inner tube to aid in extending it.



2. Place the Pivot Hub over the Tube Assembly and align the holes in both.

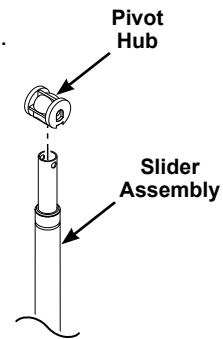

3. Slide the Desk over the Pivot Hub and Tube Assembly with all sets of holes aligned.

**Note:** If assembling a Roughneck Stand, the Trigger Lock will face toward the Desk.

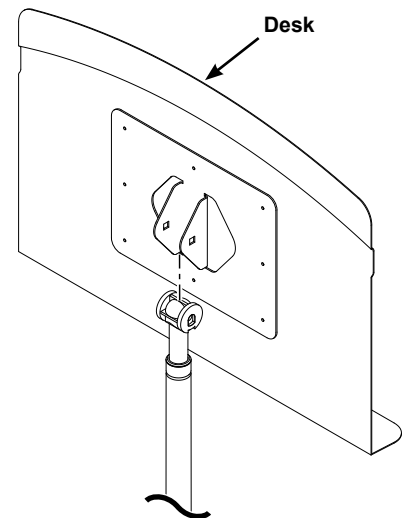
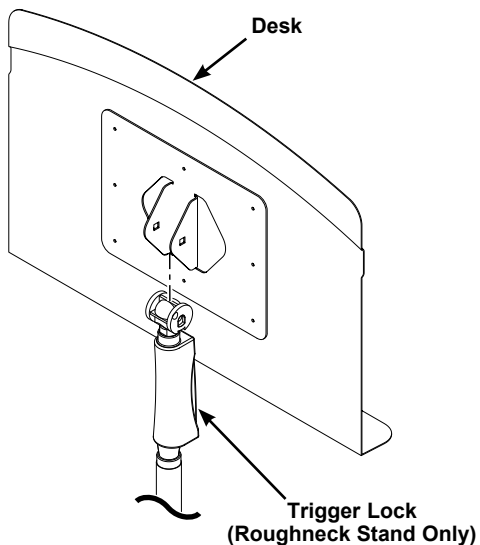

## **Assembly (continued)**

---

### **Desk and Slider Assembly (continued)**

- Slide the 1/4-20 x 2" Elevator Bolt through the aligned holes.

**Be sure that the square shoulder of the Elevator Bolt slips into the square hole of the Desk Flange or the Desk will not tighten properly.**

Attach with the 1/4" ID x 1" OD Washer and 1/4-20" Lock Nut using a 7/16" (11 mm) box-end or socket wrench to adjust the desk pivot tension, as necessary.

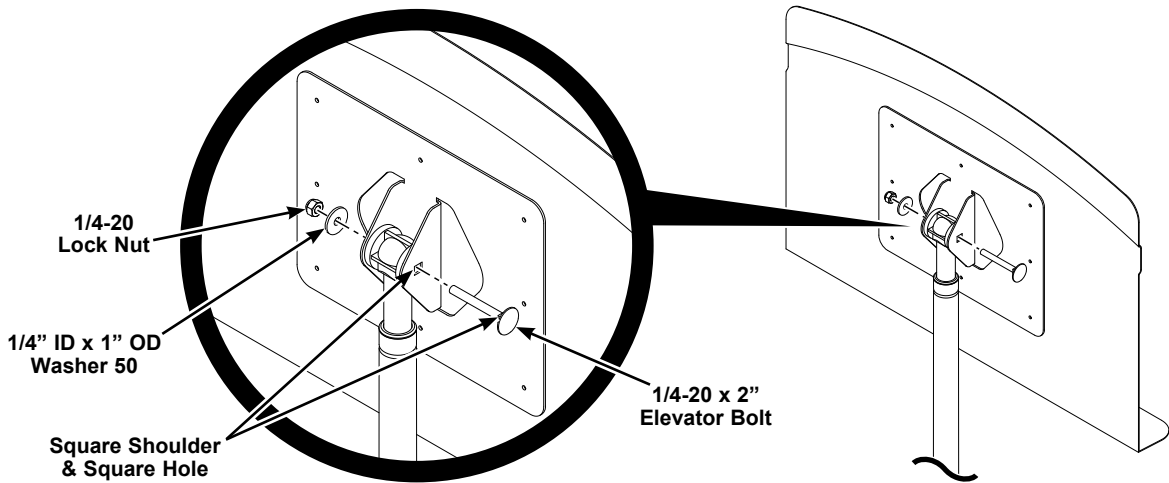

**Note:** If assembling a Preface Conductor's Stand, follow these steps for both Slider Assemblies.

- Fully extend the Slider Assembly.

The inner surface of the outer tube is lubricated with a high pressure grease to extend the life of the Music Stand and to prevent corrosion during shipping and storage.

Wipe off any excess grease from the inner tube with a rag or paper towel as needed.

This should only be necessary the first time the Slider Assembly is fully extended.

## **Operation**

---

Use the Music Stand with care.

1. Move the Inner Tube of the Slider Assembly up or down to adjust the height of the Desk.
2. Pivot the Desk to the required angle.

**Note:** The tension for the desk angle can be tightened by adjusting the Nut on the Elevator Bolt.

***Be sure that the square shoulder of the Elevator Bolt slips into the square hole of the Desk Flange or the Desk will not tighten properly.***

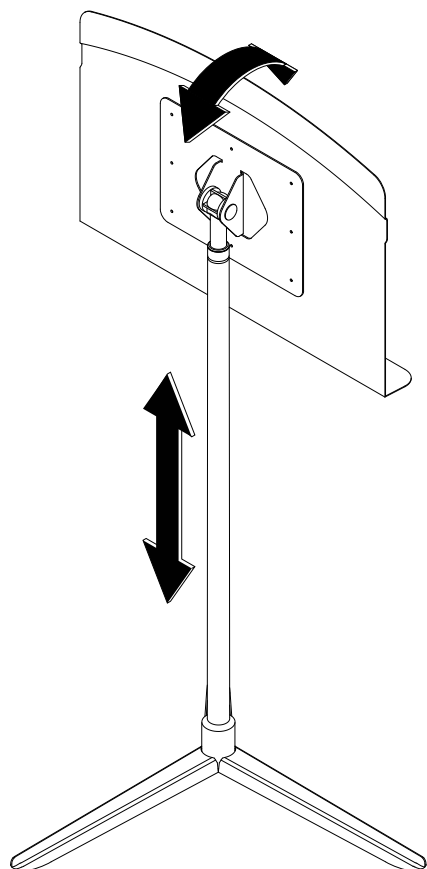

## **Storage**

---

Storage of the Music Stands is available by using the following accessories:

### ***Large Stand Move and Store Cart***

- 38 lbs (17 kg)
- Holds 18 Bravo Stands
- Holds 20 Roughneck Stands
- Holds 20 Classic 50 Stands
- Holds 20 Preface Stands without flipping desk  
Maximize cart storage to hold 22 Preface Stands by flipping desk
- Large center pivot wheels for maneuverability
- Loads and unloads from both ends

### ***Small Stand Move and Store Cart***

- 21 lbs (9.45 kg)
- Holds 9 Bravo Stands
- Holds 10 Roughneck Stands
- Holds 10 Classic 50 Stands
- Holds 10 Preface Stands without flipping desk  
Maximize cart storage to hold 11 Preface Stands by flipping desk
- Two-wheel cart design allows transport up and down stairs

## **Maintenance**

---

1. Clean the music stand with a mild detergent.  
Avoid using harsh or abrasive cleaning products.
2. Never apply oil or any lubricant to the Slider Assembly.
3. Periodically check fasteners to ensure that they have not loosened during use.