

Nota® Premier Chair

- 0320000 Black finish frame, 12 lbs (5.4 kg).
- 0320001 Chrome finish frame, 12 lbs (5.4 kg).
- Black powder-coat paint finish frame for maximum durability. Chrome finish frame is also available.
- Patented design provides two seating zones: "Engaged" (rear) and "Perched" (forward).
 - The engaged position allows the occupant to sit with a thigh to back angle of 97°.
 - The perched position allows the occupant to sit with a thigh to back angle in the range of 96-106°.
 - A transition area allows users to move seamlessly between zones.
 Each zone enhances performance by promoting a naturally balanced skeletal shape, reducing muscle strain and enabling increased circulation, freedom of movement, and diaphragmatic breathing.
- Narrow convex back provides lumbar support while still allowing for freedom and range of movement.
- Seat and back are rugged polypropylene with 1/2" (13 mm) polyfoam seat cushioning and 1/4" (6 mm) polyfoam back cushioning.
- Seat and back are covered with 100% polypropylene fabric and available in six colors: Black, Plum, Red, Green, Grey and Blue.
- Fabric is treated with BLOCKaide™ Stain Repellant.
- 14-gauge 7/8" (22 mm) welded round tube frame.
- Available in heights of 14-1/2" (368 mm), 16" (406 mm), 17-1/2" (445 mm), 19" (483 mm), 20-1/2" (521 mm).
- Rounded waterfall front allows one height of chair to accommodate a wider range of body sizes.
- Durable, specially designed floor glides provide stability when seated and ease of movement when arranging chairs.
- Chairs stack for compact storage, up to twelve chairs on a cart; six without a cart. If chairs are equipped with the Ganging Clamp Accessory, they can be stacked no more than five high.
- Specially designed stacking bumpers provide maximum stability and protection when chairs are stacked.
- ANSI/BIFMA x 5.1-2002
- California Technical Bulletin 117 compliant.
- UL GREENGUARD Certified - Product certified for low chemical emissions: ul.com/gg - UL 2818.
- Environmental attributes and LEED compliance for these products can be found at www.wengercorp.com/GREEN or by contacting your Wenger representative.
- Five-year warranty.

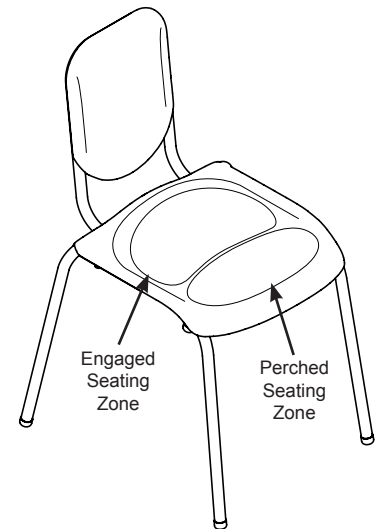
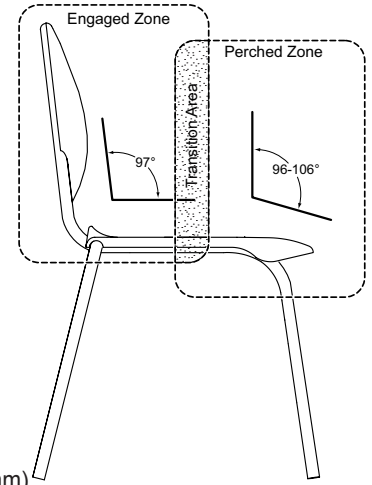

Chair Height	A*	B	C	D
14-1/2" (368 mm)	14-1/2" (368 mm)	19" (483 mm)	19-3/8" (492 mm)	29-1/8" (752 mm)
16" (406 mm)	16" (406 mm)	19" (483 mm)	20-1/8" (511 mm)	30-3/4" (781 mm)
17-1/2" (445 mm)	17-1/2" (445 mm)	19" (483 mm)	21" (533 mm)	32-1/4" (819 mm)
19" (483 mm)	19" (483 mm)	19" (483 mm)	21-5/8" (549 mm)	33-7/8" (860 mm)
20-1/2" (521 mm)	20-1/2" (521 mm)	19" (483 mm)	22-1/4" (565 mm)	35-3/8" (899 mm)

*Dimension "A" measures frame height, not seat height.

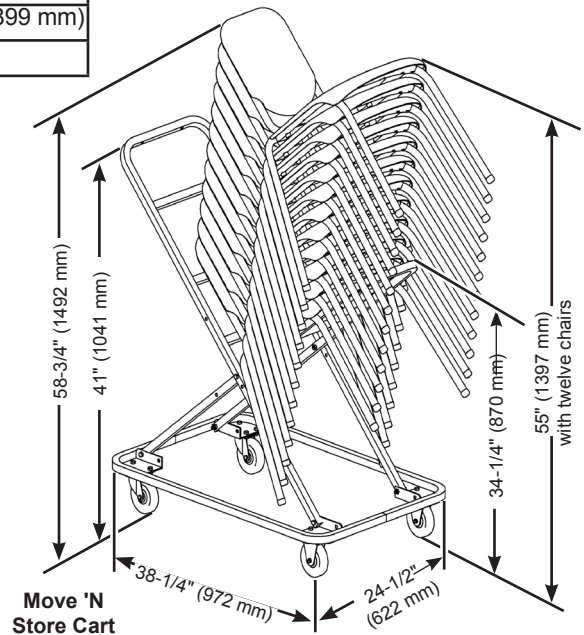
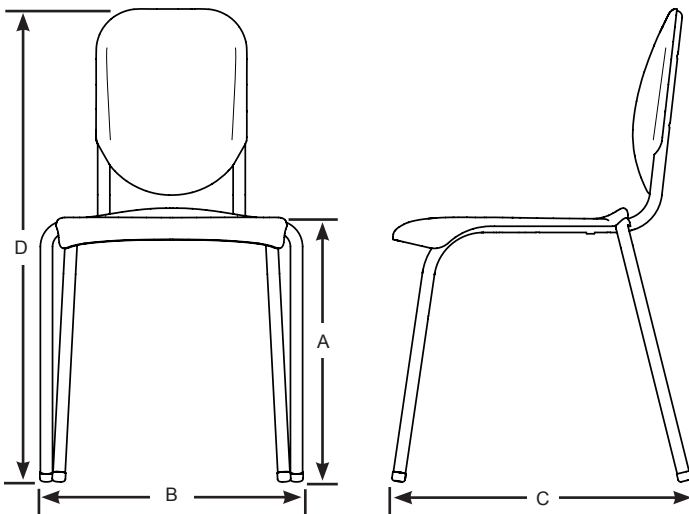

Accessories Include:

Move 'N Store Cart

- 127A261 30 lbs (13.6 kg).
- Stack, move and store up to 12 Nota Premier Chairs.
- 16-gauge steel construction with easy roll casters.

Universal Folding Tablet Arm

- 0331010 5 lbs (2.3 kg).
- Can be set up for either right or left hand configuration.
- Choice of laminated surface colors: Graphite, Cherry, Fusion Maple and Solar Oak.
- 14" x 11-1/2" (356 x 292 mm) desk surface.
- Black polycarbonate desk tray.
- 14-gauge support assembly.
- Can be added at any time.
- Chairs cannot be stacked with this accessory attached.

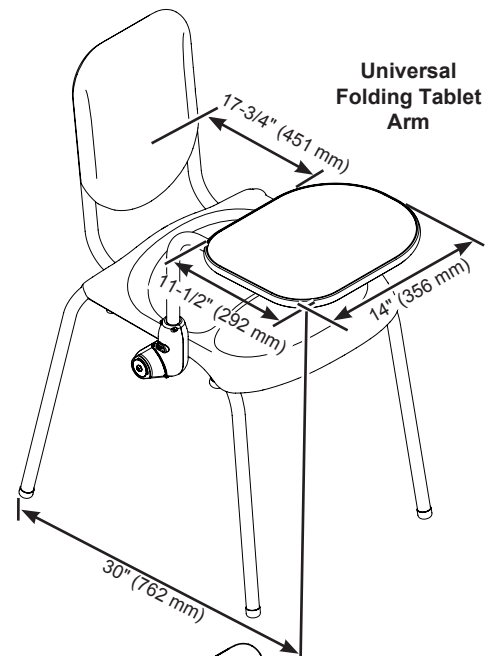

Book & Music Storage Rack

- 190A066 2 lbs (1 kg).
- Mounts under chair.
- Black powder-coat paint finish for maximum durability.
- 3/16" diameter solid steel rod construction.
- Can be added at any time.
- Maximum storage weight: 30 lbs.
- Chairs cannot be stacked with this accessory attached.



Tuba Rest

- 190A187 3 lbs (1.4 kg).
- Thru-bolted frame 16-gauge steel construction supports the full weight of the tuba.
- Height and depth adjustable.
- Vinyl protective coating.
- Can be added at any time.
- Chairs cannot be stacked with this accessory attached.

Sousaphone Holder

- 190A184 11 lbs (5 kg).
- 14-gauge steel support frame and 16-gauge steel uprights.
- Supports and helps balance the sousaphone.
- Can be used for storage.
- Adjustable height.
- Vinyl protective coating.
- Can be added at any time.
- Chairs cannot be stacked with this accessory attached.

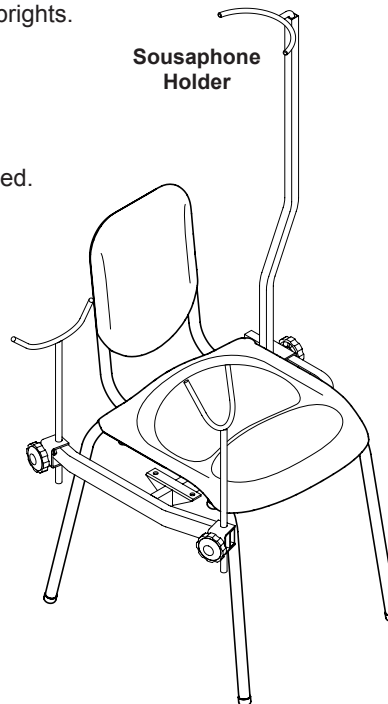

Ganging Clamps

- 190A059.
- Molded polycarbonate.
- Used to connect chairs together.

Dust Cover

- 054D500.
- Vinyl coated polypropylene.
- For use with chairs stacked on cart.

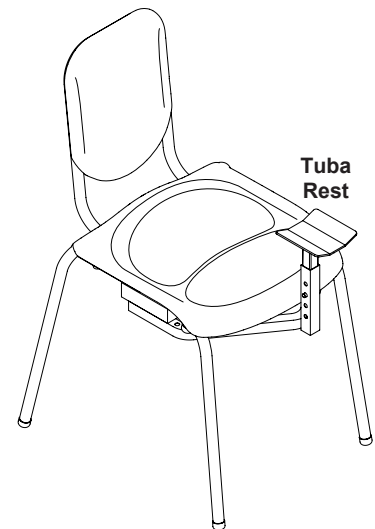

Wenger

JRCLANCY

GEARBOSS

© 2017 Wenger Corporation
USA/2017-12/W



WENGER CORPORATION

Phone 800.4WENGER (493-6437) Worldwide +1.507.455.4100 | Fax 507.455.4258 Worldwide +1.507.774.8576
Parts & Service 800.887.7145 | Canada Office 800.268.0148 | Web wengercorp.com | 555 Park Drive, PO Box 448 | Owatonna | MN 55060-0448

JR CLANCY

Phone 800.836.1885 Worldwide +1.315.451.3440 | Fax 877.836.1885 Worldwide +1.315.451.1766 | Web jrclancy.com
7041 Interstate Island Road | Syracuse | NY 13209-9713

GEARBOSS

Phone 800.493.6437 | email gearboss@wengercorp.com | Web gearboss.com | 555 Park Drive, PO Box 448 | Owatonna | MN 55060-0448