

CONTENTS

Important User Information	2
Safety	3
Tools Required	4
Fastener List	4
Parts List	4
Assembly	5
Operation	8
Maintenance	8

Note: Please read and understand these instructions before assembly or use.

Note: Remove all items from the shipping cartons and arrange them in a convenient location. Refer to the illustrations on the following pages. If you need additional information, contact the Wenger Corporation using the information below.

IMPORTANT USER INFORMATION

GENERAL

Copyright © 2015 by Wenger Corporation

All rights reserved. No part of the contents of this manual may be reproduced, copied, or transmitted in any form or by any means including graphic, electronic, or mechanical methods or photocopying, recording, or information storage and retrieval systems without the written permission of the publisher, unless it is for the purchaser's personal use.

Printed and bound in the United States of America.

The information in this manual is subject to change without notice and does not represent a commitment on the part of Wenger Corporation. Wenger Corporation does not assume any responsibility for any errors that may appear in this manual.

In no event will Wenger Corporation be liable for technical or editorial omissions made herein, nor for direct, indirect, special, incidental, or consequential damages resulting from the use or defect of this manual.

The information in this document is not intended to cover all possible conditions and situations that might occur. The end user must exercise caution and common sense when assembling or installing Wenger Corporation products. If any questions or problems arise, call Wenger Corporation at 1-800-733-0393.

MANUFACTURER

The OnBoard® Bass Drum/Gong Cart is manufactured by:
Wenger Corporation
555 Park Drive
Owatonna, MN 55060
1-507-455-4100 • 1-800-733-0393
www.wengercorp.com

INTENDED USE

- This product is intended for indoor use in normal ambient temperature and humidity conditions and limited outdoor use — it must not be exposed to prolonged outside weather conditions.
- This product is intended to be assembled only as described in these instructions.

WARRANTY

This product is guaranteed free of defects in materials and workmanship for five full years from date of shipment. A full warranty statement is available upon request.

SAFETY PRECAUTIONS

Throughout this manual you will find **CAUTIONS** and **WARNINGS** which are defined as follows:

- **WARNING**; failure to follow the instruction may result in serious injury or death.
- **CAUTION**; failure to follow the instruction may result in serious injury or damage to property.

! CAUTION
Do not transport people or stand on the Bass Drum/Gong Cart.

! CAUTION
When towing the Bass Drum/Gong Cart do not exceed 5 mph or tow more than three carts together.

! CAUTION
When towing the Bass Drum/Gong Cart, avoid tight turns which may result in the tow vehicle making contact with the cart or tow bar.

Note: Failure to comply with precautions in this section can result in serious injury.

ASSEMBLY

- Ensure anyone who helps assemble the Bass Drum/Gong Cart has read and understands this manual.

OPERATION

- Bass Drum/Gong Cart maximum total load capacity is 55 lbs.
- The Bass Drum/Gong cart is only intended to hold either a Bass Drum or Gong.
- When moving the cart to and from performing areas the pivot loop assembly must be locked in the upright position and the speed is not to exceed 5 mph.
- When the Bass Drum/Gong Cart is left unattended, it must be placed in a secure position so that it does not move or roll into vehicles, structures or people.
- All four casters must be in contact with the floor or ground at all times.
- Avoid ramps steeper than a one-foot rise or drop in a 12-foot horizontal distance.
- Because swivel casters move in any direction, the operator must move the cart slowly and have a clear view to avoid obstructions and individuals standing in the direction of travel.
- When transporting the Bass Drum/Gong Cart in a vehicle it must be braced with tie-downs, chains or cargo straps designed specifically for that purpose so cart will not move.
- Blankets or other padding material may be required to avoid damage to the cart and accessories from vibration and impact during transport.
- When moving the cart, do not ride and do not allow others to ride on the cart.
- Use caution when attaching either a Bass Drum or Gong on the cart.
- When towing the Bass Drum/Gong Cart, avoid tight turns which may result in the tow vehicle making contact with cart or tow bar. Injury or damage may result.
- Never move or position the Bass Drum/Gong Cart sideways on an incline.

TOOLS REQUIRED

- 9/16" Wrench or 9/16" Socket with Ratchet
- 3/8" Wrench
- Small Phillips Screwdriver
- 3/16" Allen Wrench (provided)
- 5 mm Hex Wrench (provided)



FASTENER LIST

Note: Extra hardware can be discarded.

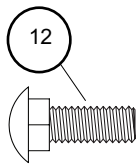

Carriage Bolt,
3/8"-16 x 1

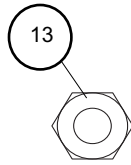

Lock Nut,
3/8"

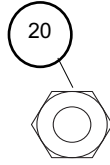

Thin Lock Nut,
3/8"

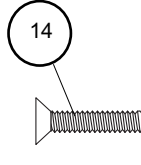

Machine Screw
#10-24 x 5/8"



Nylon Lock Nut
#10- 24

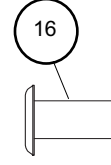

Joint Connector
Nut

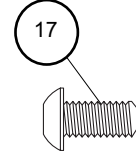

Socket Screw
5/16"-18 x 1

PARTS LIST

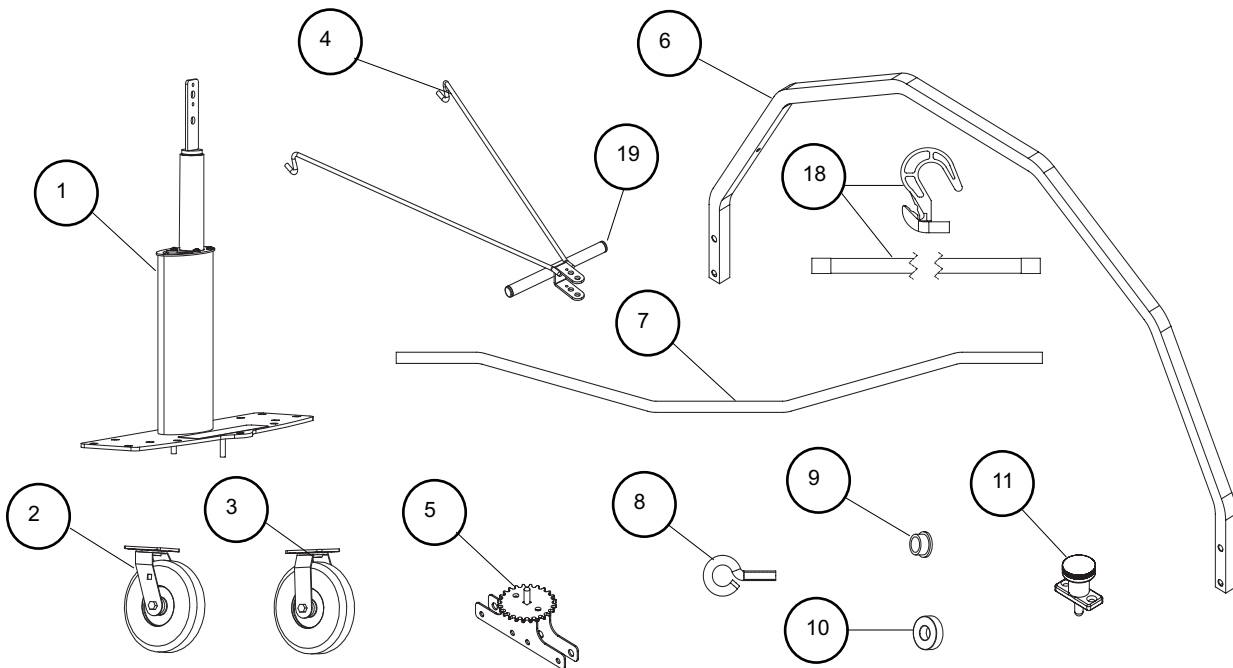

Item # Description

- 1 BASE ASSEMBLY
- 2 SWIVEL CASTER
- 3 RIGID CASTER
- 4 TOW BAR
- 5 ADJUSTABLE PIVOT WELDMENT
- 6 DRUM/GONG TUBE LOOP

Item # Description

- 7 CROSS MEMBER
- 8 EYE BOLT, 1/4 X 20
- 9 FLANGE BEARING, 3/8 X 1/2
- 10 SPACER BEARING, 3/8
- 11 LOCKING PULL PIN
- 18 BUNGEE CORD KIT
- 19 TUBE PLUG

ASSEMBLY

Assemble casters (#2 and #3) to the base assembly (#1).

1. Align the swivel casters (#2) with the bolt holes on the base assembly (#1).
2. Attach the casters to the base assembly using 3/8" carriage bolt (#12) and lock nut (#13). **(Detail A)**

Note: The same caster type (swivel or rigid) must be assembled to each base assemblies.

3. Align the rigid casters (#3) with the bolt holes on the remaining base assembly (#1).
4. Repeat step 2.

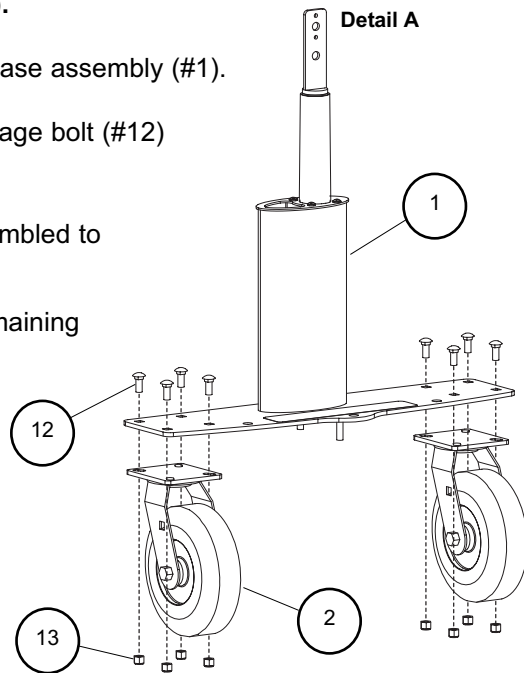

Assemble the cross member (#7) to the base assemblies (#1).

5. Lay the base assemblies on end.
6. Align the cross member (#7) to the bolts located on the bottom of the base assemblies. **(Detail B)**
7. Secure the cross member to the base assemblies using 3/8" lock nuts (#13).

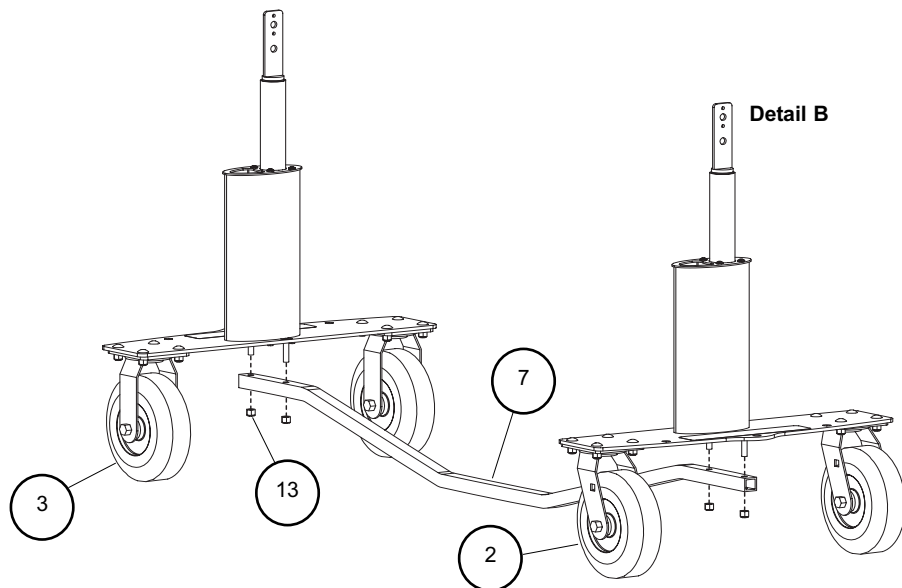

ASSEMBLY (CONTINUE)

8. Position the cart upright on the casters.
9. Using machine screws, #10-24 x 5/8" (#14) and nylon lock nut #10-24 (#15) loosely attach the locking pull-pin (#11) to the top extrusion of the base assembly (#1). Do not tighten the screws and lock nuts. **(Detail C)**
10. Repeat step 9 for the other end of the cart.

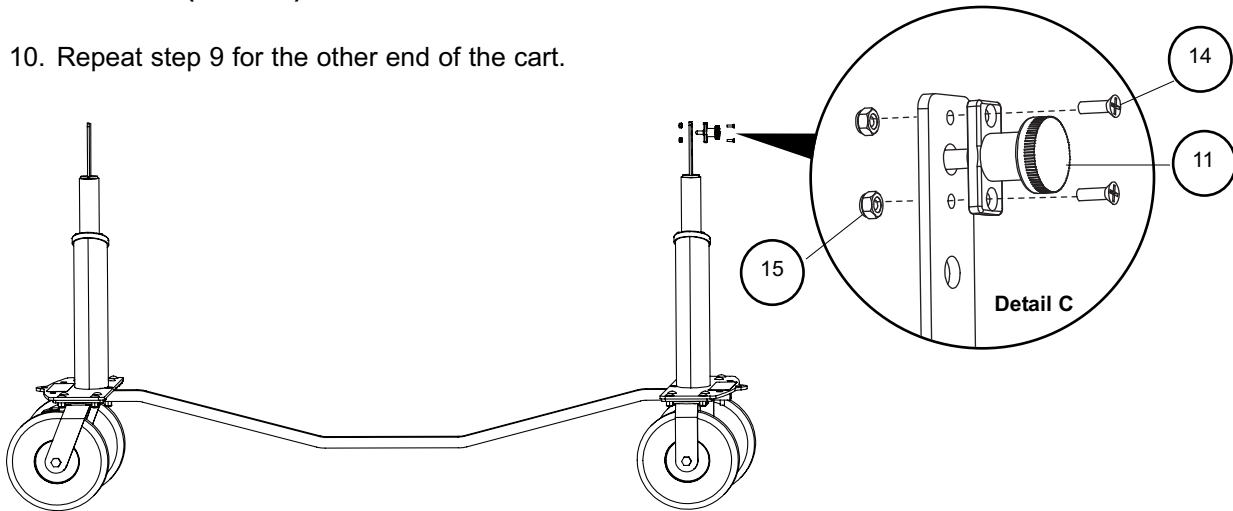

Assemble the drum/gong tube loop (#6). **(Detail D)**

11. Lay the two halves of the drum/gong tube loop (#6) on a flat surface aligning them to make one large loop.
12. Connect the drum/gong loop halves (#6) using the adjustable pivot weldment (#5).
 - Slide both end of the drum/gong loop halves between the brackets of the adjustable pivot weldment. The sprocket to the outside of the loop.

Note: The adjustable pivot weldment has two different sizes of holes. Make sure when assembling them to the loop halves that the large holes face up on both parts.

 - Align the bolt holes of the drum/gong loop and adjustable pivot weldment.
 - Secure using socket screws, 5/16"-18 x 1 (#17) and joint connector nut (#16).
 - Tighten the socket screws (#17) and joint connector nut (#16) with the wrenches provided in the hardware pack.
13. Screw the eye bolts (#8) into the drum/gong loop. There are a total of 10 eye bolts.

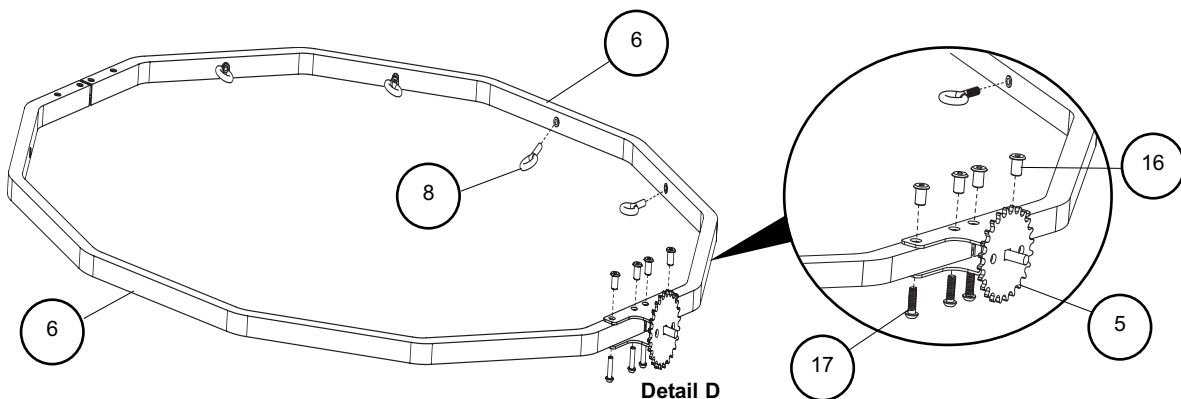

ASSEMBLY (CONTINUE)

Assembling the drum/gong loop onto the cart.

14. Slide spacer bearing (#10) onto the bolt of the adjustable pivot weldment (#5). **(Detail E)**
15. Slide flange bearing (#9) onto the bolt on the adjustable pivot weldment (#5) with the flange side in, next to the spacer bearing (#10). **(Detail E)**
16. Repeat on the other side of the drum/gong loop.

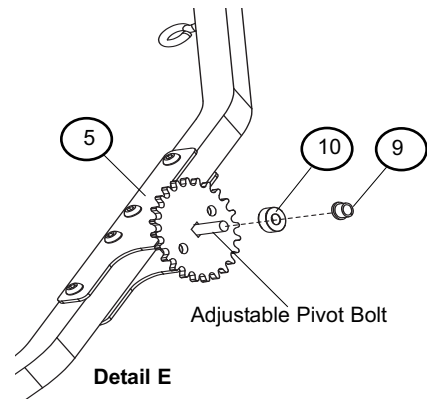

CAUTION

The next steps require two people to complete.

17. Lift the drum/gong loop assembly onto the cart aligning the bolt on the adjustable pivot weldment (#5) with the bolt hole in the top of the cart base assembly (#1). **(Detail F)**
18. Once you have one side of the drum/gong loop assembly aligned into the base assembly, pull back gently on the opposite base assembly towards the top to align the bolt on the adjustable pivot weldment (#5) with the bolt hole in the top of the base assembly.
19. Secure the drum/gong loop assembly to the cart using lock nuts (#20).
20. Tighten the screws (#14) and lock nuts (#15) to secure the locking pull-pin (#11). Refer to step 9.

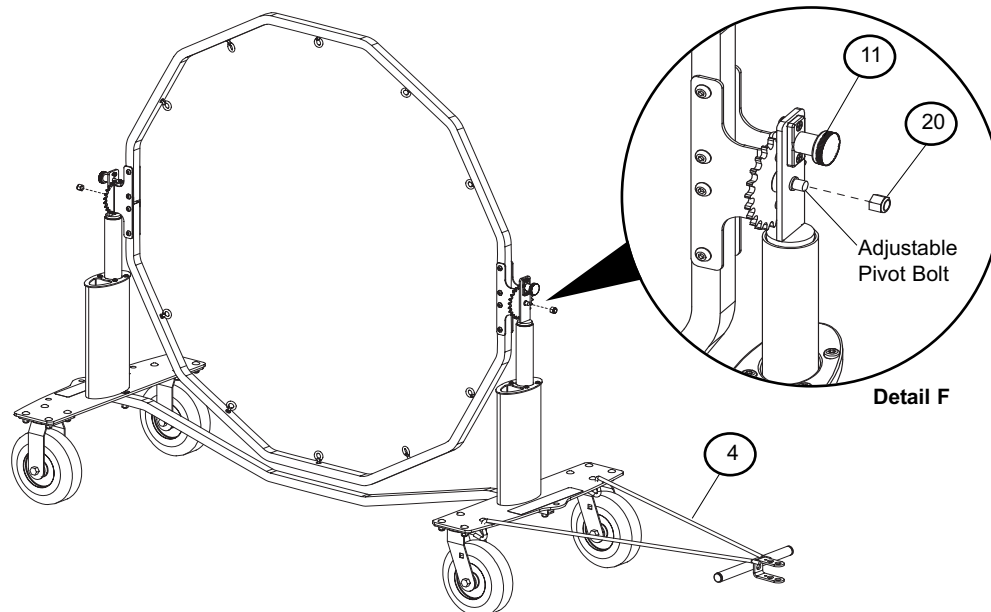

21. A separate tow bar (#4) is provided which inserts into two holes in the Bass Drum/Gong Cart base assembly (#1). The tow bar may be used as a handle to pull the Bass Drum/Gong Cart manually or can be attached horizontally to a lawn and garden tractor.

OPERATION

To mount the bass drum onto the OnBoard Bass Drum/Gong Cart;

1. Attach the hook to one end of the bungee cord.
 - Make a loop at the end of the bungee cord.
 - Push the loop through the bottom of the hook bringing it up in front of the hook. **(Detail G)**
 - Wrap the loop around to the back of the hook. **(Detail H)**
 - Pull tightly to secure the loop

CAUTION

The next steps require two people to complete.

2. With one person holding the bass drum, starting at the center of the bottom tube loop, weave the bungee cord (end without hook) through the bass drum and eye hooks on the cart.
3. Tighten the tension of the bungee cord as you go, keeping the bass drum centered on the cart.
4. At the bottom of the cart, with the bungee cord taunt and the bass drum centered, attached the remaining hook to the end of the cord. Refer to step 1.
5. Secure the bass drum by hooking the two hooks together and tighten if necessary.

Note:

- Bass drums vary in size, some variations may be required.
- Extra hardware can be discarded.

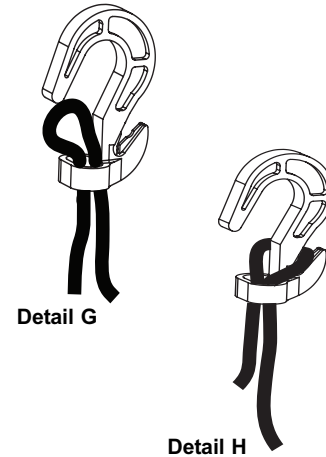

MAINTENANCE

- Clean the Bass Drum/Gong Cart with a mild detergent and warm water. Avoid using harsh or abrasive cleaning products.
- Inspect tire pressure periodically as tires may lose air pressure when not used for long periods of time.
- Immediately replace any Caster wheels that do not rotate or turn freely.
- Immediately replace or repair any tire that develops a flat area.
- Recommended tire pressure is 50 psi. Do not exceed the maximum tire pressure shown on the sidewall of the tire.
- During heavy usage, periodically check and tighten the fasteners.
- Grease zerks and bushings if required.