

# OnBoard® Uniform Cart

- 210A007 OnBoard Uniform Cart, 56 lbs. (25 kg).
- Ideal for transporting marching band uniforms in the storage compartments of a coach bus.
- Designed to fit into trailers, semi-trailers and trucks.
- Equipped with two 16-gauge, 1-1/4" (32 mm) round steel tubing with steel end plates for labeling.
- Frame is constructed of 14-gauge 1-1/4" (32 mm) round tubular steel in black powder-coat paint finish.
- Back and bottom tray constructed of black ABS plastic for superior strength and durability.
- Fits through standard 32" (813 mm) door.
- Includes built-in handholds for tilting and sliding cart into storage compartment - no lifting involved.
- Glides included on back of cart for sliding into compartment.
- Capacity for twenty-four marching band uniforms.
- 28 hanger retainer clips included with cart.
- All-swivel, non-marring solid polypropylene 4" dia. (102 mm) casters provide easy maneuverability.
- Dimensions: 48" (1219 mm) long x 23" (584 mm) deep x 45-1/2" (1156 mm) high.
- UL GREENGUARD Certified - Product certified for low chemical emissions: [ul.com/gg](http://ul.com/gg) - UL 2818.
- Environmental attributes and LEED compliance for this product can be found at [www.wengercorp.com/GREEN](http://www.wengercorp.com/GREEN) or by contacting your Wenger representative.
- Five-year warranty.
- Shipped fully assembled.

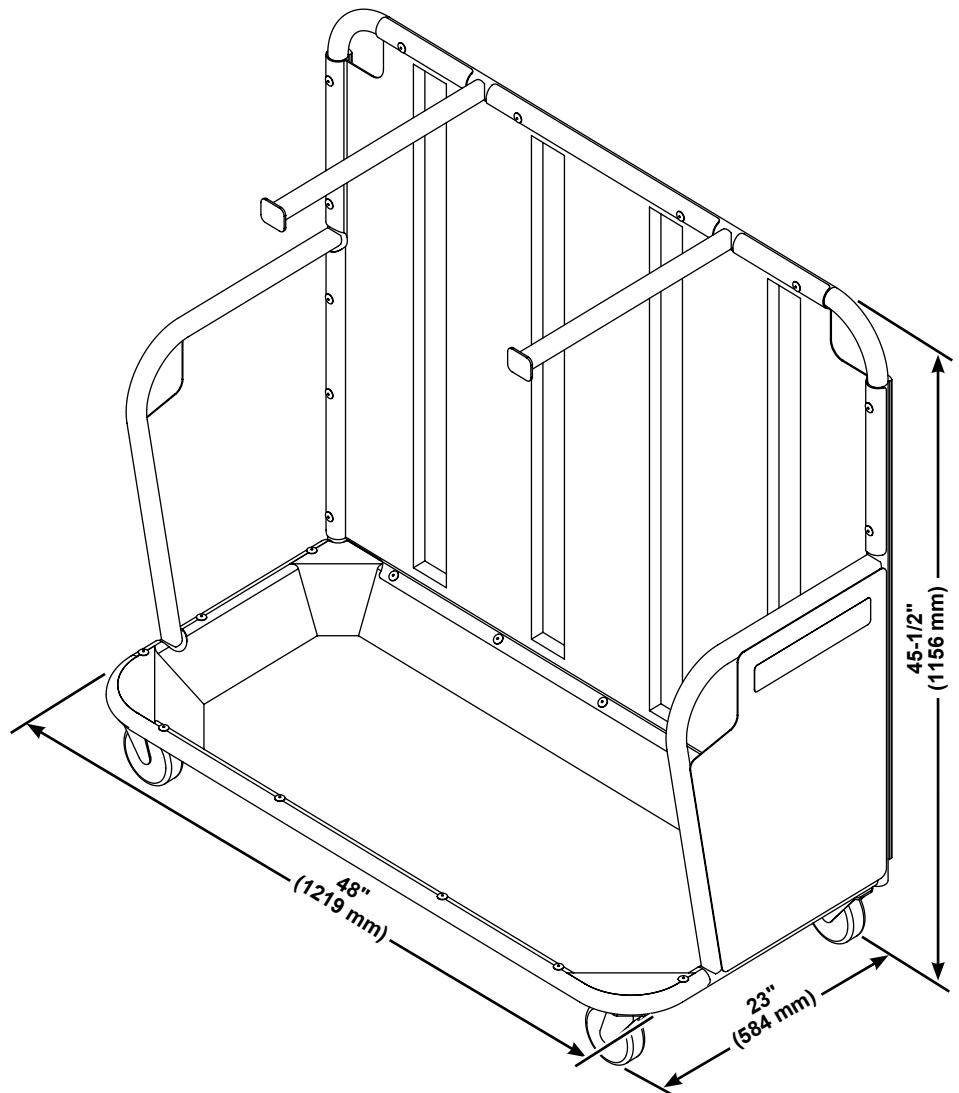

© 2018 Wenger Corporation  
USA/2018-12/W



## WENGER CORPORATION

Phone 800.4WENGER (493-6437) Worldwide +1.507.455.4100 | Parts & Service 800.887.7145 | Canada Office 800.268.0148 | [wengercorp.com](http://wengercorp.com)  
555 Park Drive, PO Box 448 | Owatonna MN 55060-0448

## JR CLANCY

Phone 800.836.1885 Worldwide +1.315.451.3440 | [jrclancy.com](http://jrclancy.com) | 7041 Interstate Island Road | Syracuse NY 13209-9713

## GEARBOSS

Phone 800.493.6437 | email [gearboss@wengercorp.com](mailto:gearboss@wengercorp.com) | [gearboss.com](http://gearboss.com) | 555 Park Drive, PO Box 448 | Owatonna MN 55060-0448